

GWM TANK

Owner's Manual



Owner's Manual

GWM TANK 300

GWM TANK

Thank you for choosing the Great Wall Motors vehicle.

The more familiar you become with your vehicle, the more you will like it and the better you will be able to use its features. Therefore, you are kindly required to: Read this manual carefully before using your vehicle. There are important tips about using your vehicle in this manual that will help you make the best use of your vehicle's technology. Additionally, you will get very useful information about driving safety, road safety and maintenance of your vehicle value.

We sincerely wish you a safe and happy journey!

11/06/2024

Overview

Contain instructions for use, explanation of symbol meanings, etc.

Vehicle statement

This vehicle is a multi-purpose model. It not only has the comfort of an urban SUV, but also has a certain degree of trafficability and extrication ability for the models equipped with all-terrain control system, differential lock and other equipment to meet the needs of users in a variety of scenarios.

For off-road driving, be sure to perform a series of all-terrain exercises on a fully licensed professional venue. All-terrain driving requires sufficient training and rich experience, or the installation of other configurations. Otherwise, there will be risks of personal injury and destruction of vehicles and articles. Please drive with caution. Before off-road driving, be sure to carefully survey the route and road conditions.

The driver should use all on-board functions under the premise of ensuring safety.

Vehicle equipment

Please note that this manual contains all the standard equipment, country-specific equipment and special equipment for this model series. Thus, some equipment or features described in this manual may not be installed onto your vehicle or are only available in some markets. For specific configuration information, please refer to relevant sales materials or consult your vehicle dealer.

In a right-hand drive vehicle, the actual position of some operating elements may be different from that shown in the illustration.

Accessories, spare parts and modifications

Now we can buy not only genuine parts, but also a variety of other non-genuine parts and accessories that are suitable for our vehicle. The use of non-authentic spare parts and accessories may adversely affect vehicle safety, even if these products have been approved by the relevant national or regional authorities. Great Wall Motors do not afford any responsibility and do not offer any warranty certificate if the owner decides to install or replace non-authentic spare parts and accessories.

It is forbidden to modify vehicles with non-authentic products. Modifications with non-authentic products may affect vehicle operability, safety or durability and may even violate government regulations. In addition, vehicle damage and performance issues arising from modification are not covered by warranty of quality.

It is forbidden to modify suspension, braking system and so on, which may adversely affect the operate safety of vehicle.

It is forbidden to modify the fuse box of the vehicle. Otherwise, the electrical system may be adversely affected.

Modification to electronic components, software and circuits will affect their function and the normal operation of other related components, especially safety-related systems. These modifications will affect the operation safety of the vehicle and increase the risk of accidents and injury. Therefore, please do not modify pipeline, electrical parts and software.

Validity of this manual

All information provided in this manual is up to date at the time of publication. However, due to continuous improvement of the product, the contents of this manual will be updated at any time without notice.

Depending on the vehicle specifications, vehicles shown in the figure may differ from your vehicle.

The display information (including pictures, icons, texts and so on) included in this manual are only for instructions. According to the vehicle model configuration, software version and theme settings, the actual information displayed may be different. Refer to the actual model for specific information.

About symbols

WARNING

This indicates a warning.

Failure to observe these warnings may result in serious injury or death. Such warnings tell you what to do or what not to do so as to reduce the risk of serious injuries or death.

CAUTION

This indicates a caution.

Failure to observe these cautions may result in damage to the vehicle or its equipment. Such cautions tell you what to do or what not to do so as to avoid or reduce the risk of damage to the vehicle and its equipment.

NOTICE

This indicates a reminder.

Such tips contain helpful information that may be of use to you.

(▷ Page X)

This symbol indicates that more details can be seen on this page.

Tips for safety

⚠ WARNING

General precautions for your driving:

- ▷ Drive only when fully alert: the alcohol, drug, medicine or anesthetic will slow down driver's response time and affect judgment and coordination, which makes the vehicle get out of control and results in severe safety accidents.
- ▷ Drive carefully: be sure to drive carefully. Always keep an eye on improper movements of other drivers or pedestrians on the road so as to make timely judgments and prevent accidents.
- ▷ Concentrate on driving: be attentive when driving. Anything that distracts the driver's attention, such as adjusting control buttons, call up and answer a mobile phone or reading, may give rise to a crash accident and serious injury to you, passengers on the vehicle and other people.

⚠ WARNING

When getting out of the vehicle, do not leave children, pets or someone who needs help in the vehicle alone.

- ▷ Because the children, pets or someone who needs help cannot get out of the vehicle and save themselves. The temperature in the vehicle may be too high or too low in different weather, which may cause the passengers or pets in the vehicle injury even death.
- ▷ If the children or pets touch the key, the vehicle may move itself which is dangerous for yourselves and the vehicle, including starting the vehicle, releasing the parking brake, shifting gears, operating the doors and windows.

Appearance (Type I)

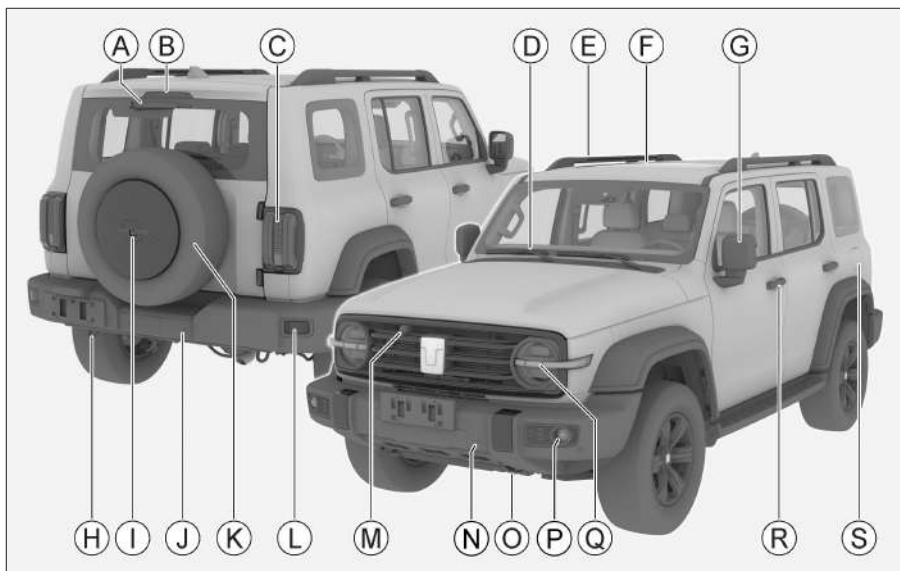

FB9EFBB4C9F3

- | | |
|---------------------------------|---------------------------------|
| Ⓐ Rear wiper 60 | Ⓚ Spare tyre 234 |
| Ⓑ High-mounted brake light | Ⓛ Rear fog light 51 |
| Ⓒ Rear combination light 51 | Ⓜ Around View Monitor (AVM) 131 |
| Ⓓ Front wiper 58 | Ⓝ Anti-collision radar 130 |
| Ⓔ Roof rack 49 | Ⓞ Front tow hook 247 |
| Ⓕ Sunroof 34 | Ⓟ Front fog light 51 |
| Ⓖ Mirror 45 | Ⓠ Front combination light 51 |
| Ⓗ Rear tow hook 247 | Ⓡ Door handle 24 |
| Ⓘ Around View Monitor (AVM) 131 | Ⓢ Fuel tank door 38 |
| Ⓝ Anti-collision radar 130 | |

Appearance (Type II)

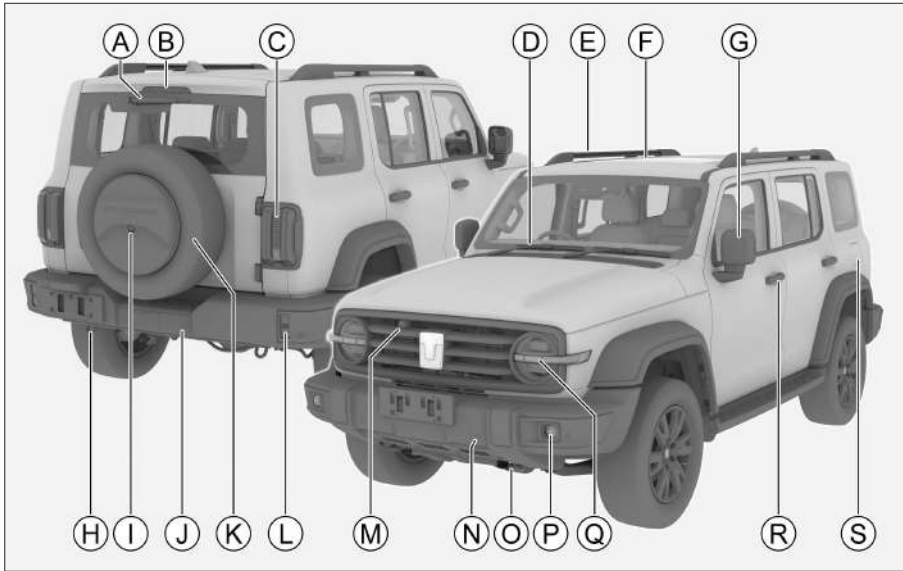

- Ⓐ Rear wiper 60
- Ⓑ High-mounted brake light
- Ⓒ Rear combination light 51
- Ⓓ Front wiper 58
- Ⓔ Roof rack 49
- Ⓕ Sunroof 34
- Ⓖ Mirror 45
- Ⓗ Rear tow hook 247
- Ⓘ Around View Monitor (AVM) 131
- Ⓝ Anti-collision radar 130
- Ⓚ Spare tyre 234
- Ⓛ Rear fog light 51
- Ⓜ Around View Monitor (AVM) 131
- Ⓝ Anti-collision radar 130
- Ⓞ Front tow hook 247
- Ⓟ Front fog light 61
- Ⓠ Front combination light 51
- Ⓡ Door handle 24
- Ⓢ Fuel tank door 38

Interior trim - Left-hand drive models

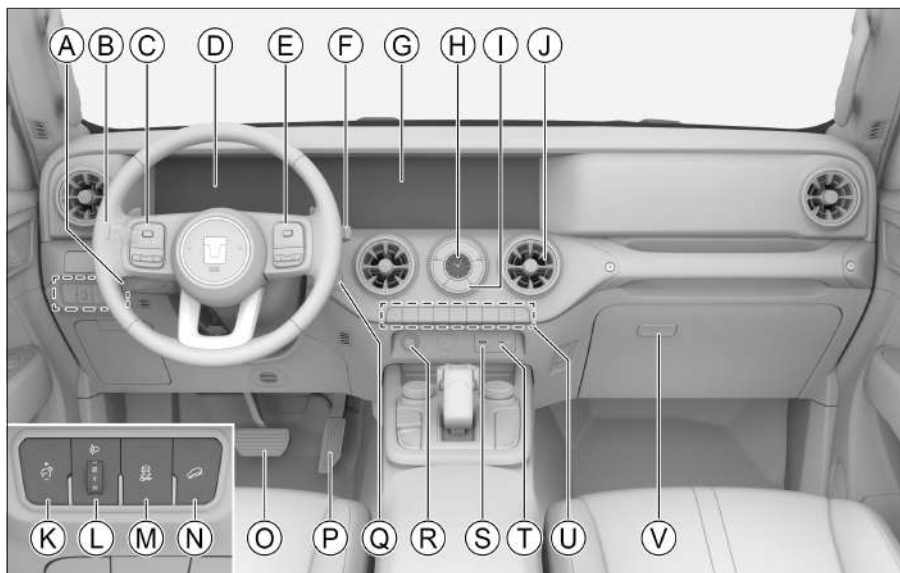

- Ⓐ Cruise control assist system lever 140
- Ⓑ Light control combination switch 51
- Ⓒ Audiovisual system button 196
- Ⓓ Virtual instrument panel 177
Instrument indicator lights 182
- Ⓔ Instrument panel adjustment button 179
- Ⓕ Wiper control combination switch 58
- Ⓖ Audiovisual system display 197
- Ⓗ Electronic clock
- Ⓘ Hazard warning light button 56
- Ⓝ A/C outlet 68
- Ⓚ Instrument panel brightness adjustment button 56
- Ⓛ Light height adjustment knob 56
- Ⓜ Electronic stability control switch 171
- Ⓝ Hill descent control system switch 168
- Ⓞ Brake pedal
- Ⓟ Accelerator pedal
- Ⓠ Power supply switch 101
- Ⓡ Standby power supply interface 79
- Ⓢ USB interface 197
- Ⓣ USB-Type-C power supply interface 79
- Ⓤ A/C system buttons 62
- Ⓥ Storage box 72

Interior trim - Right-hand drive models

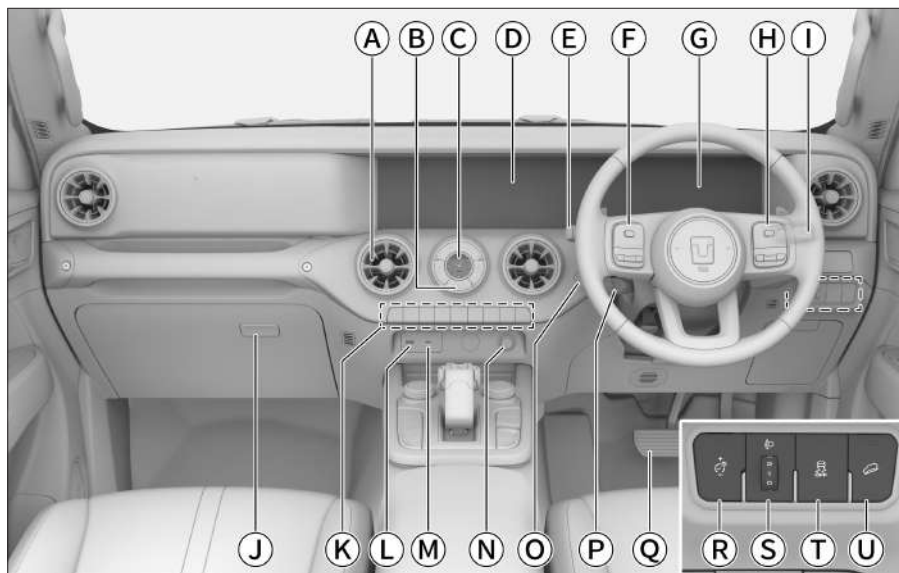

- A A/C outlet 68
- B Hazard warning light button 56
- C Electronic clock
- D Audiovisual system display 197
- E Light control combination switch 51
- F Audiovisual system button 196
- G Virtual instrument panel 177
Instrument indicator lights 182
- H Instrument panel adjustment button 179
- I Wiper control combination switch 58
- J Storage box 72
- K A/C system buttons 62
- L USB interface 197
- M USB-Type-C power supply interface 79
- N Standby power supply interface 79
- O Power supply switch 101
- P Cruise control assist system lever 140
- Q Brake pedal
- R Instrument panel brightness adjustment button 56
- S Light height adjustment knob 56
- T Electronic stability control switch 171
- U Hill descent control system switch 168

Auxiliary instrument panel - Left-hand drive models

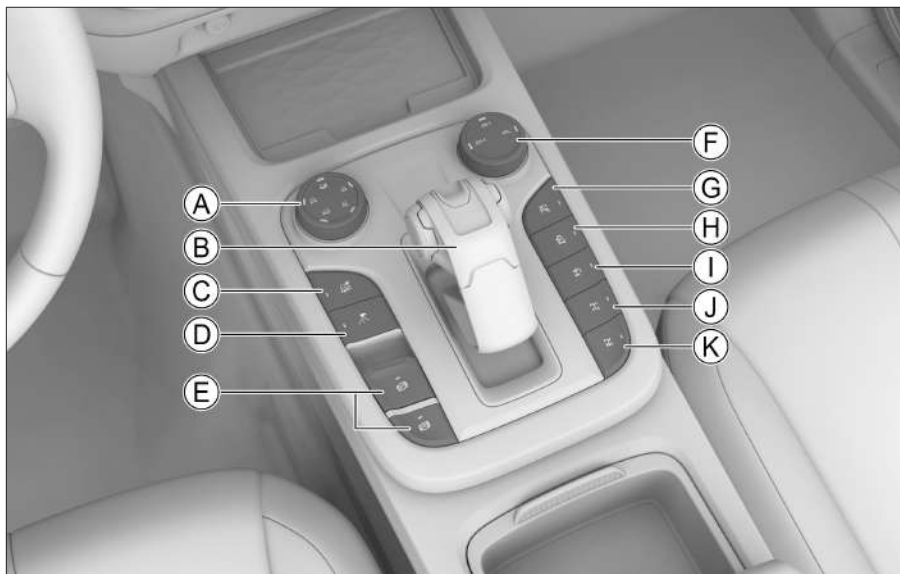

- Ⓐ All-terrain mode knob 117
- Ⓑ Gear shift 109
- Ⓒ Snow mode button 117
- Ⓓ Expert mode button 119
- Ⓔ Electronic parking brake button 105
- Ⓕ 4WD mode knob 115
- Ⓖ Depending on the configuration, the button is used for:
 - Ⓗ Anti-collision radar 130
 - Ⓘ Around view monitor (AVM) 131
 - Ⓚ Off-road cruise control button 164
 - Ⓛ Steering assist button 166
 - Ⓜ Front axle electric differential lock button 123
 - Ⓝ Rear axle electric differential lock button 121

Auxiliary instrument panel - Right-hand drive models

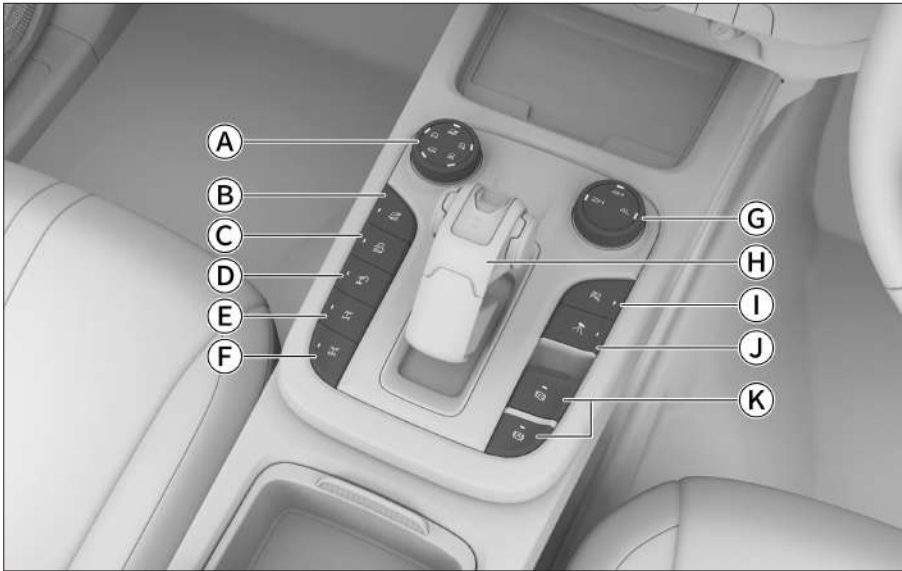

439DDA44EAA9

- Ⓐ All-terrain mode knob 117
- Ⓑ Snow mode button 117
- Ⓒ Off-road cruise control button 164
- Ⓓ Steering assist button 166
- Ⓔ Front axle electric differential lock button 123
- Ⓕ Rear axle electric differential lock button 121
- Ⓖ 4WD mode knob 115
- Ⓗ Gear shift 109
- Ⓘ Depending on the configuration, the button is used for:
 - Anti-collision radar 130
 - Around view monitor (AVM) 131
- Ⓙ Expert mode button 119
- Ⓚ Electronic parking brake button 105

Table of contents

1 Operation

This Chapter introduces the method for operating on-board vehicle equipment, such as keys, doors, windows and seats.

2 Driving

This Chapter introduces the driving information, such as vehicle start, gear shifting and instrument of the vehicle.

3 Audiovisual system

This Chapter introduces the Bluetooth telephone, system setting and other audio-visual system related information.

4 Safety

This Chapter introduces the functional equipment, such as anti-theft system and seat belts.

5 Emergency

This Chapter introduces the treatment methods for vehicle failures such as flat tyre and battery loss.

6 Maintenance

This Chapter introduces the routine inspection and regular maintenance of the vehicle.

7 Technical data

This Chapter introduces the vehicle parameters, identification number and other information.

8 Index

This Chapter introduces the alphabetical index in this manual.

Operation

Keys.....	20	Sunroof.....	34
About the key	20	Opening and closing the sunroof ..	34
Button introduction.....	20	Visor	35
Taking out the mechanical key	21	Anti-pinch function	35
Battery replacement.....	22	Thermal protection function	36
Door locks.....	24	Automatic sunroof closing.....	36
Locking and unlocking through the		Initialisation	36
PEPS	24	Bonnet.....	37
Locking and unlocking with key but-		Opening.....	37
tons	25	Closing the bonnet	37
Locking and unlocking with center		Refuelling	38
control buttons	25	Refuelling method	38
Unlocking with the interior handle		Fuel information	39
.....	25	Seats	40
Locking and unlocking with the me-		Headrest.....	40
chanical key	25	Front seat adjustments.....	41
Locking during emergencies	26	Front seat ventilation/heating.....	41
Tailgate	27	Rear seat adjustment	42
Child safety lock	29	Rear armrests.....	44
Ignition off and unlocking.....	30	Rearview mirrors	45
Auto driving lock	30	Manual anti-glare interior rearview	
Automatic resetting	30	mirror	45
Automatic unlock upon collision ..	30	Automatic anti-glare interior rear-	
Anti-misoperation lock.....	30	view mirror.....	45
Windows	31	Side mirror adjustment.....	45
Window switches	31	Side mirrors defroster function	46
Thermal protection function	32	Steering wheel.....	47
Anti-pinch function	32	How to adjust	47
Window initialization	33	Heating function	47
		Horn.....	47

Roof rack	49	Storage devices	72
Roof rack	49	Luggage hook	77
Light control	51	Off-road dining table	77
Light setting	51	Power supply socket.....	79
Light control combination switch ..	51		
Daytime running lights.....	55	Driving	
Leaving light.....	55	Driving procedures.....	84
Front fog lights auxiliary lighting ...	55	Before driving.....	84
Emergency braking warning.....	55	Precautions for driving.....	85
Hazard warning lights	56	Precautions for passengers.....	87
Light height adjustment.....	56	Parking the vehicle	88
Instrument brightness adjustment	56	Economic driving.....	88
.....	56	Advice on driving in harsh environ-	
Interior lights	56	ments.....	90
Wiper control.....	58	Driving in foggy weather	90
Front wipers.....	58	Driving in the rain	90
Rear wiper	60	Fording drive.....	91
Front wiper intelligent speed down-		Driving during the hot seasons.....	92
shift function	61	Driving in cold season	93
A/C system	62	Off-road driving alerts.....	96
A/C control panel	62	Advice on driving during run-in period	
A/C setting interface.....	64	99
A/C comfort setting.....	66	Tyres	99
A/C control	67	Friction lining of brake pad.....	99
A/C vent.....	68	Engine.....	99
Mobile wireless charging	70	Power supply switch.....	101
Instructions.....	70	Push-button type	101
Interior equipment	72	Starting and shutting down the vehicle	
Sun visor.....	72	103
Vanity mirror.....	72	Starting the vehicle	103
		Shutting down the vehicle	104

Parking brake	105	Safety function	126
Tips for safety	105	Parking assist system	128
Electronic parking brake	105	Parking assist system sensor	128
Automatic transmission	108	Anti-collision radar	130
Introduction to gear positions	108	Around view monitor (AVM)	131
Gear shifting method	109	Tyre pressure monitoring system ..	136
Unlocking P gear position in an		System introduction	136
emergency	111	Monitoring function	137
Crawling function	112	Alarm function	137
Starting off the vehicle	112	Cruise control assist system	138
Stop the vehicle	112	Cruise control assist system sensor	
Power steering mode	114	138
Switching method	114	Instructions	140
All-terrain control system	115	Queuing auxiliary function	144
All-terrain control system introduc-		Curve road auxiliary function	144
tion	115	Lane center keeping function during	
4WD switching	115	cruising	145
All-terrain switching	117	Functional limitations of the cruise	
Expert mode	119	assist	145
Operating precautions for driving		Sensor	146
4WD vehicles	120	Intelligent driving assist system	147
Differential lock	121	Intelligent driving assist system sen-	
Differential lock introduction	121	sor	147
Rear axle electric differential lock		Front assist system	150
.....	121	Lane assist system	156
Front axle electric differential lock		Side assist system	159
.....	123	Traffic sign information	161
Intelligent start-stop system	125	Off-road cruise control assist system	
Intelligent start/stop system intro-		164
duction	125	Off-road cruise	164
Instructions for use	125	Turn assist	166

Hill descent control system (HDC)..	168	Instrument panel control.....	179
Hill descent control system intro- duction	168	Instrument indicator lights.....	182
Instructions.....	168	Instrument indicator lights.....	182
Driving assist system.....	169	Power management system	191
Driving assist system safety tips.	169	System description	191
Anti-lock brake system.....	169	Information you should know.....	192
Electronic braking force distribution system	170		
Braking force assist system.....	170	Audiovisual system	
Traction control system	170	Safety tips	194
Rollover prevention system.....	170	Tips for safety.....	194
Secondary collision mitigation sys- tem.....	170	About the use.....	194
HHC (Hill-start Hold Control).....	170	About the radio	194
Electronic power steering system	171	About USB storage devices	194
Electronic stability control system	171	About Bluetooth.....	195
Dynamic stability assist system ..	172	Panel introduction	196
Emission control system.....	173	Steering wheel button.....	196
Reminder.....	173	Control panel.....	197
Oxygen sensor.....	173	External devices	197
Catalytic converter	173	Display screen introduction	199
Turbocharger.....	174	Display screen status bar	199
Fuel evaporation control unit.....	174	Interface introduction	200
Crankcase emission control unit	174	Home	200
On-board diagnostic system	174	Menu.....	200
Gasoline particulate filter	175	Shortcut panel.....	202
Virtual instrument panel.....	177	Bluetooth phone.....	203
Instrument panel overview	177	System setting	205
		Safety	
		Seat belts	210
		Safety tips.....	210
		Wear the seat belt properly.....	211

Pretensioner seat belt.....	212	Vehicle lifting position.....	233
How to use the three-point seat belt	213	Spare tyre.....	234
Airbags	214	Spare tyre introduction.....	234
Tips for safety.....	214	Removing and restoring	234
Airbag	215	Replacing the spare tyre.....	237
Front airbags	215	Tyre failure symptom	237
Side airbag	218	Preparation for spare tyre replace- ment.....	237
Curtain airbag.....	218	Method to replace the spare tyre	238
Far-end airbag.....	220	In case of a vehicle accident.....	241
Child restraint system	221	Traffic accidents occur to the vehicle	241
Safety instructions for child seat	221	Jump start	242
Fixing points for child seat.....	222	Symptoms of a drained vehicle bat- tery	242
Recommended child seat categories	223	Jump start method.....	242
Installation of child seat.....	223	Engine overheating.....	244
Vehicle anti-theft system	226	Engine overheating.....	244
System introduction	226	Towing.....	246
Instructions.....	226	Towing with a professional vehicle	246
Fuel shutoff system	228	Towing with the tow hook	247
Fuel shutoff system	228		
Event data recorder.....	229		
System introduction	229		
Data reading	229		
Data disclosure.....	229		

Emergency

On-board tools.....	232
Storage location for on-board tool kit.....	232
Vehicle lifting	233

Maintenance

Necessity of vehicle maintenance..	252
Engine compartment	253
Safety tips.....	253
Fluid level	254
Engine oil.....	255
Engine coolant.....	256

Brake fluid.....	257	Wheel parameters	280
Windscreen washer fluid	257	Braking parameters.....	281
Radiator and fan	258	Seat parameters.....	281
Battery	258	Oil parameters	282
Safety labels and signs.....	259		
Engine compartment warning label	259		
Radiator cover warning label	259		
Battery warning label	259		
Part replacement.....	261		
Fuses.....	261		
Disassembly and assembly of instru- ment panel storage box.....	263		
Wiper blades.....	264		
Lamp maintenance.....	266		
Vehicle maintenance.....	267		
Tyre maintenance	267		
Sunroof maintenance.....	269		
Exterior maintenance.....	270		
Interior maintenance	272		
Anti-corrosion measures	274		
Long-term storage of the vehicle	275		

Index

Alphabetical index	286
--------------------------	-----

Technical data

Vehicle identification.....	278
Vehicle identification number	278
Engine number.....	279
Overall parameters	280
Basic parameters	280
Power parameters	280
Tyre specifications	280



1

Operation

Keys	20
Door locks.....	24
Windows	31
Sunroof	34
Bonnet.....	37
Refuelling.....	38
Seats	40
Rearview mirrors	45
Steering wheel	47
Roof rack.....	49
Light control	51
Wiper control	58
A/C system.....	62
Mobile wireless charging.....	70
Interior equipment.....	72

Keys

Vehicle equipment

Please note that this manual contains all the standard equipment, country-specific equipment and special equipment for this model series. Thus, some equipment or features described in this manual may not be installed onto your vehicle or are only available in some markets. For further configuration information, please refer to relevant sales information or consult with your distributor selling the vehicle to you.

About the key

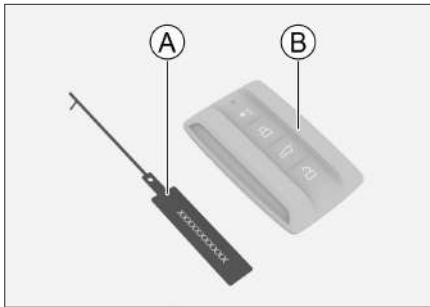

BB1182DFE914

- Ⓐ Key number tag
- Ⓑ Smart key

i NOTICE

- › Store the key number tag in a safe place. The key number tag has a code necessary for getting a new mechanical key. You may only request for a new mechanical key from the authorised service centre by using this code.

- › When purchasing or transferring the vehicle, hand over the key number tag to the purchaser.

⚠ CAUTION

The smart key contains electronic components and you should follow the following instructions to prevent damage to the smart key:

- › Do not place the key in a hot place, such as on the instrument panel.
- › Do not disassemble it randomly.
- › Do not use the key to forcefully strike other objects or drop it on the ground.
- › Do not immerse the key in water or clean it in an ultrasonic cleaner.
- › Do not place the key with devices that emit electromagnetic waves, such as mobiles.

Button introduction

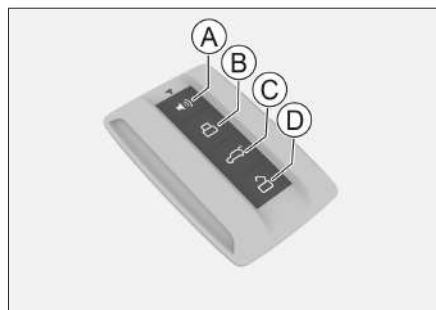

24C52319FAAE

- Ⓐ Vehicle locating button
- Ⓑ Lock button
- Ⓒ Tailgate control button
- Ⓓ Unlock button

Unlock button

Press the unlock button and the hazard warning lights will flash twice and all doors and the tailgate will be unlocked.

Lock button

Press the lock button and the hazard warning lights will flash once and all doors and the tailgate will be locked.

i NOTICE

When the door is locked, if the hazard warning lights do not flash, check whether all the doors, the tailgate and the engine hood are closed fully.

Vehicle locating button

When all the doors and tailgate are locked, press the vehicle locating button to turn on the vehicle locating function so that you can find the vehicle quickly in the parking lot and other places.

Press it again during vehicle locating alarm to cancel the locating function.

i NOTICE

The vehicle locating mode can be set through the **【Vehicle Setting】** → **【Light Setting】** → **【Mode Setting】** on the multimedia display screen.

Tailgate control button

Press and hold the tailgate control button to unlock the tailgate and press the tailgate microswitch to open the tailgate within 30 seconds after unlock.

! CAUTION

- › Do not modify the transmission frequency, enlarge transmission power (including additionally installing a radio frequency power amplifier), connect an external antenna, or use other transmitting antennas.
- › The use shall not cause harmful interference to all kinds of legitimate radio communication services. Once interference is detected, the use shall be stopped and measures shall be taken to eliminate the interference before the use can continue.
- › The use may be subject to interference from various radio devices, resulting in a brief failure of function.

Taking out the mechanical key

1. Push the key cover plate in the direction shown in the figure and remove it.



13514FCD0838

Keys

1

Operation

2. Push out the mechanical key and remove it.



ZD7A9CE72B30

3. Rotate the handle of the mechanical key to the service state.

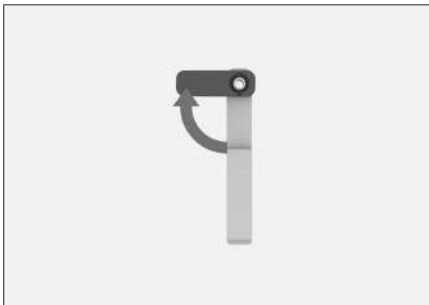

D9C3DA1393B0

⚠ CAUTION

The handle of the mechanical key can only rotate in one direction, and the maximum opening angle is about 135 degrees.

Battery replacement

⚠ WARNING

The vehicle key contains a button battery.

- › The button battery in the vehicle key is dangerous. Regardless if it is a new battery or an old one, always keep it away from children.
- › If the button battery is swallowed or put into any part of the body, it may cause severe or fatal injury in 2 hours or less.
- › Seek medical attention if you suspect the battery has been swallowed or placed in any part of the body.
- › Please dispose of used batteries according to local laws. Incorrect disposal of used batteries will damage the environment.

Battery warning label (only visible in some countries, e.g. Australia)



⚠ CAUTION

- › During operation, be sure to dry your hands. Moisture may cause the battery to rust.
- › Do not touch or move any other parts.
- › The positive and negative terminals of the battery must be installed correctly.
- › Be careful not to lose parts when replacing the battery.

1. Follow the steps to take out the mechanical key. (> Page 21)

2. Use a flat-head screwdriver to gently pry open the key and take out the key.

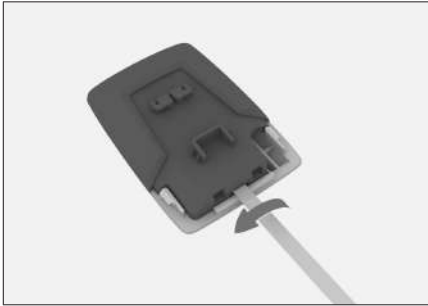

F99C9531C9C9

3. Check the position of the old battery and directions of its positive and negative terminals, then take out the old battery and replace it with a new battery. Make sure that the directions of its positive and negative terminals are installed correctly.



3A6B38020E9F

Battery model: CR2032

4. Assemble the key and test whether all the key buttons can work normally.

Door locks

Vehicle equipment

Please note that this manual contains all the standard equipment, country-specific equipment and special equipment for this model series. Thus, some equipment or features described in this manual may not be installed onto your vehicle or are only available in some markets. For further configuration information, please refer to relevant sales information or consult with your distributor selling the vehicle to you.

Locking and unlocking through the PEPS

When you carry a smart key with you, you can use the passive entry and passive start system (PEPS) to lock and unlock the door.

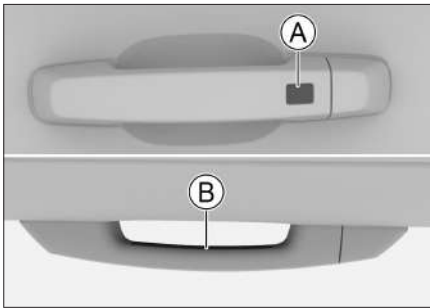

- Ⓐ Lock sensor
- Ⓑ Unlock sensor

Unlocking

Touch the unlock sensor, and the turn signal lights flash twice to unlock all the doors and the tailgate.

Locking

Touch the lock sensor, and the turn signal lights flash once to lock all the doors and the tailgate.

i NOTICE

When the door is locked, if the turn signal lights do not flash, check whether all the doors, the tailgate and the bonnet are closed fully.

i NOTICE

- › Only the doors with a smart key detected can be operated.
- › Do not lock and unlock the doors at the same time.
- › If you wear gloves to operate the door handle, you may not be able to unlock or lock the doors.
- › The radio waves of the PEPS are a little weak. When they are surrounded by other radio equipment or blocked by other barriers, the communication between the smart key and the vehicle may be affected and the system will not work normally.
- › Every time the door is successfully locked or unlocked, the PEPS system will stop working for 3 s.

i NOTICE

About outer door handle:

After washing the vehicle in the cold season, please promptly wipe off any water stains on the gaps of the outer door handles. The accumulated water stains may freeze on the handle movement mechanism, causing the door handle clamping. For example, after the door handle is pulled up, it may not be able to return to its original position, resulting in the door not being able to close properly. In this case, you can repeatedly pull the door handle several times to remove icing.

If the button indicator lights up, it means the door is locked.

If the button indicator goes out, it means the door is unlocked.

Unlocking with the interior handle



892712A7D240

When a vehicle door is locked, pulling the interior handle will unlock it. Pull the handle again to open the door.

i NOTICE

If the child lock is activated when opening the rear doors with the inner handle, the rear doors cannot be opened.

Locking and unlocking with key buttons

See the key button for introduction.
(▷ Page 20)

Locking and unlocking with center control buttons



943AE5AB3667

The center control button is located on the driver's door. Press the central control buttons to lock or unlock all doors.

Locking and unlocking with the mechanical key

1. Insert the mechanical key into the hole under the door lock cover, turn the key in the direction of the arrow, and pry the cover down.

Door locks

For how to get the mechanical key, see Taking Out the Mechanical Key.
(▷ Page 21)

Locking during emergencies

1

Operation

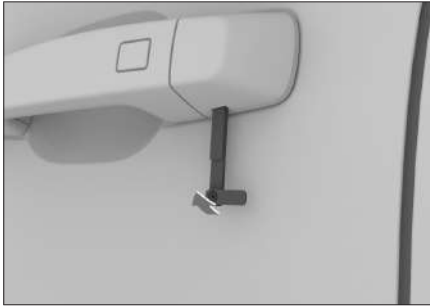

2. Insert the mechanical key into the door lock hole, and turn the key to lock or unlock the door.



i NOTICE

When the mechanical key is used to unlock the vehicle door, the vehicle anti-theft alarm may be triggered.

(▷ Page 226)



The front passenger's door and the rear door are equipped with the door emergency locking device.

Insert the mechanical key into the emergency lock hole, rotate the lock hole in the direction of the arrow on the lock hole, and then close the door to lock the door.

For how to obtain the mechanical key, please refer to Taking out the mechanical key.(▷ Page 21)

i NOTICE

If you need to use this method to lock the door, it means that the electric door lock system has malfunctioned. In this case, please go to the authorised service centre for maintenance as soon as possible.

Tailgate

Manual tailgate

Opening

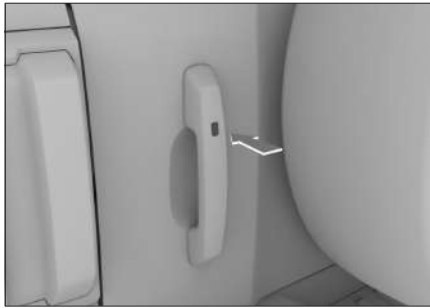

7148FDA83B73

- › When carrying the smart key with you, press the tailgate micro switch while pulling the tailgate outwards.
- › When the power supply is set to the OFF mode, press and hold the tailgate control button on the key, and pull the tailgate outwards while pressing the tailgate microswitch within 30 seconds.
- › When the driver door is unlocked, press the tailgate micro switch while pulling the tailgate outwards.

Keeping the tailgate open

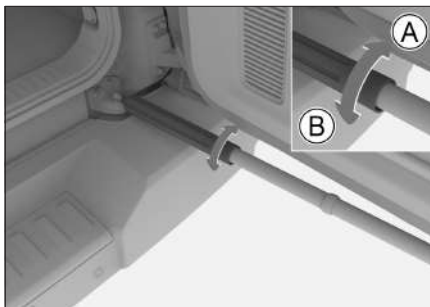

5BD9CF196500

Ⓐ Unlocking the tailgate check

Ⓑ Locking the tailgate check

You can only use the tailgate check when it is completely open.

When closing the tailgate, be sure to rotate the tailgate check to the unlocked state.

⚠ CAUTION

When the tailgate is opened, the right tail light and the retro-reflector will be blocked by the tailgate and the spare tyre. When parking on the road, use triangle warning signs or other equipment to remind other vehicles and pedestrians to pay attention to the vehicle in accordance with local laws if the tailgate is opened.

Closing

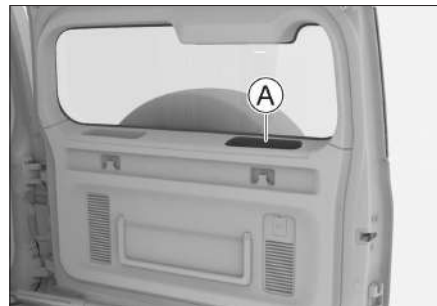

F2F6718F97C7

Ⓐ Assist handle

1. Check and confirm that the tailgate check is unlocked.
2. Pull the tailgate assist handle and release the assist handle before the tailgate is fully closed.

Door locks

3. Push the tailgate from outside to close it completely.

⚠️ WARNING

- › When closing the tailgate manually, be sure to press the tailgate outside to make it completely closed. Using the handle to close the tailgate can pinch your hand and result in serious injury.
- › Do not drive the vehicle when the tailgate is open.
- › No one should ride in the luggage area.
- › Be careful not to injury anyone near the tailgate when opening or closing.
- › When closing the tailgate, be careful not to pinch any object, such as a bag or necktie.
- › Do not allow children to operate the tailgate. Otherwise, an accidental injury may be caused.
- › Be cautious when opening or closing the tailgate in windy conditions as the tailgate may suddenly move under strong wind.
- › If the tailgate check is not locked, the tailgate may close. Opening or closing the tailgate while on a slope requires more force than when on level ground. Thus, you should watch out for it opening or closing by itself.

⚠️ CAUTION

- › Do not use excessive force when opening the tailgate; otherwise, it will easily damage the tailgate.
- › If the tailgate is frozen or covered in snow and ice, do not force it open. First use the A/C heating function to warm the interior of the vehicle, and then open the tailgate.

If you must open the tailgate in an emergency, pour warm water on it to melt the ice. Once the frozen spots loosen, try to open it.
- › Do not install or paste any accessories on the tailgate check.
- › Do not lean, climb or place your luggage on the tailgate check; do not apply external force to it in the horizontal direction.

Emergency unlock

1. Enter the vehicle, and use the mechanical key or a flat head screwdriver to pry off the emergency cover plate located inside the tailgate.

For how to obtain the mechanical key, please refer to Taking Out the Mechanical Key.(▷ Page 21)



03B5CFDE8DC9

2. Pull the cable and push the tailgate outwards to unlock and open it.



2BAD4F2B7B86

i NOTICE

If this method is used to open the tailgate, it means that the vehicle has malfunctioned. In this case, please go to the authorised service centre for maintenance as soon as possible.

Child safety lock

If there are child passengers within the vehicle, we recommend that they be seated in the comparatively safer rear seats where child safety locks are available with the corresponding vehicle doors to prevent inadvertent opening of the vehicle doors.



22915509DD81

Insert the mechanical key into the lock hole and rotate it as shown in the diagram to unlock the child safety lock. Rotate reversely to lock the child safety lock.

For how to obtain the mechanical key, please refer to Taking out the mechanical key.(▷ Page 21)

! WARNING

Only the rear doors are equipped with child locks. If a child is alone in the rear row, please activate the child locks on both rear doors at the same time to avoid accidents caused by accidental opening of the doors.

Door locks

1

Operation

i NOTICE

After the child lock is activated, the door can only be opened by pulling the door handle from outside the car.

Ignition off and unlocking

The function can be turned on or off through the **【Vehicle Setting】** → **【Driving Setting】** → **【Ignition Off and Unlocking】** on the multimedia display screen.

When the function is turned on and the engine is switched off, all doors and the tailgate are automatically unlocked.

Auto driving lock

The speed for auto driving lock can be set or the function of auto driving lock can be turned off through the **【Vehicle Setting】** → **【Driving Setting】** → **【Speed Lock】** on the multimedia display screen.

When the speed is set, all doors and the tailgate will be automatically locked when the vehicle speed exceeds the set value.

i NOTICE

Make sure that all doors and the tailgate are completely closed before driving.

Automatic resetting

When the engine hood is closed and all the doors and the tailgate are locked, if the power supply mode and the state of all the doors and the tailgate do not change within 30 seconds after the doors from outside the vehicle are unlocked (except the mechanical key), all the doors and the tailgate will be automatically locked.

Automatic unlock upon collision

With the power in ON mode, when the system detects a collision, all doors will be unlocked automatically.

Anti-misoperation lock

When the last door is closed with the driver's door locked, all locked doors will be unlocked automatically.

Vehicle equipment

Please note that this manual contains all the standard equipment, country-specific equipment and special equipment for this model series. Thus, some equipment or features described in this manual may not be installed onto your vehicle or are only available in some markets. For further configuration information, please refer to relevant sales information or consult with your distributor selling the vehicle to you.

Window switches Driver's window switch

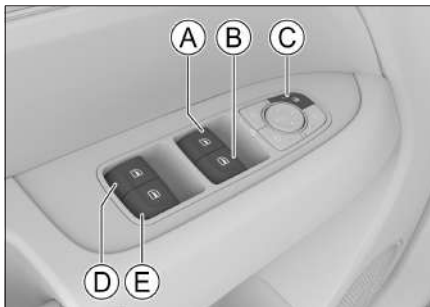

- Ⓐ Driver's window switch
- Ⓑ Front passenger's window switch
- Ⓒ Window lock switch
- Ⓓ Rear left window switch
- Ⓔ Rear right window switch

Manual operation

To lower or raise the window, press or pull up and hold the corresponding switch until the window reaches the proper position.

⚠ WARNING

Make sure that the heads and hands of all passengers are away from the window before raising the window. Otherwise, an extremely serious injury will be caused.

⚠ CAUTION

In low-temperature environment, freezing may occur between the window glass and the window frame, resulting in the failure of the glass to move normally. In this case, do not force to operate it to avoid damage to the lift mechanism. After the interior temperature rises and the ice on the glass thaws, the window can be raised and lowered normally.

One-push raising or lowering

Press the driver's window switch until it exceeds the pressure point and then release the switch. At this point, the window will automatically lower completely. To stop it halfway, just pull up the switch.

Pull up the driver's window switch till it is beyond the pressure point and then release it. The window will automatically raise completely. To stop it halfway, just press the switch.

Windows

1

Operation

i NOTICE

If the one-push raising or lowering function of the windows fails due to a battery power failure or other reasons, you are advised to initialize the windows.

Emergency raising function

In case of emergency, pull up the driver's window switch to exceed the pressure point and hold it, the window will trigger the emergency raising function, and the window anti-pinch function will not work at this time.

Locking windows

When the window lock switch is pressed, the window switches on the rear door cannot be used to control the corresponding windows.

Pressing the window lock switch again will recover the function of the rear window switches.

! WARNING

When there are children in the vehicle, it is recommended that they should sit in the relatively safe rear seats and the window lock function should be enabled.

Passenger side window switches

On the handrail of the passenger side door, there is a window switch which can be used to open or close the corresponding window.

Thermal protection function

Thermal protection may be triggered to protect the glass lifter motor after repeated operation of the window switch. At this time, the window switch will temporarily fail. The window switch automatically returns to normal after the lifter motor cools down.

Anti-pinch function

During the process of raising the window, if there is an obstacle between the window frame and the window, when the pressure reaches a certain value, the window will stop raising and automatically descend a certain distance.

i NOTICE

The function is only applicable to the driver's window.

! WARNING

- › Never test the anti-pinch function with any part of your body.
- › At the moment when the window is completely raised, the anti-pinch function will not work if something gets stuck.

- › When the window triggers the emergency raising function, the window anti-pinch function will not work.

i NOTICE

- › Under severe conditions, such as low temperature and severe bumping, the anti-pinch function may be triggered in the process of window glass raising, and the window cannot be closed smoothly. At this time, pull up the window switch until it exceeds the pressure point to raise the window.
- › When the one-push raising or lowering function is abnormal, the anti-pinch function will be disabled at the same time, and initialization can be performed to restore it to normal.

i NOTICE

When the one-push raising or lowering function is disordered or every time the battery is disconnected and re-energized, windows with one-push function need to be initialized.

Window initialization

When the window-related function is abnormal, you can reset it through the following operations:

1. Set the power supply to the ON mode.
2. Pull up the window switch equipped with one-push raising or lowering function beyond the pressure point until the window is completely closed and then hold for about 3 seconds.
3. Operate the window switch again so that the window goes through the one-push raising and one-push lowering.

Sunroof

Vehicle equipment

Please note that this manual contains all the standard equipment, country-specific equipment and special equipment for this model series. Thus, some equipment or features described in this manual may not be installed onto your vehicle or are only available in some markets. For further configuration information, please refer to relevant sales information or consult with your distributor selling the vehicle to you.

Opening and closing the sunroof

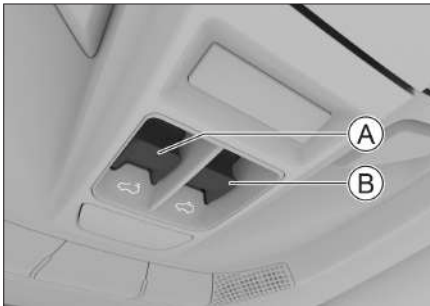

5B07C4EBE2FB

- Ⓐ Sunroof open button (press down)
- Ⓑ Sunroof close button (press down)

Slide opening and closing

Manual operation

- › Press and hold the sunroof open button, the sunroof gradually slides open.
- › Press and hold the sunroof close button, the sunroof closes.
- › To make the sunroof stop in the midway, release the button.

Automatic operation

- › Press the sunroof open button and release. The sunroof automatically opens to a comfortable position. Press and release the sunroof open button again. The sunroof automatically opens completely.
- › Press and release the sunroof close button to automatically close the sunroof.
- › To stop the sunroof halfway, press the button again.

Tilt opening and closing

Manual operation

- › Press and hold the sunroof close button, the sunroof gradually tilts open.
- › Press and hold the sunroof open button, the sunroof closes.
- › To make the sunroof stop in the midway, release the button.

Automatic operation

- › Press and release the sunroof close button, the sunroof tilts open to the maximum angle and stops.
- › Press and release the sunroof open button, the sunroof closes.
- › To stop the sunroof halfway, press the button again.

⚠ WARNING

- › Do not extend your hands or head outside through the sunroof when the vehicle is on the move. Accidental contact with outside objects or emergency braking may cause severe injury or even death.
- › When closing the sunroof, be careful not to pinch other passengers' hands, head and neck etc. to prevent serious personal injury.
- › Do not allow children to operate the sunroof.

Visor

When slide to open the sunroof, the visor opens automatically to a certain extent according to the opening angle of the sunroof.

When the sunroof is closed and only the visor is opened, pull the visor back manually to open it.

Pull the visor back manually to close it.

⚠ WARNING

- › Do not allow children to operate the visor.
- › When closing sun visor, be careful not to clip other people's hands, head and neck etc. to prevent serious personal injury.

- › It is forbidden to close the sun visor when the sunroof is opened or not fully closed, so as to prevent the sun visor from coming off and causing serious injury.

⚠ CAUTION

- › Do not squeeze the sunroof sun visor with force, so as to prevent the sun visor from falling off or being damaged.
- › When parking a vehicle for a long time, it is suggested to close the sunroof sun visor to prevent the inside decoration from being damaged due to the inside high temperature if it is exposed to the sun for a long time.

Anti-pinch function

If the sunroof encounters an obstruction during the automatic closing, it will stop closing and return a certain distance.

⚠ WARNING

- › Despite the anti-pinch function, there is still a risk of pinching.
In special cases (e.g. if the obstruction is thin), the closing process cannot be interrupted. Therefore, despite the anti-pinch function, it is important to ensure that the closing area of the sunroof remains unobstructed.

Sunroof

1

Operation

- › Do not attempt to use any part of your body to test the anti-pinch function.
- › At the moment when the sunroof is completely closed, the anti-pinch function will not work if any object is stuck.
- › When closing the sunroof manually, the anti-pinch function will not work. Be careful not to pinch fingers or other body parts.

- › The sunroof will close automatically if the vehicle speed exceeds 120 km/h.

Initialisation

When errors occur in the system, you can reset it through the following operations:

1. Set the power supply to the ON mode, press the sunroof closing button, and release the button after the sunroof is tilted to the maximum position.
2. Press the sunroof closing button again and hold it for more than 5 seconds. At this time, the sunroof will move with a "click" sound (which is a normal phenomenon). When the sunroof returns to its maximum tilting position, release the button and initialisation is complete.

Thermal protection function

Thermal protection function may be triggered to protect the sunroof motor after repeated operation of the sunroof switch. At this time, the sun roof function will be temporarily disabled, and the sunroof will fail to be operated. The sunroof switch will automatically return to normal after the motor cools down.

Automatic sunroof closing

- › When the power supply is in OFF mode, if the rainfall and light sensor senses rain or snow, etc., the sunroof will be automatically closed.

i NOTICE

In case of the little rain, the sunroof may not be closed automatically. It must be confirmed that the sunroof is completely closed before leaving.

Vehicle equipment

Please note that this manual contains all the standard equipment, country-specific equipment and special equipment for this model series. Thus, some equipment or features described in this manual may not be installed onto your vehicle or are only available in some markets. For further configuration information, please refer to relevant sales information or consult with your distributor selling the vehicle to you.

Opening

1. By pulling the handle located under the driver's side instrument panel twice continuously, the hood will pop out a gap.



4F32219637CE

2. Place your hand in the gap and lift the engine hood. Then, the engine hood will raise automatically until it is completely open.

i NOTICE

In the low temperature environment, the hood strut may not be able to support the hood automatically. When such a situation occurs, you may lift the hood manually to open it.

Closing the bonnet

Pull the bonnet downwards and close it by pressing it downwards with the appropriate force at a height of 20 to 30 cm from the lock.

! WARNING

Make sure that the bonnet is fully closed and secured prior to driving. Otherwise it may open unexpectedly during the vehicle running, leading to an accident.

! CAUTION

- › Before closing the bonnet, make sure that there is no debris left inside the engine compartment.
- › Do not use excessive force when closing the bonnet. Failure to do so may deform the bonnet.

Refuelling

Vehicle equipment

Please note that this manual contains all the standard equipment, country-specific equipment and special equipment for this model series. Thus, some equipment or features described in this manual may not be installed onto your vehicle or are only available in some markets. For further configuration information, please refer to relevant sales information or consult with your distributor selling the vehicle to you.

Refuelling method

1. When the driver side door is unlocked, press the end of the fuel tank door near the rear end of the vehicle, and the fuel tank door will pop open gently.
2. Turn the fuel tank cap counterclockwise to open it, and fix the fuel tank cap cable to the fuel tank door so as to avoid soiling the vehicle body.



C777EBE4B9F9

⚠ WARNING

- › When loosening the fuel tank cap, do not continue if you hear a whooshing sound. Once the sound disappears, you can open it slowly.

In hot weather, high-pressure fuel may be sprayed from the fuel tank filler due to large internal pressure, resulting in personal injury.

- › Take care of such matters during refuelling:

The engine must be shut down.

No smoking or naked flames are allowed in the vicinity of the vehicle.

It is not allowed to answer or make calls.

Adhere to all precautions posted at the petrol station.

⚠ CAUTION

- › Do not add too much fuel; just add it until the first automatic stop of the fuel nozzle. Otherwise, the fuel can easily enter into the carbon canister, shortening its service life.
- › Do not allow fuel to splash on the vehicle while refuelling. Otherwise, the painted surfaces may be corroded.
- › Use only the designated fuel.

3. After refuelling, put the fuel tank cap back to its original position and rotate it clockwise until you hear a “click” sound, indicating that the fuel tank cap has been installed in place.

i NOTICE

The fuel tank cap should be installed in place, otherwise the engine malfunction warning light  may go on.

4. Close the fuel tank door.

! CAUTION

Do not operate the fuel tank door violently, so as to prevent the locking mechanism from deformation and break which may result in the failure to open or close the fuel tank door.

Fuel information

Items	Data
Fuel specification	91 and above unleaded gasoline (for UAE, Qatar, Kuwait, Oman, Bahrain, Yemen, Iraq, Saudi Arabia, Australia and New Zealand)
	92 and above unleaded gasoline (for other regions)
Fuel tank capacity [L] (reference value)	80±3

Seats

Vehicle equipment

Please note that this manual contains all the standard equipment, country-specific equipment and special equipment for this model series. Thus, some equipment or features described in this manual may not be installed onto your vehicle or are only available in some markets. For further configuration information, please refer to relevant sales information or consult with your distributor selling the vehicle to you.

Headrest

Headrest adjustment

When the headrest center height is aligned with the top of the driver's or passenger's ears, it is at maximum efficiency.

⚠ WARNING

The headrest must not be adjusted while the vehicle is being driven.



40BAB340E018

- › To raise the headrest, directly pull it upwards to the desired position.

- › To lower the headrest, push the headrest down while pressing and holding the headrest adjust button until the headrest reaches the desired position.

i NOTICE

The lowest position of the headrest is not its use position. The headrest must be ascended to the locked position before use.

i NOTICE

After adjusting the headrest, press the headrest to make sure it is locked firmly.

Remove headrest

To remove the headrest, press and hold the headrest adjust button, and remove the headrest.

If necessary, adjust the seat backrest so that the headrest can be removed.

⚠ CAUTION

After the headrest is installed, push it up or down to make sure that it has been locked in place.

⚠ WARNING

The headrest must not be removed while the vehicle is being driven. If this is done and a collision occurs, the neck of the driver or passenger neck will be subject to major strain, potentially resulting in serious injury or even death.

Front seat adjustments

⚠ WARNING

- › Never adjust the seat when driving.
- › Make sure the driver's seat is adjusted to a correct position before driving. Otherwise, it may easily cause incorrect operations and may even lead to accidents, and the safety efficiency of seat belts, airbags, headrest and other devices cannot be effectively used.
- › Do not tilt the seat backrest excessively to prevent the passenger from sliding out from under the lap belt when a collision happens. The seat belts can provide the best protection only when you sit up straight and lean against the seat backrest.

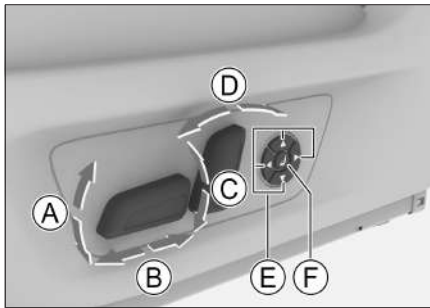

691E59F35F52

- (A) Seat cushion angle adjustment
- (B) Forwards/backwards adjustment of the seats
- (C) Seat height adjustment
- (D) Backrest inclination angle adjustment
- (E) Lumbar support adjustment

Press forward or backward button to reinforce or weaken the lumbar support.

Press upward or downward button to raise or lower the lumbar support.

(F) Seat massage function

Press the button to switch the massage function between the forced gear, the weak gear and the off gear. The massage function will stop automatically after it operates for about 15 minutes.

Front seat ventilation/heating

Setting via buttons

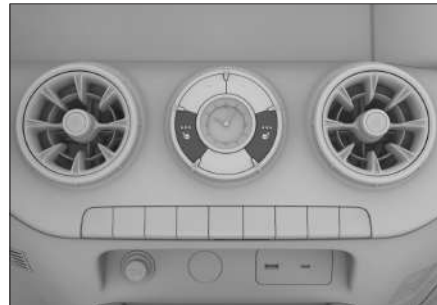

41001113CBCD

When the power supply is in ON mode, press the seat heating button to set the heating function for the corresponding seat. The indicator light on the button shows the heating level of the corresponding seat.

Seats

Setting via the display screen

- › When the power supply is in ON mode, you can choose to set the seat heating or ventilation through the **【Vehicle Setting】** → **【Seat Setting】** interface on the multimedia display screen.
Touch the OFF/ON button at the bottom to turn on or off the corresponding seat heating (or ventilation) function.
Touch or slide up or down the adjustment area on both sides to set the corresponding seat heating (or ventilation) level.
- › By touching the seat icon at the bottom of the A/C setting interface, you can set the heating (or ventilation) function for the corresponding seat in the pop-up window.

i NOTICE

The heating and ventilation functions of one seat cannot be enabled at the same time.

⚠ WARNING

When the seat heating function is activated, the following passengers must take care:

- › Infants, children, the elderly, the ill or the physically disadvantaged;
- › A person who is with sensitive skin;
- › A person who is overworked;

- › A person who is drowsy because of drinking or taking medicine.

⚠ CAUTION

- › Never modify the seat and its electrical system. Otherwise, the function and life of the seat heater may be affected.
- › To prevent seat overheating, do not place any mats, cushions or other insulating materials on the seat when the seat heating function is activated.
- › To prevent draining the battery voltage, never use the seat heating function for a long time without starting the vehicle.
- › The seat heater may be damaged when the following conditions occur, and it must be checked before use:
There is a lot of water on the seat.
The seat is pierced by sharp objects (pins or knives).
The seat smells peculiar.

Rear seat adjustment

Seat cushion flipping

i NOTICE

- › Remove all objects from the seat before flipping the seat cushion.
- › Please adjust the front seat to a suitable position to avoid interference when flipping the seat cushion.

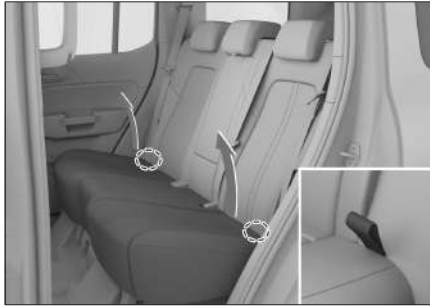

Pull up the seat cushion pull cord, pull the seat cushion forwards and upwards from under the backrest, and then flip the seat cushion forwards.

⚠ WARNING

- › Never flip the seat cushion when driving the vehicle.
- › When driving, no one is allowed to sit on the flipped seat cushion.

Backrest folding

⚠ CAUTION

When the seat cushion is not flipped forwards, the seat backrest cannot be placed flat on the seat cushion. Do not operate with brute force; otherwise, the seat will be damaged.

i NOTICE

- › Flip the seat cushion and then fold the backrest to make the backrest flat and get more storage space. Please push the seat cushion forwards slightly to keep the backrest flat.

- › Before folding, adjust the headrest to an lowest position.
- › Put the seat belt back in place to avoid interference when folding the backrest.
- › Remove all objects from the seat before folding the seat backrest.
- › Do not place heavy objects on the folded backrest.



- Ⓐ Unlocking the handle
- Ⓑ Backrest lock indicator

When the backrest is locked, the indicator is retracted (as shown in the figure); when the backrest is unlocked, the indicator is popped out.

Push forwards the unlocking handle at the top of the backrest to fold the unlocked backrest forwards.

⚠ WARNING

- › Never adjust or fold the seat backrest while the vehicle is running backrest.
- › No one is allowed to sit on a folded seat backrest or in the luggage area.

Seats

› Children are prohibited from entering the luggage area.

1

Operation

Seat restoration

1. Adjust the seat belt to avoid it being stuck under the seat during backrest restoration.
2. Pull up the backrest and return it to the original position for use. Check whether the backrest lock indicator is locked (retracted), and then shake the seat backrest slightly back and forth to ensure that it is locked in place.
3. Adjust the seat belt lock body to the vertical state to prevent the lock body from pressing down after the seat cushion is restored, and then restore the seat cushion to the use state.

Backrest angle adjustment

The backrest angle can be adjusted. Push forwards the unlocking handle at the top of the backrest to adjust the unlocked backrest to a desired angle.

After adjusting the backrest angle, check whether the backrest lock indicator is locked (retracted), and then shake the seat backrest slightly back and forth to ensure that it is locked in place.

Rear armrests



OEDA20659E89

Pull the rope outwards to lower the rear armrests to provide elbow support for the rear passengers and make the arms feel more comfortable.

Rearview mirrors

Vehicle equipment

Please note that this manual contains all the standard equipment, country-specific equipment and special equipment for this model series. Thus, some equipment or features described in this manual may not be installed onto your vehicle or are only available in some markets. For further configuration information, please refer to relevant sales information or consult with your distributor selling the vehicle to you.

Manual anti-glare interior rearview mirror



B42AE3AFD9A

- (A) Normal position
- (B) Anti-glare position

Toggle the handle to the rear of the vehicle to switch to the anti-glare position. The reflection from the headlights of the vehicle behind can be reduced at that position.

Automatic anti-glare interior rearview mirror



33C8BAFA1FA2

The interior rearview mirror will automatically reduce the reflection according to the light intensity of the headlights of the vehicle behind.

Side mirror adjustment

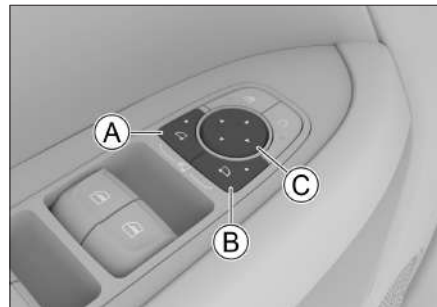

818D467A5DAA

- (A) Left side mirror button
- (B) Right side mirror button
- (C) Mirror adjustment button

Mirror adjustment

1. Press the side mirror button to select the left (L) or right (R) side mirror. If the button indicator lights up, the mirror has entered the selected state.

1

Operation

Rearview mirrors

2. Press the front, rear, left and right positions of mirror adjustment button to adjust the angle of the left or right side mirror.
3. After the adjustment, press the side mirror button again, the button indicator will go out and the mirror exits from the selected state.

WARNING

Do not adjust the side mirrors while driving. Otherwise, errors in control can lead to accidents and serious injuries or death.

Electric folding

Press the left and right side mirror buttons simultaneously and the side mirrors will automatically fold up. Press again them simultaneously and the side mirrors will automatically unfold.

Auto folding when locking the vehicle

The folding mode of side mirrors can be set through the **【Vehicle Setting】** → **【Comfort Setting】** → **【Side Mirror Folding Mode】** on the multimedia display screen.

When the automatic folding mode is set, the folding and unfolding of the side mirrors is linked with the locking and unlocking of the doors.

WARNING

- › Before driving, you must unfold the side mirrors and adjust them appropriately.
- › Be careful of your fingers when moving the side mirror to avoid injury or damaging the side mirror.

Side mirrors defroster function

For vehicles with side mirrors defroster function, the side mirrors defroster function will be activated or deactivated simultaneously with the rear defroster function of the A/C system. After this function is turned on, the frosting or fogging of the side mirrors can be gradually alleviated.

The side mirrors defroster function will be turned off automatically after it works for a period of time.

WARNING

After the defroster function of the side mirrors is turned on, do not touch the mirror surface to avoid scalding.

Vehicle equipment

Please note that this manual contains all the standard equipment, country-specific equipment and special equipment for this model series. Thus, some equipment or features described in this manual may not be installed onto your vehicle or are only available in some markets. For further configuration information, please refer to relevant sales information or consult with your distributor selling the vehicle to you.

How to adjust

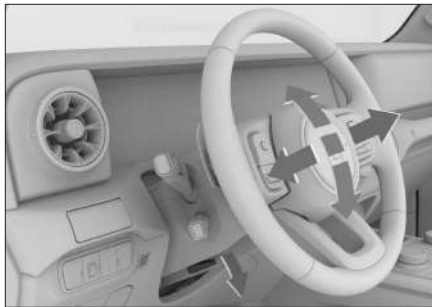

F2A08DFDC785

1. Release the adjustment lever beneath the steering wheel.
2. Adjust the steering wheel to align it to your chest and make sure you can see all the instruments and indicator lights on the instrument cluster.
3. After adjusting, retract the lever back to lock the steering wheel.

⚠ WARNING

- › Do not adjust the steering wheel while the vehicle is moving. Otherwise, incorrect operation could result in an accident or serious injury.
- › After adjusting the steering wheel, ensure that it is securely locked in place. Otherwise, sudden movement of the steering wheel could result in an accident or serious injury.

Heating function

The steering wheel heating function can be activated or deactivated through **【Vehicle Setting】** → **【Comfort Setting】** on the multimedia display screen.

⚠ CAUTION

To prevent under-voltage battery and affecting engine startup, refrain from using the steering wheel heating function for a long time when the engine is not running.

Horn

Press the horn mark on the steering wheel or its surrounding area and the horn honks.

Steering wheel

1

Operation

CAUTION

- › There is a front airbag inside the steering wheel. Do not hit the position around the horn hard to avoid the condition that the airbag cannot work normally during accident or the airbag is accidentally deployed in normal driving, which will cause serious injuries or even death to passengers.
- › Do not install any decorations on the steering wheel horn.

Vehicle equipment

Please note that this manual contains all the standard equipment, country-specific equipment and special equipment for this model series. Thus, some equipment or features described in this manual may not be installed onto your vehicle or are only available in some markets. For further configuration information, please refer to relevant sales information or consult with your distributor selling the vehicle to you.

Roof rack

To install a luggage rack on the roof rack, please read carefully the installation manual that comes with the luggage rack.

i NOTICE

When the luggage rack is installed or used for carrying items, relevant requirements of local traffic regulations should be observed.

Roof rack bearing capacity

The maximum load weight of the roof rack is 50 kg; the maximum load weight of the roof rack is 35 kg when the vehicle is decelerating rapidly.

i NOTICE

The load weight of the roof rack includes accessories such as the beam and other accessories.

! WARNING

- › Items on the roof luggage rack must be secured firmly in place. Otherwise, there is a risk of an accident.
- › Loading goods on the roof luggage rack will raise the vehicle centre of gravity. Avoid high speed driving, sudden startup, sharp turns, emergency braking or abrupt operation. Failure to do so may cause loss of control or overturn of the vehicle due to incorrect operation of the vehicle, resulting in serious injury or death.
- › When rather heavy or large objects are loaded on the roof luggage rack, changes in the vehicle centre of mass and wind resistance may affect its driving performance, and there is a risk of an accident. Therefore, you must adjust your driving style and speed according to the specific circumstances.
- › Drive at low speed in lateral wind. The vehicle profile and its high centre of gravity make it more sensitive to lateral gust, and reducing the vehicle speed will make it easier to control.
- › Do not overspeed, jolt, make sharp turns, hit objects, etc. when driving off-road or in uneven terrain. This can cause loss of control or overturn of the vehicle, resulting in serious injury or death, as well as serious damage to the suspension and chassis of the vehicle.

Roof rack

1

Operation

- › Do not cross steep slopes, and it is better to drive straight up or down. The vehicle is more likely to roll over than to roll forward or backward.
- › The roof luggage rack can only be used with the sunroof closed. Otherwise, the roof luggage rack or the items loaded on it may cause injury to passengers.

Vehicle equipment

Please note that this manual contains all the standard equipment, country-specific equipment and special equipment for this model series. Thus, some equipment or features described in this manual may not be installed onto your vehicle or are only available in some markets. For further configuration information, please refer to relevant sales information or consult with your distributor selling the vehicle to you.

Light setting

You can set the functions related to the light through the **【Vehicle Setting】** → **【Light】** interface on the multimedia display screen.

Time setting

- › **【Power Saving Delay Time】** : you can set the effective time of the power saving function.

After the power supply is switched to OFF mode, if the power supply mode, door lock and hazard warning light states do not change within the set time range, the power saving function will automatically turn on to save power.

- › **【Roof Light Timing】** : you can set the time when the interior lights are turned off after all doors are closed when the interior lights are on with the door control function turned on.

- › **【Leaving Light Timing】** : you can set the continuous lighting time of the parking lights and the low beams after the leaving light function is triggered.

Ambient light setting

You can set the working state of the ambient light.

Mode setting

【Find Car Mode】 : you can set the vehicle prompt mode when the find car function is triggered.

Light control combination switch

Main light knob

i NOTICE

Before you lock and leave the vehicle, please turn the main light knob to the OFF or AUTO position to reduce the power consumption of the vehicle and prevent the draining of voltage from the battery thus affecting the normal use of the vehicle.

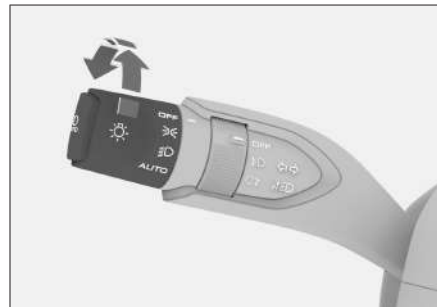

DOF97216C02B

Light control

1

Operation

- › Turn the main light knob to the clearance light  position to turn on the position light and the license plate light.

CAUTION

Do not use the position light instead of the low beam headlight when driving. Otherwise, there is a risk of an accident.

The position lights are not bright enough to illuminate the road in front of your vehicle or allow other vehicles and pedestrians to see your vehicle. Therefore, turn on the low beam headlights when it's dark or visibility is poor.

- › Turn the main light knob to the low beam headlight  position to turn on the low beam headlights and keep the position light and the license plate light on.
- › Turn main light knob to the AUTO position. The clearance lights and low beam headlight will be turned on or off automatically according to the brightness of the surrounding environment.

CAUTION

- › When visibility is affected in the day due to heavy fog, the lights may not illuminate automatically. Turn on the lights manually in this case.



- › Auto light control can only assist the driver. At all times, the driver should be responsible for the lighting of the vehicle.

- › Turn the main light knob to the OFF position to turn off all vehicle lights.

Fog light knob



D9AA17A1B508

- › When the clearance lights (position light, license plate light) go on, turn the fog light knob to the front fog light position  to turn on the front fog lights.
- › When the low beam headlights or the front fog lights go on, turn the fog light knob to the rear fog light position  repeatedly to turn on or off the rear fog lights. When released, the knob will automatically return.

Turn signal and lane change signal

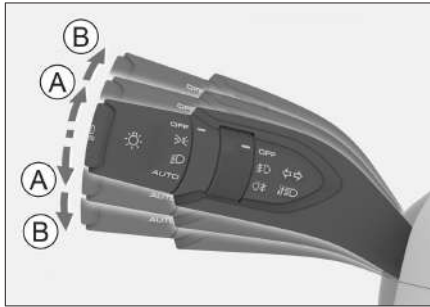

B6DD20687049

Ⓐ Lane change signal

Ⓑ Turn signal

- › Lane change signal: pull up or push down the light control combination switch gently and release it, and then the light control combination switch will return automatically and the corresponding turn signal light will flash 3 times.
- › Turn signal (type 1): pull up or push down the light control combination switch and release it, then the light control combination switch will not return automatically and the corresponding turn indicator will flash continuously.

Turn signal (type 2): pull up or push down the light control combination switch and release it, and then the combination switch will return automatically and the corresponding turn indicator will flash continuously, and go off automatically after the steering is completed. Slightly toggle the light control combination switch upwards or downwards to manually turn off the turn indicator.

Manual low-high beam

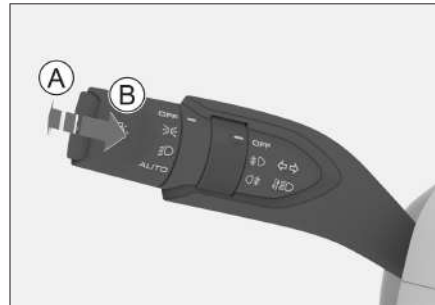

565CC4E49B7F

Ⓐ High beam headlight on

Ⓑ High beam headlight flashing

- › When the low beam headlights are on, press the light control combination switch in a direction away from the steering wheel to turn on or off the high beam headlights; when you release the light control combination switch, it returns automatically.

Light control



- › The high beam headlights go on when you pull the light control combination switch up in a direction along the steering wheel; when released, the light control combination switch automatically returns and the high beam headlights go out. You can repeat this operation to make high beam headlights flash.

Auto low-high beam



07B558A834B1

Auto low-high beam function can automatically switch between high and low beam headlights based on current vehicle speed and ambient brightness.

When the low beam headlights are on and the high beam headlights are off, press the auto high beam toggle switch  to turn on or off the auto low-high beam function. After the function is turned on, the auto high beam indicator light  on the instrument panel turns on in green.

⚠ WARNING

Auto switch between low and high beam headlights is only an auxiliary function. When traffic conditions or weather conditions require, the driver should manually switch between high and low beam headlights according to the light and visibility conditions. Manual intervention is required in the following cases:

- › Weather conditions are not conducive to driving, such as heavy fog or rain or snow.
- › You turn sharply or drive on the slope.
- › You are at a junction or you cannot see the opposite traffic completely, such as when the light of the opposite traffic is obscured by a collision barrier or when you are travelling on motorway.
- › You are driving in areas with poor lighting conditions and many buildings.
- › There are traffic participants with poor lighting around the road, such as pedestrians or non-motorized vehicles.
- › There are highly reflective objects near the road, such as traffic signs.
- › The rainfall and light sensor on the current windscreen is dirty, frosted or covered by labels.

Daytime running lights

To allow other drivers to see your vehicle more clearly, the daytime running lights automatically illuminate when the vehicle is started.

The daytime running lights will go out when the following conditions are triggered:

- › The headlights are on.
- › When the left or right turn signal light is on, the daytime running light on the same side will turn off.

WARNING

- › The daytime running lights are not designed for the needs of night-time driving.
- › The driver is always obliged to ensure that the vehicle is driven with the correct lighting in compliance with traffic laws.

Leaving light

With the power supply in OFF mode and the master light switch in the automatic light position, if the current light intensity meets the conditions for the low beam headlamp to be on, the position lamp and the low beam headlamp will automatically illuminate for a period of time after the doors have been successfully locked from the outside of the vehicle (except for locking by the mechanical key) to ensure that you can leave the vehicle in the dark.

Front fog lights auxiliary lighting

This function can realize the automatic lighting of front fog light on the corresponding side of vehicle when turning a corner and the automatic lighting of all front fog lights when reversing, so as to better illuminate the surrounding environment.

The following conditions must be met in order to turn on the front fog lights auxiliary lighting:

- › The speed of the vehicle is less than 35 km/h.
- › The low beam headlights are turned on.
- › The turn indicator is turned on or the angle of steering wheel is greater than 60°.
- › The front fog lights are not turned on.

Emergency braking warning

If you perform emergency braking when the speed of the vehicle exceeds 50 km/h, the hazard warning lights flash fast to remind the approaching vehicle to avoid the risk timely.

Light control

Hazard warning lights

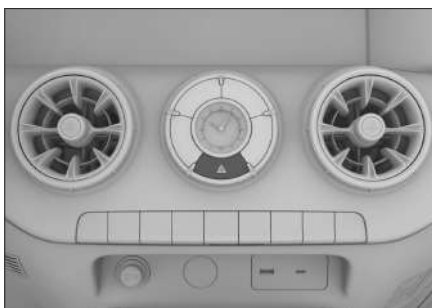

73943FBEA4AF

In case of vehicle breakdown or traffic incidents, turn on the hazard warning lights to remind other vehicles. Press the switch to turn on or off the hazard warning lights.

Light height adjustment



C0D59DDC1D62

The headlamp beam height is adjusted according to the number of passengers and the load of the vehicle.

- › Turn the knob upwards to raise the height of the headlamp beam.
- › Turn the knob downwards to lower the height of the headlamp beam.

Instrument brightness adjustment



25BF5E177FEB

- › Press the upper part of the button, and the instrument and the vehicle backlights are brightened.
- › Press the lower part of the button and the instrument and the vehicle backlights are dimmed.

Interior lights



Reading lamps

⚠ CAUTION

Do not use the interior lamps for a long time when the vehicle is not started. Otherwise, it may drain the battery.



62BFEC4C6806



- › Press the  reading lamp main switch to turn on or turn off the reading lamps.
- › Press the  door-control switch to enable or disable the door control function.

With the door-control function enabled, the reading lamp will turn on or turn off automatically according to the door condition.

Roof lamp



A38991EAA621

- › Press the  door-control switch to enable or disable the door control function.
With the door-control function enabled, the roof lamp will turn on or turn off automatically according to the door condition.
- › Press the  switch to turn on or turn off the corresponding roof lamp.

Luggage-area light

When the tailgate is open or closed, the luggage-area lights turn on or off automatically.

Wiper control

Vehicle equipment

Please note that this manual contains all the standard equipment, country-specific equipment and special equipment for this model series. Thus, some equipment or features described in this manual may not be installed onto your vehicle or are only available in some markets. For further configuration information, please refer to relevant sales information or consult with your distributor selling the vehicle to you.

Front wipers

Front wiper gear

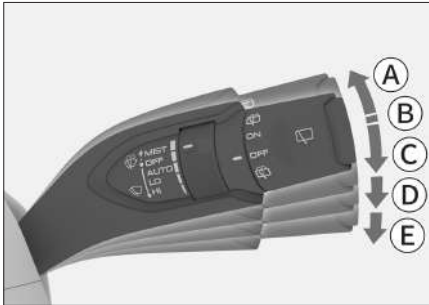

275CCCA3323B

Ⓐ Front wiper mist (MIST)

Move the wiper control combination switch upwards to the MIST position. Once you release it, it will return to its original position. The front wiper will operate once.

Ⓑ Front wiper off (OFF)

Ⓒ Automatic (AUTO)

Ⓓ Low speed (LO)

Ⓔ High speed (HI)

⚠ CAUTION

- › If the surface of the windscreen is dirty or has any foreign object (snow, gum, etc.), clean it first and remove the foreign object. Otherwise, the wiper blade or the internal structure of the wiper may be damaged.
- › Before using the wiper in the cold season, be sure to check whether the wiper blade is frozen on the windscreen. If the wiper blade has been frozen on the windscreen, you should use it after unfreezing. Otherwise, the wiper blade and wiper motor may be damaged.
- › When the wiper stops running due to snow and other reasons, please turn off the wiper and park the vehicle in a safe place as soon as possible, and then remove snow and other debris so that the wiper can work normally.

Adjustment of auto wipe frequency



4C411A8EFC4D

Wiper control

Turning the adjustment knob can change the sensitivity of the rainfall and light sensor to the rain, thereby changing the wipe frequency of the front wiper when it is at the automatic (AUTO) gear.

⚠ WARNING

- › The rainfall and light sensor may not fully recognize each fall of rain and activate front wipers. If the rain on the windscreen affects the vision, you should manually adjust front wiper position or scraping frequency duly as required.
- › When the automatic front wiper is in the AUTO position, the front wiper may operate unexpectedly if the windscreen near the inside rearview mirror is touched from outside or the windscreen is vibrated. Be careful not to get your fingers and other parts of your body caught in front wipers.
- › Do not place the automatic front wiper in the AUTO position when you wash the car or no front wiper is required to be used. Otherwise, front wipers may operate unexpectedly.

⚠ CAUTION

- › If the surface of the windscreen near inside rearview mirrors is dirty or has any foreign object (snow, gum, etc.), clean it first and remove the foreign object, otherwise it may affect the normal work of the auto wiper.
- › Sometimes, even if snowflakes come in contact with the rainfall and light sensor, the sensor may not operate normally and front wipers may not function, as snowflakes come in different shapes. The melted snow may cause front wipers to automatically operate.

Washing function



930465496923

Pull up and hold the wiper control combination switch towards the steering wheel, and the front wipers will use windscreen washer fluid to wipe the front windscreen. When it is released, the combination switch will return automatically to its original position.

Wiper control

1

Operation

⚠ CAUTION

- › Avoid using the washer continuously for a long time. Otherwise, the washing motor may be damaged.
To protect the washing motor, the washer may automatically shut down after a period of continuous operation.
- › When the washer fluid is insufficient, replenish it. In the cold season, add appropriate washer fluid to ensure that it will not freeze. Otherwise, not only the washing function will not be available, but also the related parts will be frozen.
- › Do not use products that can produce coatings on the windscreen (cleaning solutions for crystal plating or coating, glass coatings, etc.). Otherwise, abnormal vibration and noise may occur during the wipe by the wiper.
- › The blade cannot get contact with oily cleaning agent. They may react chemically which may cause blade deformity.

Rear wiper



2603A334FC8A

- › Turn the rear wiper control knob to the ON position and the rear wiper will turn on.
- › Turn the rear wiper control knob to the rear windscreen cleaning position  and hold. The rear wiper will wipe the rear windscreen using screen washer. Release the control knob and it will return automatically to its previous position.
- › Turn the rear wiper control knob to the OFF position to turn off the rear wiper.

⚠ CAUTION

- › Do not use products that produce a coating on the windscreen (e.g. crystallised or coated washing liquid, glass coatings, etc.). Otherwise, this may cause the wiper to bounce and rattle when wiping.

- › Do not allow the wiper blades to come into contact with oil-based cleaning products, as this may cause a chemical reaction and lead to severe deformation of the wiper blades.

Front wiper intelligent speed downshift function

If the front wiper is in the high-speed wiping position, when the vehicle speed exceeds 12 km/h and then decelerates to below 4 km/h, the front wiper will automatically reduce the frequency of wiping; when the vehicle speed exceeds 12 km/h, the wiper will automatically return to the wiper frequency of the current position.

A/C system

Vehicle equipment



Please note that this manual contains all the standard equipment, country-specific equipment and special equipment for this model series. Thus, some equipment or features described in this manual may not be installed onto your vehicle or are only available in some markets. For further configuration information, please refer to relevant sales information or consult with your distributor selling the vehicle to you.

A/C control panel





F774D87395FB

i NOTICE

The positions of the front defroster button  and rear defroster button  may not be the same as those shown in the illustration due to different model configurations. Refer to the actual vehicle.

- › Press the button  to turn on or off the A/C system. The corresponding indicator light goes on, indicating that the A/C has been turned on.

- › Press the A/C button to activate or deactivate the cooling mode. The corresponding indicator light turns on, indicating that the cooling mode is activated. In this mode, the inside temperature and humidity may be reduced.
- › Press the airflow decrease button  to decrease the airflow.

Press the airflow increase button  to increase the airflow.

- › Press the MODE button to switch the airflow distribution mode.
- › Press the down button  to lower the temperature.

Press the up button  to raise the temperature.

- › Press the internal circulation button  to turn on or off the internal circulation mode. The corresponding indicator light is on, indicating that the internal circulation mode has been turned on. If the button indicator light goes out, it indicates that the external circulation mode is turned on.

i NOTICE

- › Normally, the external circulation mode should be used. Using the internal circulation mode tends to cause windows to fog, especially when the compressor is turned off.

A/C system

- › The internal circulation mode should be used under circumstances such as driving through a tunnel, in traffic jams, dirty air outside the vehicle or when quick cooling and heating is desired.
- › Press the AUTO button to activate the automatic mode. The corresponding indicator light goes on, indicating that the automatic mode is activated. The A/C system will automatically adjust the airflow distribution mode and the airflow to reach the set temperature.

i NOTICE

If the airflow distribution mode and the airflow automatically adjusted by the A/C system cannot meet your demand, you can perform manual adjustment; in this case, the system will exit the AUTO mode, and the indicator light will go out.

- › Press the front defroster button  to enable or disable the front defroster function. The corresponding indicator light goes on, indicating that the front defroster function has been enabled. In this case, the frosting and fogging of the front windscreen and the side door glass can be gradually eliminated.

- › Press the rear defroster button  to enable or disable the rear defroster function. The corresponding indicator light goes on, indicating that the rear defroster function has been enabled. In this case, the frosting of the rear windscreen can be gradually eliminated.

! WARNING

Once the rear defroster function has been enabled, the rear windscreen will become hot. Do not touch it to avoid burns.

! CAUTION

When the vehicle is not started, do not use the rear defroster function for a long time, so as to prevent the draining of the battery voltage.

A/C system

A/C setting interface

1

Operation

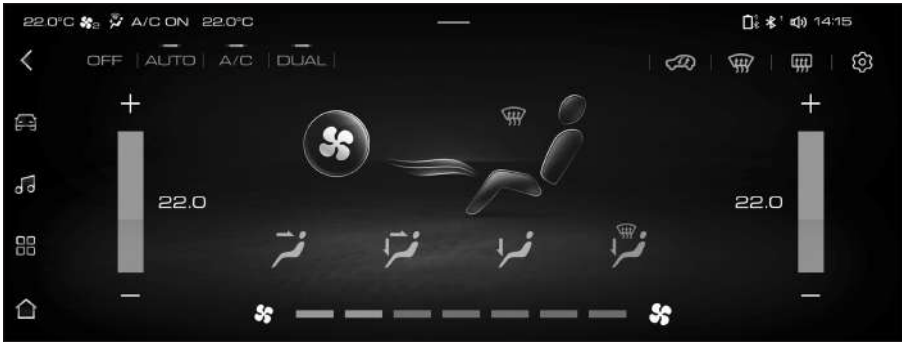

A49C7E5DB1DA

- › Touch the OFF button to turn off the air conditioning system.
- › Tap AUTO button to activate the automatic mode. In this mode, the air outlet mode and the air volume can be automatically adjusted to reach the set temperature.

i NOTICE

If the automatic air-out mode and air flow volume adjusted by the A/C system cannot meet your demand, you can perform manual adjustment; in this case the system will exit the AUTO mode, and the indicator will go out.

- › Tap A/C button to activate or deactivate the cooling mode. After the cooling mode is enabled, the inside temperature and humidity may be reduced.
- › Tap the DUAL button to activate or deactivate the zoning control mode.
After the zoning control mode is activated, the temperature at the driver's side and the front passenger's side can be adjusted respectively.
After the zoning control mode is deactivated, the temperature at the front passenger's side will change with that at the driver's side.

i NOTICE



The A/C system will automatically enable the zoning control mode when the temperature on front passenger's side is adjusted.

- › Touch the  circulation mode button to make the A/C system switch between the internal and external circulation modes.
The corresponding indicator lights up, indicating that the internal circulation mode has been turned on.

A/C system

The corresponding indicator is extinguished, indicating that the external circulation mode has been turned on. In this case, the air outside the vehicle can be introduced into the vehicle.

NOTICE

- › Normally, you should put the system in external circulation mode. Use of internal circulation mode tends to cause foggy windows, especially when the compressor is turned off.
- › The internal circulation mode should be used under such circumstances as the tunnel, traffic jam, dirty air outside the vehicle or quick cooling and heating desired.
- › Touch the  front defroster button to enable/disable the front defroster function. The corresponding indicator lights up, indicating that the front defroster function has been turned on, and the frosting and fogging of the front windscreen and the side door glass can be gradually relieved.
- › Touch the  rear window defroster button to enable/disable the rear window defroster function. The corresponding indicator lights up, indicating that the rear window defroster has been turned on. At this time, the frosting of the rear window can be relieved gradually.





The rear window defrosting function will turn off automatically after it has been turned on for a period of time, and the corresponding indicator will go out.

WARNING









Once the rear window defrosting function has been enabled, the rear windscreen will become hot. Do not touch it to avoid burns.

CAUTION

When the vehicle is not started, please do not use the rear window defrosting function for a long time, so as to prevent the battery power from being drained.

- › Touch the  cooling button or the  heating button to adjust the temperature. Touch or slide the area between the  cooling button and the  heating button to adjust the temperature.

A/C system

- › Touch the  face-blowing mode button , the  feet and face-blowing mode button , the  feet-blowing mode button , or the  feet-blowing and defroster mode button to select the corresponding blowing mode.
- › Touch or slide the  air volume down button and the  air volume up button to adjust the air volume.
Touch or slide the area between the  air volume down button and the  air volume up button to adjust the air volume.

A/C comfort setting

On the A/C setting interface, touch the  A/C comfort setting button and the A/C comfort setting interface will be popped up.

In the A/C comfort setting interface, the comfort effect of the A/C system in AUTO mode can be set:

- › Soft: The cooling or heating effect of the A/C system is softer with smaller air volume compared with the standard mode.
- › Standard: The A/C system automatically controls the outlet temperature and air volume according to the temperature set by the user.
- › Powerful: The cooling or heating effect of the A/C system is stronger with larger air volume compared with the standard mode.

A/C control

Cooling/heating

After starting the vehicle:

1. Select the **【AUTO】** mode and the corresponding indicator light will turn on. At this moment, the **【A/C】** indicator light will come on, and the compressor will be automatically turned on or off depending on the temperature and the environment.
2. Set the temperature to your desired value. The A/C system will automatically adjust the air distribution mode and the airflow to achieve the set temperature.
3. Selecting the internal circulation mode may speed up cooling or heating and help to improve the economy of the vehicle.

Front defroster/front defogger

After starting the vehicle:

1. Select the front defroster mode, and the corresponding indicator light will turn on.
2. You can also adjust the airflow or the temperature, turn on or off the compressor, or switch between the internal and external circulation modes on demand.

i NOTICE

If the air is dirty or fog is formed inside the car, switch to external circulation mode.

! CAUTION

- › Check the radiator and the A/C condenser on a regular basis. Use a low-pressure water gun or a soft brush to remove the leaves, insects and dust from their front surfaces. Otherwise, these objects will block the air flow, thereby reducing the cooling effect.
- › Running the A/C regularly keeps the compressor and seals well lubricated and prevents leakage. Therefore, even in the cold season when air conditioning is not required, it is necessary to run the air conditioning at least once a week for more than 10 minutes each time.
- › If the A/C system does not cool as well as before, head to the authorised service centre for maintenance.
- › Direct discharge of refrigerant into the atmosphere is harmful to the environment and the refrigerant should be recovered by trained and certified technicians using appropriate containers.

i NOTICE

About the air conditioning odour

› Source of the odour

Internal and external air exchange should be carried out for A/C as its long-term use may gather dirt which will go mouldy after a long time, resulting in odour.

A/C system

1

Operation

The A/C filter will accumulate water vapour, dust, etc. after use for a long time, resulting in odour.

Recommended measures

When the outside air is fresh, use the external circulation mode so that the air in the vehicle may maintain the good ventilation.

When the vehicle is in cooling mode, you are recommended to turn off the **【A/C】** switch first and let the blower continue running for about 1 to 2 minutes before turning off the air conditioning system. This will dry off the air conditioning evaporator and the air conditioning system to prevent mould growth and odours.

When you feel the odour is very strong, you are recommended to head to the authorised service centre for check. Clean or replace the air conditioning filter element, if necessary.

A/C vent

Front vents

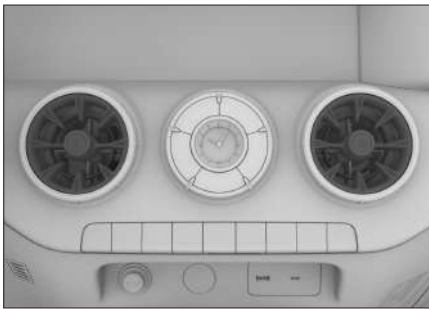

03CFE1861A3C

Rotating the knob at the center of the vent to open or close the air outlet.



Turning the slats at the center of the vent to adjust the venting direction.

Rear vents



126837FD4E40

Turning the slats at the center of the vent to adjust the venting direction.

As the direction indicated by the left-to-close marking  or right-to-close marking  to close the air vent.

Vent of storage box



446FB30D5657

Press the vent valve downwards in the storage box can open it, pull out the vent valve can close it.

After opening the valve, when the air condition is in face-blowing mode or feet and face-blowing mode, the air flow can be introduced into the storage case.

i NOTICE

The ventilation temperature can be changed depending on the working status of the air condition system.

- › When the air condition is in face-blowing mode or feet and face-blowing mode, the air flow can be introduced into the storage case. Therefore, in general, the air introduced into the storage is cold air.
- › When the air condition is heating, and switch to face-blowing mode or feet and face-blowing mode manually, the air introduced into the storage is hot air.

Mobile wireless charging

Vehicle equipment

Please note that this manual contains all the standard equipment, country-specific equipment and special equipment for this model series. Thus, some equipment or features described in this manual may not be installed onto your vehicle or are only available in some markets. For further configuration information, please refer to relevant sales information or consult with your distributor selling the vehicle to you.

Instructions

You can enable or disable the wireless charging function of your mobile through the **【Vehicle Setting】** → **【Comfort】** interface on the multimedia display screen.

- › After turning on the wireless charging function of mobile, make sure that the doors are closed, switch the power supply to ON mode or start the vehicle. Then the mobile placed in the charging area can be charged.



5883BD653E55

i NOTICE

In order to achieve a better charging effect, ensure that the charging coil of the mobile is facing downwards.

i NOTICE

- › This function is not applicable to all mobiles, but only to mobiles that have passed the "Qi" official standard certification and can be normally placed in the charging area.
- › Only one mobile can be charged at a time.
- › On bumpy roads, intermittent stopping and resuming of wireless charging may occur. If the mobile deviates from the charging area and the charging stops, move the mobile back to the chargeable area.
- › It is normal that wireless charging devices and mobiles will get hot during charging.

When the temperature is too high, the system will stop charging, and will continue charging after the temperature drops.

- › If the mobile is faulty, this may also cause it to fail to be charged. Other mobiles that meet the requirements can be used for wireless charging detection to confirm whether the mobile is faulty.

Mobile wireless charging

- › If the mobile is equipped with a protective cover or an accessory that does not support wireless charging, take out it first; otherwise, the mobile cannot be charged normally.
- › To prevent draining the battery voltage, do not use the wireless charging function for a long time when the vehicle is not started.

⚠ WARNING

- › For the sake of safety, drivers should not perform charging related operations during driving.
- › Do not place coins, keys, chip cards and other metal objects in the charging area. Otherwise, metal objects may be heated, which may lead to abnormal charging or safety accidents.

If metal foreign objects are found in the charging area during charging, do not remove them by hand to avoid scalding your fingers. You should turn off the wireless charging function immediately, and wait a few minutes before removing foreign objects.

- › If you need to use the charging area as a storage case, turn off the wireless charging function.

⚠ CAUTION

- › Do not spray any liquid at the charging area, so as to avoid the liquid seeping into the wireless charging system through the clearance of rubber mat, which may lead to system failure.
- › Do not modify the wireless charging system to avoid damage to the vehicle or accidents.

Interior equipment

Vehicle equipment

Please note that this manual contains all the standard equipment, country-specific equipment and special equipment for this model series. Thus, some equipment or features described in this manual may not be installed onto your vehicle or are only available in some markets. For further configuration information, please refer to relevant sales information or consult with your distributor selling the vehicle to you.

Sun visor

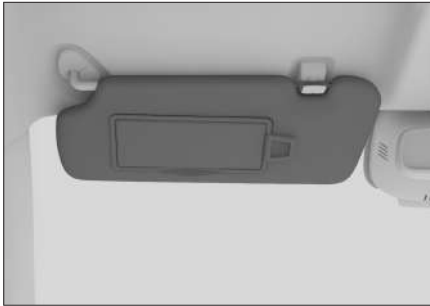

920E62AAC549

To block sunlight from straight ahead, flip down the sun visor.



1971B9BA3A27

To block sunlight coming in from the side, flip down the sun visor, unhook it and push it to the side.

Vanity mirror

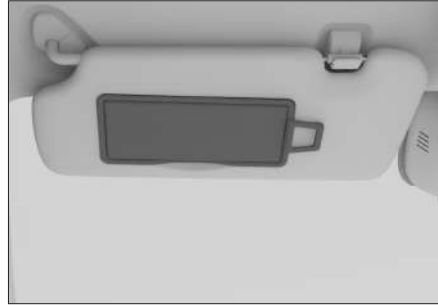

2D879B3636C3

Open the cover to use the vanity mirror set inside the sunshade.

Close the cover when not using the vanity mirror.

Storage devices

Storage box



CD20AAF3F1B5

Press the open button of the storage box to open it automatically.

Flip the storage box up until the lock is in place and then close it.

⚠ WARNING

Make sure the storage box is closed when driving. Otherwise, such items may be dislodged from the storage box and lead to an injury in the case of an accident or emergency braking.

Spectacle case

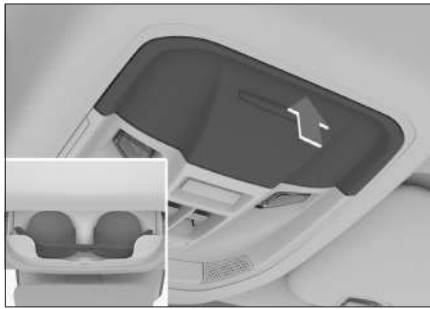

Press the spectacle case to open it. When placing glasses, fold the two mirror legs normally, with the lens facing forward and the mirror leg facing upward. Otherwise, the glasses may fall off when opening the glasses case.

⚠ WARNING

Make sure the spectacle case has been closed when driving.

i NOTICE

Certain oversized sunglasses models may not fit into this case.

Storage case

It is located in front of the front armrest



The storage case can be slid forward and backward for a certain distance. When sliding backwards, the front cup holder can be seen.

It is located in the middle of the front seat



When using the storage case, just flip up the front seat armrest.

The storage is connected with the air condition, with ventilation function.

(▷ Page 68)

Interior equipment

1

Operation

It is located near the steering wheel



A809B5F1BCF7

When in use, press the storage case then release it until the case is popped out.

This storage case is suitable for storing highway toll cards, bank cards, loose change, keys, other small items and so on. It is inconvenient to put or take other bigger items.

When not in use, press the storage case until the case is in place.

⚠ CAUTION

It is forbidden to pop the cigarette ash into the storage case. The storage is plastic part, the high-temperature ash will damage to the storage and even cause fire.

It is located in the left lower of the instrument panel



44362F676D68

When not in use, press the storage until the case is popped out automatically.

This storage case is suitable for storing smaller items such as driving license, driving booklets and so on. It is inconvenient to put or take other bigger items.

When not in use, flip the storage box up until it is locked in place and then close it.

⚠ CAUTION

It is forbidden to pour water or other liquids into the storage case. The fuse box is located in the back of the storage case, penetration of moisture will affect the use of fuses.

Front row cup holder

Slide the storage case backwards to see the front cup holder.

Interior equipment



EE1D2D7767C8

⚠ WARNING

- › When placing hot drinks, be careful to avoid burns.
 - › Only place beverage cans of suitable size and with lids in the cup holder. Do not place small or unstable beverage cans in the cup holder, or they may tip over or fall out of the cup holder, which may cause an accident or personal injury.
- Make sure the beverage cans are intact and the lids are closed; otherwise the liquid in the beverage cans may spill, with a risk of damaging the electronic equipment in the car, soiling the interior, or causing personal injury.

- › If items are not properly stored in the vehicle, they may slip or be thrown up and strike the driver and passengers. Likewise, in the event of an accident, items stored in cup holders, mobile holders and open storage spaces may accidentally move and cause personal injury, especially during emergency braking or sudden steering.

Front cup holder removal and installation

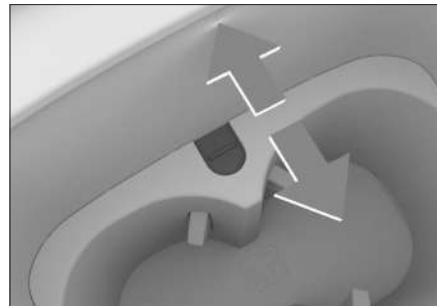

D899CF2EA7B9

Turn the cup holder fixing switch backwards to make the switch detach from the storage case wall and take out the cup holder upwards.

Put the cup holder in place along the storage case wall, and turn the cup holder fixing switch forwards to secure the cup holder.

1

Operation

Interior equipment

Rear cup holder



4F3CB3866BC8

Tilt the rear seat armrest to the lowest position to use the rear cup holder.

⚠ WARNING

- › When placing hot drinks, be careful to avoid burns.
- › Only place beverage cans of suitable size and with lids in the cup holder. Do not place small or unstable beverage cans in the cup holder, or they may tip over or fall out of the cup holder, which may cause an accident or personal injury.

Make sure the beverage cans are intact and the lids are closed, otherwise the liquid in the beverage cans may spill, with a risk of damaging the electronic equipment in the car, soiling the interior, or causing personal injury.

- › If items are not properly stored in the vehicle, they may slip or be thrown up and strike the driver and passengers. Likewise, in the event of an accident, items stored in cup holders, mobile holders and open storage spaces may accidentally move and cause personal injury, especially during emergency braking or sudden steering.

Bottle holder

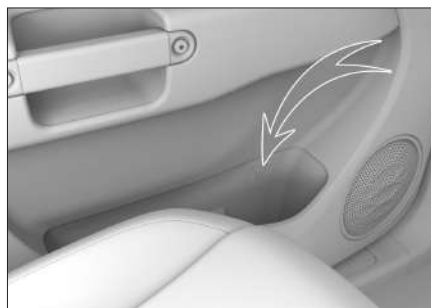

5E46FE510ACB

There is a bottle holder on the inside of each door, which is used only for placing the sealed bottle container.

⚠ WARNING

Do not place anything other than bottles inside the bottle holder. Otherwise, in the case of an accident or emergency braking, such items may be dislodged from the bottle holder and lead to an injury.

⚠ CAUTION

Make sure that the lid of the bottle is covered to avoid spilling liquid.

1

Operation

Interior equipment

Luggage hook

Located on the right side of the auxiliary instrument panel



18F0098E8BC9

When using it, press the top end of the luggage hook and release it, and the hook will gently pop open. Flip it downwards.

When not using it, flip up and press the upper part of the luggage hook to return it to its original position.

The luggage hooks can only be used to suspend lighter items, and the maximum load weight must not exceed the weight marked on the luggage hooks. Make sure all items are secured before driving.

Located on the right trim panel of the luggage area

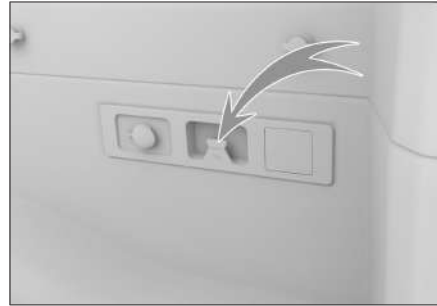

3DD64C217BF5

The luggage hooks can only be used to suspend lighter items, and the maximum load weight must not exceed the weight marked on the luggage hooks. Make sure all items are secured before driving.

Similar luggage hooks are also found on the inner trim panel of the tailgate.

Off-road dining table

Installing method

1. Remove the luggage area cover from the luggage area.

1

Operation

Interior equipment

1

Operation

2. Take out the folding table legs from the support plate under the luggage area cover and unfold them so that the four tops with the screw fasteners are facing upwards.

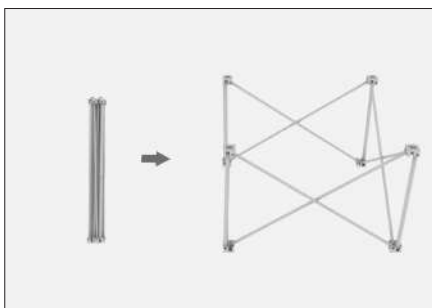

7CA3EFECE6E6

3. Attach the screw fasteners at four tops of the folding table legs to the four clamping mechanisms under the cover in turn.



BC6C62AB6AE9

4. The installed dining table is shown in the figure.



0A4DFEE2F38D

⚠ CAUTION

The table has a maximum load capacity of 60 kg and shall not be used for bearing persons or heavy objects. Otherwise, the table may be damaged or personal injury may be caused.

Removing method

1. Remove the top screw fasteners of the folding table legs from clamping mechanisms of the cover. Fold these table legs and place them back into the support plate of the luggage area.
2. Put the luggage area cover back into its original position at the luggage area.

Interior equipment

Power supply socket

USB Type-C power supply socket

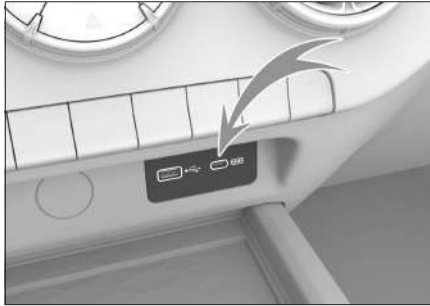

Located in front of the auxiliary instrument panel

Just use it when the power supply is set to ON mode.

This power supply can be used to charge the devices such as mobiles and tablets.

USB Type-A power supply socket



Located beside the rear A/C vent

Just open the cover to use it when the power supply is set to ON mode.

This power supply can be used to charge the devices such as mobiles and tablets.

Standby power supply

Located in front of the auxiliary

instrument panel



Just open the cover to use it when the power supply is set to ON mode.

This power supply can provide a 12 V DC power for accessories with rated power less than or equal to 120 W (10 A).

Located on the right trim plate of the luggage area



Just open the cover to use it when the power supply is set to ON mode.

This power supply can provide a 12 V DC power for accessories with rated power less than or equal to 120 W (10 A).

1

Operation

Interior equipment

220 V power supply



58192C773B8E

Located on the right trim plate of the luggage area

Just open the cover to use it when the power supply is set to ON mode.

This power supply can provide 220 V AC power supply for accessories with rated power less than or equal to 120 W.

Driving recorder power supply

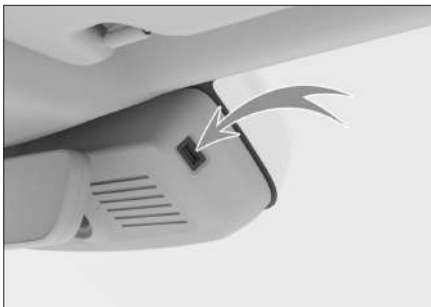

C842CC4D235B

The driving recorder power supply is located near the interior rearview mirror, as shown in the figure.

The power supply can be used when it is in the ON mode.

This power supply is designed to provide a 5 V DC power supply for driving recorders whose rated power is less than or equal to 10 W.

⚠ WARNING

For driving safety, be careful not to block the line of sight to prevent danger when installing a driving recorder.

External 12 V power supply

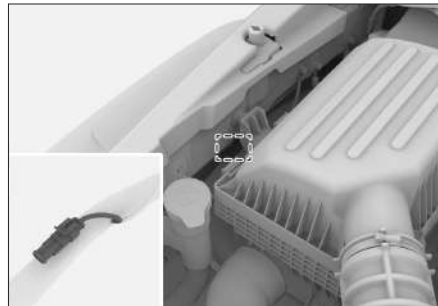

1B4FBE3EF9E9

The external power supply is located near the main body of the air filter and can provide a 12 V DC power supply with a rated power less than or equal to 300 W for external maintenance of lighting equipment, camping electricity, etc. When the power supply is in use, ensure that the external connector is normal, start the engine and press the external power supply button.

Interior equipment



E2FB56D0853A

The external power supply button is on the panel of the reading light.

⚠ WARNING

The power of the external power supply should not exceed its limited value. If other high voltage power supply is connected, fire may be caused.

Never install the spotlight which does not comply with the traffic laws and conduct other illegal acts.

⚠ WARNING

Flammable gases and heaters must be kept away from the power supply socket.

⚠ CAUTION

- › Avoid liquids such as beverages or foreign objects to enter the power supply socket. Otherwise, the faults like short circuits may be caused. If the power supply socket has a cover, close the cover when it is not in use.
- › If you use an accessory that exceeds the rated power, the vehicle fuse may be burnt out.

- › Do not connect precision devices, highly sensitive equipments or other important equipments to this power supply socket.
- › Do not use this power supply in humid and high-temperature environments.
- › Never use it in parallel or in series with any other power supply.
- › If you find any abnormal conditions (unusually high temperature, smoke, odour, etc.) during use, please stop using the power supply immediately and contact the authorised service centre for inspection and repair.
- › Never modify or repair this power supply system without authorization.
- › The external wiring harness should be waterproof and sealed.

1

Operation

2

Driving

Driving procedures.....	84	Off-road cruise control assist system.....	164
Advice on driving in harsh environments	90	Hill descent control system (HDC)	168
Advice on driving during run-in period.....	99	Driving assist system.....	169
Power supply switch	101	Emission control system.....	173
Starting and shutting down the vehicle	103	Virtual instrument panel	177
Parking brake	105	Instrument indicator lights .	182
Automatic transmission	108	Power management system	191
Power steering mode.....	114		
All-terrain control system....	115		
Differential lock.....	121		
Intelligent start-stop system	125		
Parking assist system.....	128		
Tyre pressure monitoring system	136		
Cruise control assist system	138		
Intelligent driving assist system	147		

Driving procedures

Vehicle equipment

Please note that this manual contains all the standard equipment, country-specific equipment and special equipment for this model series. Thus, some equipment or features described in this manual may not be installed onto your vehicle or are only available in some markets. For further configuration information, please refer to relevant sales information or consult with your distributor selling the vehicle to you.

Before driving

Removing debris

Remove the snow and fallen leaves, etc. before driving.

Checking vehicle conditions

Check tyres, fluid, lights and body appearance before driving to ensure your safe and pleasant driving.

If your vehicle requires maintenance or repair, get in touch with the authorised service centre in a timely manner.

Confirming vehicle doors and bonnet status

Before driving, confirm all vehicle doors are closed. If a vehicle door has not been closed properly, it may open unexpectedly during the driving and cause an accident.

Before driving, if you have opened the bonnet, confirm that the bonnet has been locked down. If the bonnet has not been locked properly, it may open during driving and cause an accident.

Placing objects in-vehicle

On the instrument panel

Do not place any item on the instrument panel. The items placed on the instrument panel may not only obstruct the driver's view, but also affect the starting off and safe driving, which may lead to accidents.

The driver's feet well

Do not place any items at the feet well of the driver. Items placed at the driver's feet well may be trapped under pedals, causing the driver to lose control of the vehicle, which leads to an accident.

If you want to use a floor mat, choose a suitable floor mat. If the selected floor mat shape and its layout position are inappropriate or if the floor mat is double stacked, pedal performance may be affected, which could lead to problems in starting the vehicle, braking, or difficulties in changing gear, and could result in an accident.

Under the seat

Do not place any items under the seat. Items placed under the seat will make it difficult to adjust the seat position or fasten the seat, which can easily lead to an accident.

Seat backrest

Do not place cushions and other items between the seat backrest and the back of the human body. Otherwise, the correct driving posture will be affected; besides, in the event of a vehicle collision, seat belts and head restraints will not function properly and provide full protection, and even serious life-threatening injuries will occur.

On the window glass

Do not attach decorative items like vacuum suction cups to window glass.

Vacuum suction cups can act as a lens, leading to a higher risk of fires.

Precautions for driving

No speeding

The vehicle should not exceed the speed indicated by speed limit signs or mark lines.

No overloading

Overloaded driving is dangerous.

Do not carry passengers or goods more than what is on the indicated maximum limit. Do not carry passengers in the luggage area or the luggage compartment.

No fatigue driving

Fatigue driving is extremely dangerous as the judgement, view and attention of the driver in fatigue state will drop substantially. It can easily cause a serious accident.

Not shutting down the engine

The brake booster and power steering system will not function if the engine does not work, which may lead to deterioration of braking efficiency, and cause severe accidents.

No turning the steering wheel full-lock for a long time

Turning the steering wheel full-lock for a long time may reduce the power assist effect of the steering system and you may feel heavier when turning the steering wheel.

No applying the brake for a long time

While driving, do not continuously step on the brake pedal or apply the parking brake. Otherwise it may lead to premature wear-and-tear in the brake pad or overheating in the brake, thereby affecting the braking efficiency and possibly leading to accidents.

Brake emitting a warning sound

The disc brake will emit a warning sound when the brake pad wears and needs to be replaced.

If you hear a rattling sound while braking, do not continue driving. Otherwise, this will severely wear the brake disk, damage the brake parts and affect the braking efficiency or even lead to an accident.

Driving procedures

2

Driving

Flat tyre

Do not continue to drive the vehicle with a flat tyre. Driving with a flat tyre is extremely dangerous and can easily cause a serious accident. In addition, tyres, wheels, suspension and vehicle body will be damaged. At this moment, replace the tyre immediately.

When any of the following situations occurs, confirm whether the vehicle tyre is punctured or flat:

- › The steering wheel shakes.
- › The vehicle vibrates abnormally.
- › The vehicle is leaning at an abnormal angle.

If a tyre is flat or punctured during driving, hold the steering wheel firmly and gently step on the brake pedal to slow down. Emergency braking or turning the steering wheel sharply may lead the vehicle to go out of control.

A strong impact on chassis, tyres, and wheels of the vehicle

When the chassis, tyres, and wheels of the vehicle suffer a strong impact, stop the vehicle immediately in a safe spot and inspect the vehicle. Check for leakage in brake fluid and fuel, and for deformation or damage to suspension, tyres, wheels, drive system, etc. If you find signs of leakage or damage, do not continue to drive the vehicle. Failure to adhere to the advice may lead to accidents.

Driving downhill

Using engine assist braking

If you continuously depress the brake pedal while driving downhill, the brake may overheat, thereby compromising the braking efficiency and making the occurrence of accidents more likely.

No shutting down the engine or coasting in N gear position

If the engine stops when you go downhill, the brake booster and power steering system will not work, resulting in poor braking efficiency. Thus, the steering wheel will be heavy to operate, and accidents are more likely to occur.

Driving on uneven road surfaces

When stopping the vehicle on a curb or on a road surface with a height difference, make sure that the tyres are not crushed and deformed by the curb or other obstacles.

When the vehicle must pass a curb, a speed bump or a similar obstacle, you should try to slow down along the vertical angle of the obstacle. Failure to do so may result in damage to the tyre (especially to the side wall of the tyre).

Driving in the following road conditions may cause damage to the bumper. Slow down and drive carefully.

- › Road sections with steps such as parking lot entrances and exits;
- › Steep slopes such as sharp turns in multi-story parking lots;

- › Potholes and rutted roads;
- › Sections of road where there are pot-holes;
- › Driving from a flat section to a ramp, or from a ramp to a flat section;
- › Parking on a road with speed bumps or along a curb.

Driving on slippery road surfaces, such as wet, snowy or icy road surfaces

Emergency braking, sudden acceleration, or turning steering wheel sharply on slippery road surfaces may cause vehicle tyres to skid and the vehicle to go out of control, thereby causing an accident.

In cold weather, you should slow down when driving in areas that are prone to freezing, such as bridges and shady areas.

Driving on flooded roads

Be careful while driving on flooded roads.

Driving on flooded roads may lead to engine shutting down, short circuit of electrical components or engine damage, all of which may cause a major accident.

While you drive on flooded roads, the brake pads will become wet and the braking efficiency will be reduced, which can easily lead to accidents. Step gently and repeatedly on the brake pedal in order to warm up the brake until full brake performance has been recovered.

Precautions for passengers

Moving within the vehicle is forbidden

It is forbidden for the passenger to leave his or her seat, or to move around inside the vehicle. Otherwise, during emergency braking, the passenger's body or head, etc., may suffer injurious impact.

Do not extend your hands or head outside the vehicle window or sunroof

If you stretch your hands or head out of the vehicle, it is prone to hitting against the window frame when braking the vehicle in emergency or closing the window. In this case, it may cause serious injury or even death.

Do not carry child passengers on your lap

When riding as a passenger, do not carry infant or child passengers on your lap even if you are already wearing a seat belt. Further, do not surround or enclose the infant or child using any part of the seat belt; this may cause grievous injury or even death during collisions or emergency braking.

Driving procedures

2

Driving

Child passengers must not be allowed to operate equipment such as vehicle doors, vehicle windows and the sunroof

If child passengers are allowed to operate doors, windows and sunroof, they are at risk of clipping their hands, heads, necks, etc., in the operation, which will result in a serious personal injury.

If the vehicle door is opened during the driving, children, if not restrained correctly, could fall out of the vehicle, consequently causing serious injuries and even death.

Please use a child safety lock and a window lock switch to prevent children from accidents because of an incorrect operation.

Parking the vehicle

Do not park the vehicle close to flammable materials

Do not park your vehicle near flammable materials such as areas with plenty of grass/hay or scrap paper. Fires may be triggered by contact between the hot exhaust pipe and flammable materials.

If there is wood or plywood in the rear of the vehicle, keep the parking distance. If the distance is too close, it may cause fire.

Do not run the vehicle for a long time in poorly ventilated places

Allowing the engine to idle for extended periods in poorly ventilated areas such as garages can cause exhaust gas build-up, thereby causing severe injury or even death by carbon monoxide poisoning.

Economic driving

Predictable driving

Maintain a proper distance with the front running vehicle and avoid unnecessary acceleration and braking. A stable vehicle speed can reduce fuel consumption.

Reducing idling operation

If you need to stop for a long time when you are at a traffic light junction, a railway crossing or a traffic jam, you shall turn off the engine to reduce unnecessary fuel consumption.

Avoiding unnecessary weight

The loaded and overloaded driving of the vehicle will increase fuel consumption. Before driving, remove unnecessary items from the vehicle.

Checking tyre pressure periodically

Too small tyre pressure will increase the rolling resistance, thus increasing fuel consumption and tyre wear.

Regular maintenance

Regular maintenance ensures a longer service life and the best economy of your vehicle.

Turning off temporarily unnecessary electrical components

Electrical components such as A/C and heating device require a lot of energy and consume fuel, so turn off these electrical components when they are not used.

Closing windows and sunroof

Opening the windows or sunroof increases the windage, thereby increasing fuel consumption, so turn them off when you do not need them.

Coasting

The accelerator pedal shall be released when you approach the red traffic light or go down a large slope, allowing the vehicle to take advantage of coasting.

Advice on driving in harsh environments

2

Driving

Vehicle equipment

Please note that this manual contains all the standard equipment, country-specific equipment and special equipment for this model series. Thus, some equipment or features described in this manual may not be installed onto your vehicle or are only available in some markets. For further configuration information, please refer to relevant sales information or consult with your distributor selling the vehicle to you.

Driving in foggy weather

Turn on the fog lamps

While driving in fog, you should turn on the fog lamps.

Sound horn to warn pedestrians and vehicles

If you hear the horn of other vehicles, respond immediately by honking your horn to indicate your position.

Drive at low speed and look out for safety

When driving in foggy weather, try to travel at a low speed and keep a safe distance from the vehicle ahead.

Do not wipe fog on the glass during vehicle running

Due to large temperature difference inside and outside the cab, mist may condensates on the inside surface of the windscreen that can affect driver's sight. In this case, you can use the A/C defrosting function or open the vehicle windows a little to have the same air temperature inside and outside the vehicle. This will prevent condensation to form on the inside surface of windscreen.

If you wish to wipe away the condensation on the windscreen glass, please do so only after bringing the vehicle to a stop. Never try to do so while driving the vehicle.

Driving in the rain

Please drive carefully on slippery road surfaces

As poor vision, foggy windscreen and slippery roads are likely to occur when running on rainy days, please drive carefully.

When performing emergency braking, steering and accelerating on a slippery road, tyres may slip, making it difficult to control the vehicle, which may lead to an accident.

While driving in rain, water film can form between the tyre and the ground. At this time the tyre can easily lose its grip, so for safe driving you should slow down.

Advice on driving in harsh environments

WARNING

Try to avoid driving in a heavy rain or a rainstorm.

Fording drive

The maximum allowable static fording depth of the vehicle is 700 mm. When the vehicle is driving in flowing water, the fording depth should be lower.

In fording drive, pay attention to the waves preceding vehicle and the oncoming vehicle made. This will cause the fording depth exceeds maximum permissible depth.

When the fording depth is within 50 to 100 mm, the vehicle should be no more than 45 km/h.

When the fording depth is within 100 to 350 mm, the vehicle should be no more than 20 km/h.

When the fording depth exceeds 350 mm, drive at a low speed not exceeding 10 km/h. Do not stop or shift gears.

Precautions for fording drive

- › Before fording drive, confirm the water depth of the road area. If there is more water or the water depth is unknown, drive to take a detour and do not go through a direct course.
- › Analyse the road conditions and do not drive into an unfamiliar area where there may be hidden obstacles such as ditches or manholes.

- › Do not attempt to restart the vehicle if it is accidentally stalled during fording. Otherwise, serious engine damage may be caused.

Check and maintenance after fording

Promptly do the following after safely driving through water:

- › Test the horn.
- › Test all the vehicle lights.
- › Step on the brake pedal lightly several times and check whether all brake functions are working.
- › Avoid stopping immediately and continue driving for 5 to 10 minutes to prevent rusting of parts such as the turbocharger and actuator tie rod. During driving, you can accelerate the vehicle by slightly depressing the accelerator pedal to confirm whether there is a persistent noise (a sound from metal parts rubbing against each other).
- › Go to the authorised service centre as soon as possible for routine inspection. During fording drive, water may enter the components and parts of transmission system and dilute lubricant, which may lead to system malfunctions.

CAUTION

- › Fording drive cannot be used as a part of routine driving.

Advice on driving in harsh environments

- › You should be careful during fording drive.
If possible, avoid fording drive.
Choose safe and reliable way to drive if necessary.
- › Fording drive may damage the engine and electrical components and so on.
- › Do not drive through salty waters, beaches or salt water areas as salt may cause vehicle corrosion. If you drive through the above areas, immediately use fresh water to flush all parts that have been in contact with salt water.

Driving during the hot seasons

Hot weather and high temperature in summer are bad for the normal vehicle running and the health of driver. To ensure driving safety, the driver shall pay attention to the following items:

To prevent the engine from overheating

The engine is prone to overheating in the hot season due to higher ambient temperature. Therefore, please step up the inspection and maintenance of the engine cooling system, and remove debris embedded in the radiator chips.

Preventing flat tyre

As air pressure in the vehicle tyre rises with temperature increase, flat tyre is likely to occur in case of hot weather and high temperature in hot season.

If you experience a flat tyre in the course of the drive, hold the steering wheel securely, step gently on the brake pedal to decelerate, and avoid actions such as emergency braking or sudden steering. Failure to adhere to the advice may cause the vehicle to go out of control.

Preventing sunstroke

Strong sunlight and high temperature in hot season easily lead to sunstroke.

Keep the driving room well ventilated and prohibit fatigue driving.

WARNING

Never leave a child in the vehicle unattended.

- › Leaving children alone in the vehicle during hot seasons can easily cause heat stroke, dehydration, personal injury or even death.
- › If the child, left alone in the vehicle, plays with matches, lighters other items, it is easy to cause vehicle fire accidents.

Advice on driving in harsh environments

⚠ CAUTION

When parking the vehicle, do not leave items such as lighters, spray can, soft drink cans, spectacles, etc., inside the vehicle.

- › As temperatures inside the vehicle can get very high, a leakage of gas from the lighter, spray cans or cracks in these containers can lead to fire.
- › Should a soft drink can burst inside the vehicle, its contents may splash onto electrical components and cause short circuit.
- › As temperatures inside the vehicle can get very high, it is easy to make resin lens or glasses deformation, resulting in crack.

Driving in cold season

Winter tyre

In cold season when the temperature is low, due to the special characteristics of the normal tyres (tyre width, rubber composition and pattern type, etc.), the elasticity of tyres decreases, further weakening the traction and braking force. At the same time, the tyre noise will be increased. In severe cases, it can even lead to serious cracks, abnormal wear and tear and other permanent damage of normal tyres. Therefore, use winter tyres when the temperature is lower than 7°C. Winter tyres can not only greatly improve the vehicle control stability, but also improve the vehicle braking response and shorten the braking distance.

i NOTICE

Although all-weather tyres with M + S markings are better for cold season, they fail to achieve the performance of winter tyres. Therefore, it is still necessary to use winter tyres for driving on snowy or icy roads.

⚠ WARNING

Although winter tyres can improve the vehicle driving performance in winter, do not drive at risk situation, and still keep cautious!

Advice on driving in harsh environments

2

Driving

- › Be sure to adjust your speed and driving style based on visibility, weather conditions, road and traffic conditions.
- › Do not exceed the speed limit and load rating indicated on the installed winter tyres when driving.

CAUTION

When the pattern of winter tyres is severely worn, their applicability to cold season will be largely lost. If winter tyres have aged, their applicability to cold season will largely be lost even though the tyre pattern wear is insignificant. Consult the dealer for specific replacement standards of winter tyres.

Instructions for using winter tyres

- › You must comply with the relevant laws and regulations of the country where the winter tyres are used.
- › The four wheels must have winter tyres installed at the same time.
- › Always use winter tyres having the same size as the normal tyre.
- › Winter tyres having the same model, size (rolling circumference) and type must be used.
- › Winter tyres can only be used during the cold season.

- › Be sure to comply with the allowable maximum limits for winter tyres (such as maximum speed, maximum load, etc.). Otherwise, tyres may be damaged, causing traffic accidents.
- › Do not reverse the rotation direction of the tyres.

Snow chains

The use of snow chains depends on the current standards in specific countries or regions, and the installation of snow chains must comply with local regulations.

Install snow chains on the drive wheels only. Do not install snow chains on only one tyre. Install snow chains following the instructions provided by the snow chain manufacturer and tighten them as tightly as possible.

CAUTION

Observe the following precautions when installing snow chains:

- › Improper size or installation of snow chains will damage the vehicle brake pipeline, the suspension, the body and tyres, etc. Choose suitable snow chains and ensure that they are properly installed.
- › Install snow chains in a safe place. Turn on the hazard warning lights, and set the warning triangle behind the vehicle.

Advice on driving in harsh environments

- › Shut down the engine and apply the parking brake before installing the snow chains.
- › Do not install snow chains on emergency wheels or small size spare tyres.
- › Do not install snow chains when the tyre pressure is low.
- › Do not damage the aluminium alloy wheel rim when using snow chains.

⚠ CAUTION

Observe the following precautions when driving with snow chains:

- › After installing snow chains, the driving speed shall not exceed 40 km/h or the maximum speed recommended by the snow chain manufacturer, whichever is lower.
- › After installing snow chains, always check that the snow chains are properly installed after travelling 0.5 to 1.0 kilometres to ensure safety. Retighten or reinstall the snow chains if they are loose.
- › After installing snow chains, the vehicle control may be adversely affected. Operations such as sudden acceleration, sharp turns and emergency braking should be avoided as much as possible; otherwise accidents may occur.

- › When driving, if you hear the snow chains knocking on the vehicle body or chassis, stop the vehicle and retighten the snow chains. If you can still hear the sound, slow down until the sound disappears.
- › Avoid driving on bumpy road surfaces or over potholes.
- › Slow down before entering the curve, so that you can control the vehicle.
- › Remove the snow chains when driving on road surfaces without snow, or they may affect driving performance and severely damage tyres.
- › Turn off the electronic stability control, otherwise, unnecessary brake or warning may be triggered.

⚠ WARNING

When parking on snowy roads, shut down the engine.

- › If the engine is running with snow accumulated around it, exhaust gas may seep into the vehicle, causing severe injury or even death by carbon monoxide poisoning.
- › When you feel that exhaust gas comes into the vehicle, you can take the following measures:
Drive the vehicle to a ventilated area and lower all the windows.

Advice on driving in harsh environments

Set the A/C to the external circulation mode, adjust the airflow to the maximum, and introduce fresh air from the outside into the vehicle.

Off-road driving alerts

- › Off-road driving has a lot of fun, but that doesn't mean drivers can take it lightly. At all times drivers shall take the situations they face seriously and carefully, and not take risks in dangerous areas. Otherwise, it can be very dangerous if things go wrong.
- › When you drive off-road, safety is of paramount importance and shall be our first priority at all times. Before driving, ensure that all occupants wear their seat belts and that all items are securely fastened to prevent danger from moving objects in the vehicle while it is in motion.
- › When driving off-road, do not grasp the spokes of the steering wheel as the violent bumps could twist the wheel and injure your hands.
- › If you are going to drive through a river, check the depth of the water and the solidity of the bottom of the riverbed first, drive slowly and avoid deep water area. If necessary, take the necessary safety measures to ensure that the engine or other components are not damaged by water immersion.
- › After driving over grass, mud, gravel, sand or river, check whether there are weeds, branches, gravel, sand etc. at the bottom of the body. Remove such debris. If the vehicle continues running with such debris, the vehicle may malfunction or a fire may occur.
- › After driving over sand, mud, water or snow, check whether the brake functions normally. The mud and sand adhering to the brake disc can affect the braking effect and can damage brake system components.
- › If you drive in dusty conditions or on sand, the air filter will be severely affected, so take at least one spare filter with you. For driving in dusty conditions, the air filter shall be checked daily. Check the air filter immediately after driving on sand. If any abnormal condition is found during the inspection, duly clean or replace the air filter. Otherwise, the engine may be damaged.
- › Higher ground clearance allows the driver to have better vision, detect road conditions in time and adjust the driving style according to the specific terrain conditions.

Advice on driving in harsh environments

- › Before returning to the highway after off-road driving, clean the tyres to remove foreign objects such as mud and small stones. Otherwise, a large amount of mud and stones on the tyres may cause serious damage to windscreen and other components when you drive at a high speed on the highway. Also, check whether the tyres are in good condition and check the tyre tread and sides for signs of breakage to ensure that there is no damage to the tyres that could cause a blow-out due to high speed driving. Also, remove mud and dust from the lights, windows, windscreen and license plate.

⚠ WARNING

- › Due to high ground clearance and high centre of gravity, avoid high speed driving, sudden start, sharp turn, emergency braking or abrupt operation. Otherwise, the vehicle may lose control or overturn due to incorrect operation. Caution shall also be exercised in driving especially when goods are loaded on the roof luggage rack, as loading goods will raise the vehicle's centre of gravity again.

- › Slow down in the event of a crosswind. The vehicle with higher ground clearance and centre of gravity is more susceptible to a crosswind, and lowering the speed will give you better control of the vehicle.
- › When driving on rough roads, do not drive too fast, jump or hit objects; otherwise, the vehicle may lose control or overturn, resulting in serious injury or death, and thus seriously damaging the suspension and chassis.
- › When the vehicle needs to be driven on a steep slope, it is best to drive straight up or down the steep slope rather than driving sideways on it. Driving sideways on a steep slope may lead to a rollover due to the high centre of gravity.

Advice on inspection and maintenance

Once you drive off-road in poor road conditions such as sand (dusty roads), mud, water and salt roads, check the following items duly and carry out maintenance or repairs as needed:

- › Check the horn.
- › Check all vehicle lamps.
- › Check the bottom of the vehicle for oil and fluid leakage.

Advice on driving in harsh environments

2

Driving

- › Check whether all components on the bottom of the vehicle are in good conditions. Duly remove hay and other debris to eliminate potential hazards that could cause breakdowns and fires.
- › Check the differential, transmission and transfer case for water or mud.
- › Check the air filter and related lines for water.
- › Check the air filter for sand and clean it in time.
- › Check whether there is mud or debris adhering to the radiator, condenser, oil cooler, intercooler and fan, and clean them in time.
- › Check whether there is water or mud in the generator.
- › Check whether the tyre pressure is normal and whether there are cracks or damage on tyre treads and sides.
- › Step on the brake pedal a few times consecutively, and check whether brake performance has been compromised.

Advice on driving during run-in period

Vehicle equipment

Please note that this manual contains all the standard equipment, country-specific equipment and special equipment for this model series. Thus, some equipment or features described in this manual may not be installed onto your vehicle or are only available in some markets. For further configuration information, please refer to relevant sales information or consult with your distributor selling the vehicle to you.

Tyres

Take extra care in the first 500 km when driving with a set of new tyres.

New tyres do not offer optimal grip until they have been broken-in.

Friction lining of brake pad

New friction lining of brake hardly achieves optimal braking effect within first 400 km vehicle running.

New friction lining of brake must also be run-in to achieve the best friction performance. If you feel that the braking force of the vehicle is insufficient, you can step on the brake pedal to increase the braking force.

During the run-in period, avoid applying extra load on the brake. For example, emergency braking, especially emergency braking at high speed and while running on slope.

⚠ CAUTION

- › The friction linings and brake disk may wear to different degrees depending on the using condition and the driving method.
- › Due to the vehicle speed, braking force and environmental conditions (such as temperature and humidity), there may be noise when braking, which is normal.

Engine

To prolong the use life of the engine, the user must perform a break-in process beginning with zero load and then incrementally increasing load with a new engine or an engine that has just undergone major repair. Please observe the precautions listed below:

During the first 300 km:

Avoid emergency braking.

During the first 1,000 km:

- › Avoid driving at high speed.
- › Do not depress the accelerator pedal to the end to avoid high-speed engine running.
- › do not drive at a constant speed for a long time, and change the speed constantly.
- › Don't drag the trailer or towing other vehicles.

Advice on driving during run-in period

From the 1000 km to 1,500 km:

Raise the vehicle speed gradually on the premise of safety.

CAUTION

During the break-in period, pay attention to the operating conditions of each engine system. If there is a breakdown or an abnormal occurrence, deal with it immediately and continue the break-in afterwards.

2

Driving

Power supply switch

Vehicle equipment

Please note that this manual contains all the standard equipment, country-specific equipment and special equipment for this model series. Thus, some equipment or features described in this manual may not be installed onto your vehicle or are only available in some markets. For further configuration information, please refer to relevant sales information or consult with your distributor selling the vehicle to you.

Push-button type

Mode switching

When carrying the smart key, directly press the power supply switch to switch between the power supply modes.



08C19E66B97A

No.	Mode	Effect
1	OFF	Electrical components are in the non-working state.
2	ON	All electrical components can be used.

i NOTICE

When the smart key is carried, depress the brake pedal with the shift lever in the gear P. The vehicle can be started by pressing the power switch regardless of the mode of the power supply.

! WARNING

Do not switch power supply modes while driving.

! CAUTION

- › Do not place the smart key on the instrument panel, on the ground, on the instrument cluster, in the storage box or in the luggage area. Otherwise, the power supply mode cannot be switched.
- › When the engine is not running, do not keep the power supply in the ON mode for an extended period of time to prevent loss of battery power.
- › When you leave vehicle, switch the power supply to the OFF mode and carry the key with you.

Power supply switch

Failing to unlock the ESCL

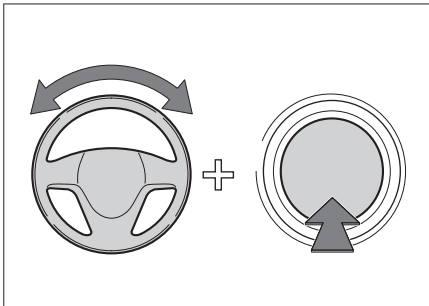

C76883D1FB9A

2

Driving

If the multi-information display indicates that ESCL unlock has failed when the power supply mode is changed or the engine is started, gently turn the steering wheel to the right and left and press the power supply switch as well to unlock it.

Starting and shutting down the vehicle

Vehicle equipment

Please note that this manual contains all the standard equipment, country-specific equipment and special equipment for this model series. Thus, some equipment or features described in this manual may not be installed onto your vehicle or are only available in some markets. For further configuration information, please refer to relevant sales information or consult with your distributor selling the vehicle to you.

Starting the vehicle

Normal starting

1. Carry the smart key with you.
2. Adjust the seat position and take correct driving posture.
3. Confirm that the parking brake has been applied.
4. Confirm that the P gear position is engaged.
5. Step on the brake pedal.
6. Press the power supply switch to start the vehicle.

Emergency starting



If the prompt "Check whether the key is in the vehicle" is shown (such as power loss of the smart key, serious damage to the door guard or the rear bumper and other situations), place the smart key above the sign  in the cup holder to perform the normal start operation of the vehicle, and then the vehicle can be started. If the vehicle cannot be started, contact the authorised service centre immediately.

WARNING

- › Be sure to sit on the driver' seat before starting the vehicle. Failure to do so may lead to accident, serious injuries or even death.
- › Do not step on the accelerator pedal under any circumstances when starting the vehicle.
- › Always start the vehicle even if you need to move the vehicle slightly. Otherwise, an accident may occur.

Starting and shutting down the vehicle

2

Driving

i NOTICE

- › Do not allow the cold engine to run at a high speed or a high load.
- › Try to avoid the engine from idling for a long time.
- › If the engine has starting problems or stops frequently, contact the authorised service centre for assistance immediately.

Shutting down the vehicle

Normal shutdown

1. After the vehicle is stopped steadily, switch to the gear P.
2. Press the power supply switch and set the power supply to OFF mode to shut down the vehicle.

Emergency shutdown

During driving (at a speed greater than 5 km/h), in the case of an emergency, for example, failure to stop in a normal way, you can shut down the engine through any of the following operations:

- › Press and hold the power supply switch for more than 2 seconds.
- › Press the power supply switch for 3 consecutive times within 2 seconds.

! WARNING

- › Shutting down the engine while driving may cause a collision or major personal injury.

- › Do not forcibly shut down the engine while driving in non-emergency situations.

When the engine is forcibly shut down, the brake and steering wheel power assist will be lost, and as a result, it is more laborious to step on the brake pedal and the steering wheel is heavier. Therefore, before shutting down the engine, please slow down as far as possible.

! WARNING

Do not touch high-temperature components such as the engine, exhaust pipe, and radiator immediately after shutting down the engine. Otherwise, you may be burned.

i NOTICE

After the engine has been running at a high speed or high load for a long time, it is recommended to let the engine idle for a short time or drive at a low speed for a certain distance before shutting down the engine.

Vehicle equipment

Please note that this manual contains all the standard equipment, country-specific equipment and special equipment for this model series. Thus, some equipment or features described in this manual may not be installed onto your vehicle or are only available in some markets. For further configuration information, please refer to relevant sales information or consult with your distributor selling the vehicle to you.

Tips for safety

⚠ WARNING

- › Parking on a slope steeper than the prescribed limit may cause an accident. Please drive safely and avoid risky parking situations.
- › If the slope is too steep, use of the parking brake system will not be able to stop your vehicle completely. In this case, step on the brake pedal to prevent the vehicle from rolling.

Electronic parking brake

Applying the parking brake



BF6CD6E571E2

- › When the vehicle is stationary and the power supply is switched to OFF mode, the electronic parking brake (EPB) will be applied automatically. At this point, the parking brake indicator light[Ⓢ] on the instrument cluster turns on.
- › If the parking brake is not required, press and hold the EPB switch while switching the power supply to OFF mode.
- › After the vehicle is stationary, pull up the EPB switch to apply the parking brake. At this point, the parking brake indicator light[Ⓢ] on the instrument cluster turns on.

Emergency braking

In case of emergency, pull up the EPB switch and hold it, and then use the EPB system to brake the vehicle.

Emergency braking can be cancelled as long as the EPB switch is released or the accelerator pedal is stepped on.

Parking brake

⚠ WARNING

The emergency braking function can only be used in the event of an emergency (e.g. the brake pedal is blocked).

Releasing the parking brake



When the power supply is in ON mode, step on the brake pedal and press the EPB switch to release the parking brake. At this time, the parking brake indicator light (Ⓢ) on the instrument cluster turns off.

i NOTICE

If the vehicle is powered off abnormally, the parking brake fault warning light (Ⓢ) on the instrument cluster turns on after the vehicle is powered on again. In this case, the system needs to self-learn. Pull up the EPB switch first, then depress the brake pedal and press the EPB switch to release the EPB normally.

AVH function



Auto vehicle hold (AVH) eliminates the need for the driver to step on the brake pedal for extended periods or apply the electronic parking brake frequently when the vehicle is on a slope, meets red traffic lights or stops and goes. It allows the driver to drive more comfortably and reduces the risk of vehicle rolling.

After the driver side door is closed, the driver's seat belt is fastened, and the vehicle is started, press the AVH switch to turn on or off the AVH function.

Instructions

1. Turn on the AVH function. At this point, the AVH function is ready, and the AVH indicator light (yellow) (Ⓢ) on the instrument cluster turns on.
2. Depress the brake pedal to stop the vehicle. The vehicle will automatically apply the parking braking. At this time, the AVH function is in operation, and the AVH indicator light (green) (Ⓢ) on the instrument cluster turns on.

3. When the shift lever is placed in gear D, M or R, depress the accelerator pedal and the parking brake is automatically released.

If the accelerator pedal is not depressed for a long time, the AVH function will be deactivated, and the vehicle will automatically switch to electronic parking mode, thus applying the braking force.

The following conditions will deactivate the AVH function forcedly:

- › The driver's seat belt is released.
- › The driver side door is opened.
- › The power supply mode is switched to OFF.
- › The AVH function has been working for more than 3 minutes.

CAUTION

In the case of automatic vehicle washing, towing, etc., turn off the AVH function.

Automatic drive-off function

With the parking brake applied to the vehicle, the parking brake is automatically released when the driver fastens the seat belt, depresses the accelerator pedal and the system detects the driver's intention to depart.

On a slope, more traction is required to avoid rolling.

Automatic transmission

Vehicle equipment

Please note that this manual contains all the standard equipment, country-specific equipment and special equipment for this model series. Thus, some equipment or features described in this manual may not be installed onto your vehicle or are only available in some markets. For further configuration information, please refer to relevant sales information or consult with your distributor selling the vehicle to you.

WARNING

- › When stopping the vehicle temporarily in the N gear position, be sure to apply parking brake or depress the brake pedal. Otherwise, the vehicle may roll away and cause an accident.
- › Vehicles are prohibited from coasting with the N gear position engaged; otherwise, there is a risk of accidents.

2

Driving

Introduction to gear positions

Park (P) gear position

The P gear position is used to assist in parking the vehicle. When the P gear position is engaged, the transmission is mechanically locked to prevent the vehicle from rolling.

Reverse (R) gear position

The R gear position is used for reversing.

Neutral (N) gear position

The N gear position is an unpowered gear position, and the transmission system is in a state of not transmitting power when this gear position is engaged.

Automatic mode (D)

The D gear position is recommended for normal driving.

When the D gear position is engaged, the transmission can automatically adjust to the appropriate gear position based on the vehicle speed and the required acceleration, to achieve the best economy.

Manual mode (M)

The M gear position is recommended for speeding up and overtaking or driving uphill and downhill.

Lower gear positions of M gear position are recommended for bumpy road, ramp and the like.

Automatic transmission

Gear shifting method

After the engine is started, normal gear shifting operations can be performed. The brake pedal should be depressed all the time before the vehicle starts off; otherwise, the vehicle will automatically move when the shift lever is in the D gear position.

⚠ WARNING

In order to avoid the damage to the vehicle or accidents, the vehicle must be completely stopped before the gear position is shifted.

i NOTICE

When the shift is completed, confirm that the correct gear position is engaged.

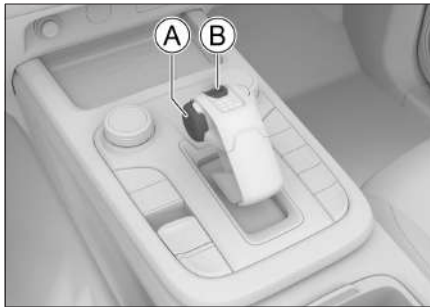

B2699E3CC212

- Ⓐ Unlock button
- Ⓑ Parking gear button

Engaging the P gear position

When the vehicle is stationary, press the parking gear button.

i NOTICE

Under the following conditions, the vehicle will automatically switch to the P gear position.

- › The vehicle is stationary and the power supply is set to OFF mode.
- › The vehicle is stationary, the driver does not fasten his/her seat belt and not depress the accelerator or brake pedal, and the driver side door is opened.

Engaging the D, R, N or M gear position



065830D08348

Move the shift lever in the direction required, and release the shift lever to return it to the neutral position automatically.

For disengagement of P gear position or engagement of R gear position, you need to depress the brake pedal and press the unlock button. For engagement of D gear position, you need to depress the brake pedal.

Automatic transmission

After engaging the D gear position, you can push the lever backwards into the M gear position and push it backwards again to move the lever back to the D gear position.

The engaged gear position will be shown on the lever and the instrument multi-information display.

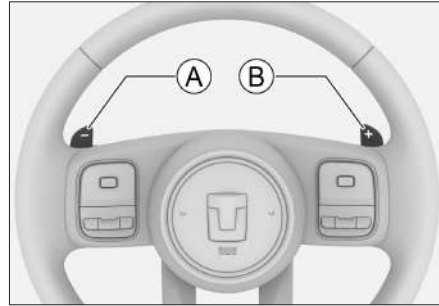

6CC1101BCF1F

Ⓐ Downshift paddle

Ⓑ Upshift paddle

Because of a paddle shifter, you can complete the upshift or downshift without taking your hands off the steering wheel.

When driving in the manual mode, you can upshift or downshift manually by toggling the shift paddle on the steering wheel.

When driving in the automatic mode, you can temporarily activate the manual mode by toggling the shift paddle on the steering wheel. In this case, you can upshift or downshift manually by pushing the paddle shifter.

When driving in temporary manual mode, you can switch from the manual mode to the automatic mode by toggling the upshift paddle for a long time.

2

Driving

⚠ WARNING

If a transmission-related error message appears on the instrument cluster, the transmission may enter the emergency operation mode. At this point, you can only shift to a specific gear or simply cannot shift, and the engine may stall. Stop at a safe place as soon as possible and contact the authorised service centre.

Gear shifting method in manual mode

ⓘ NOTICE

In manual mode, if the engine speed is too high or too low, the transmission will automatically shift to a proper gear position to protect the engine.

Automatic transmission

Unlocking P gear position in an emergency

If the transmission cannot be switched from the P gear position to other gear positions by normal operation of the lever, emergency unlocking of P gear position can be performed.

CAUTION

- › In case of this breakdown, contact the authorised service centre and such breakdown shall be solved by the professionals. The operation, without any authorization, may damage the vehicle related parts.
- › When the shift lever needs emergency unlocking, it indicates that the vehicle has problems, head to authorised service centre for inspection and repair.

1. Shut down the vehicle and apply the parking brake.
2. Open the storage box and remove the pad from the bottom of the box.



3. At the notch in the square cover plate, use a flat-head screwdriver wrapped in cloth to pry the cover plate open to reveal the P gear unlocking cable.



4. Turn the P gear unlocking cable handle by approx. 60 degrees counter-clockwise to make it enter into the slide slot.

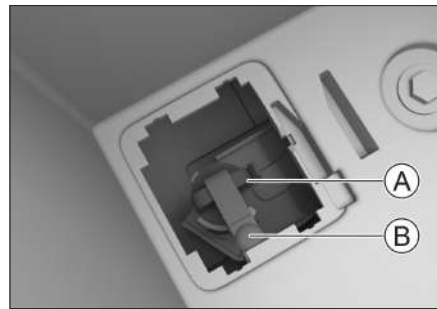

- Ⓐ P gear unlocking cable handle
- Ⓑ Cable

Automatic transmission

5. Lift the cable and pull the handle up to the top, and then turn the P gear unlocking cable handle clockwise by approx. 60 degrees. A slight "crack" will indicate that the handle is fixed and that the transmission is in P gear unlocking status. In this case, the vehicle sounds an alarm and the instrument shows that **【Transmission Failed to Shift to P Gear Position】**. At this time, the N gear position is engaged.
6. Immediately after moving the vehicle, follow the reversed procedure described above to return the P gear unlocking cable to its original position to avoid forcibly deactivating the transmission P gear position.

Crawling function

After the engine is started, you shall switch the shift lever to the driving position, and release the parking brake and the brake pedal. At this time, you don't need to step on the accelerator pedal, and the vehicle can crawl slowly.

Starting off the vehicle

1. Fasten the seat belt and confirm that the parking brake has been applied.
2. Start the engine.
3. When the engine speed is stable, engage the D gear (it is recommended to use the M gear for hill start which needs large output torque).

4. Release the brake pedal and then gently step on the accelerator pedal to allow the vehicle to accelerate.

i NOTICE

When you start off the vehicle, the automatic DAA function will automatically release the parking brake.

Stop the vehicle

1. After releasing the accelerator pedal, depress the brake pedal.
2. After the engine speed is stable, switch to the P gear.
3. Apply the parking brake or shut down the vehicle engine directly as required.

i NOTICE

After the vehicle engine is shut down, the vehicle will automatically apply the parking brake.

4. Release the brake pedal.

⚠ CAUTION

› When it is necessary to stop the vehicle temporarily at the slope, the brake pedal must be stepped on or the parking brake must be applied. Do not use accelerate pedal or crawling function to keep the vehicle stable, otherwise the transmission will be damaged.

Automatic transmission

- › Do not use the P gear to park on the slope, otherwise it will damage the transmission.
- › When stopping the vehicle on a slope, block the wheels with something if necessary to prevent rolling.

Power steering mode

Vehicle equipment

Please note that this manual contains all the standard equipment, country-specific equipment and special equipment for this model series. Thus, some equipment or features described in this manual may not be installed onto your vehicle or are only available in some markets. For further configuration information, please refer to relevant sales information or consult with your distributor selling the vehicle to you.

Switching method

Separate switching: when the power supply is in ON mode, the power steering mode, including light, comfort and sport, can be switched via the **【Vehicle Setting】** → **【Driving Setting】** → **【Steering Multi-mode】** on the multimedia display screen.

Linkage switching: when you switch to the all-terrain control system, the power steering mode is also switched by linkage.

All-terrain mode	Power steering mode
2H standard	Comfort
4H standard	Comfort
4H snow	Sport
4L standard, mud and stone, rock, hilly, bumpy	Comfort

i NOTICE

When switching between power steering modes, the following conditions need to be met:

- › The electric power steering system is functioning correctly.
- › The speed of the vehicle is less than 125 km/h.
- › No apparent turn operation has been carried out.

Light

It increases steering power for easy steering. It is applicable to traffic congestion driving environment such as urban areas.

Comfort

It is suitable for general driving habits.

Sport

It reduces steering power and increases steering wheel feedback. It is recommended to use it under high speed, rain and snow and other cases.

All-terrain control system

Vehicle equipment

Please note that this manual contains all the standard equipment, country-specific equipment and special equipment for this model series. Thus, some equipment or features described in this manual may not be installed onto your vehicle or are only available in some markets. For further configuration information, please refer to relevant sales information or consult with your distributor selling the vehicle to you.

All-terrain control system introduction

In complex road conditions, depending on the selected driving mode, the system will automatically optimize the vehicle's control systems to suit the terrain, improving steering ability, stability and cross-country capability.

4WD switching



D2848AF6DBC

Turn the 4WD mode knob to switch between 2H, 4H and 4L modes. When selecting a mode, the corresponding indicator light turns on. After switching is finished, the indicator light will be normally on.

- › Switching method in 2H and 4H: after the power supply is in ON mode or the engine is started, turn the 4WD knob when ensuring that the vehicle is stationary or running straight at a speed of less than 80 km/h.
- › Method to enter into or exit from 4L mode: once the engine has started, ensure that the vehicle is at a standstill, set the shift lever to N and turn the 4WD knob.

i NOTICE

- › If switching between the drive modes is abnormal and relevant alarm information appears on the instrument panel, follow the alarm prompt on the instrument panel to operate. After confirming that the switching condition is satisfied, try to switch the mode again.
- › When switching between the drive modes, it is normal that there may be a mechanical collision sound and a slight dash of the vehicle.
- › In 4H and 4L modes, the intelligent start-stop system is disabled and the electronic stability control system is turned off by default.

All-terrain control system

2

Driving

CAUTION

- › When driving on normal roads or motorways, never use the 4H or 4L mode. Otherwise, there will be noise, serious tyre wear, increased fuel consumption, damage to the drive system and other issues.
- › When the rear wheels of the vehicle skid on a snowy and icy road, never switch between the drive modes.
- › While driving in the 4H mode, the vehicle speed should be less than 80 km/h; otherwise alarm will occur and the vehicle parts may be damaged.
- › While driving in the 4L mode, the vehicle speed should be less than 40 km/h and avoid sharp turns; otherwise alarm will occur and the vehicle parts may be damaged.
- › When switching between 2H and 4H (or 4L) modes, there may be a 4WD gear shift delay (the indicator light on the 4WD knob flashes continuously and the instrument panel prompts you to move the vehicle). In this case, try driving straight ahead at a low speed (below 5 km/h) and move the vehicle slightly to complete the switching.

When entering into or exiting from 4L mode, if there is no time delay prompt of shifting gears, the vehicle should be stationary and kept in N gear until the mode switching is finished; otherwise, the transfer case may be damaged.

- › For driving in 4L mode, the hill descent control (HDC) system automatically turn on if the gear is shifted to manual mode. To ensure safe driving, do not turn off the hill descent control (HDC) system in this case.

Mode introduction

The 2H mode is used for pavement road or non-pavement road with good adhesion.

The 4H mode is used for non-pavement road with poor adhesion (such as snowy, muddy or sandy road).

The 4L mode is used for steep slope, vehicle rescue and other road conditions.

CAUTION

Do not leave the vehicle for a long period of time in scenarios of abnormal violent use such as tug-of-war or flying (a phenomenon in which the engine speed rises sharply after losing control and exceeds the maximum permissible speed and reaches a dangerous level), as this may cause damage to the relevant parts and affect the life of the vehicle.

All-terrain control system

All-terrain switching

⚠ CAUTION

- › If you use the driving modes incorrectly, the vehicle will respond erroneously to road conditions so that the service life of the suspension and transmission system will be reduced.
- › Before the vehicle enters a complex terrain, the driver should judge the terrain in advance and activate the appropriate all-terrain mode to avoid losing control of the vehicle.

The all-terrain control system is dependent on the four-wheel-drive mode. Switch to the four-wheel-drive mode first and then to the corresponding all-terrain mode.



2H mode

2H mode defaults to 2H  standard mode. You can not switch to other modes.

Switching between 4H modes



9D18288F46FB

With the power supply in ON mode and the vehicle in 4H mode, press the snow button  to switch between 4H  snow and 4H  standard mode.





i NOTICE

If the snow button is pressed in a mode other than 4H, the instrument will prompt you to enter 4H mode first. When 4H mode is entered, the instrument will display the mode icon and the 4H icon.

Switching between 4L modes



D24B467D3EF3

With the power supply in ON mode and the 4WD in 4L mode, turn the knob to switch between 4L  standard mode, 4L  mud and sand mode, 4L  rock mode, 4L  hilly mode and 4L  pot-hole mode. When a mode is selected, the corresponding indicator light will go on.

All-terrain control system







2

Driving

i NOTICE

- › If the knob is turned in a mode other than 4L, the instrument will prompt you to enter 4L mode first. When 4L mode is entered, the instrument will display the mode icon and the 4L icon.
- › When you switch between 4L modes, the corresponding assist function is automatically turned on or off, e.g. differential lock. Check the corresponding button indicator lights, instrument indicator lights or relevant prompts.

Mode introduction

- › 2H  standard mode: applicable to highways, paved roads, asphalt roads, concrete roads or hard surfaced road covered by a small amount of ice and snow. It can provide you with an optimized and balanced driving experience on good roads.
- › 4H  standard mode: applicable to loose and slippery road conditions such as desert, rainforest, shallow muddy road and so on; it can optimize the accelerator control to improve the response and torque output. The 4WD hard connection is not suitable for driving on hard paved surfaces.
- › 4H  snow mode: applicable to slippery road conditions such as thin snow, ice, grass, gravel and so on. The vehicle starts off at the second gear position and the power output in 4WD mode is smooth, you can enjoy great driving manoeuvrability and stability.
- › 4L  standard mode: applicable to steep slope, vehicle rescue and other road conditions. By increasing the primary reduction ratio, the vehicle is given maximum traction, providing effective power support for going over steep slopes and for vehicle rescue.
- › 4L  mud and sand mode: applicable to slippery and sinkable road conditions such as muddy ruts, deep snow and sand and soil road. The lower gears produce more power. The vehicle can make the best use of traction of all tyres to get strong power and great offroad ability.
- › 4L  rock mode: applicable to climbing on steps or rocks; also, it can automatically lock differential lock provided for the vehicle, optimise accelerator response and torque output and improve the vehicle climbing ability.
- › 4L  hilly mode: applicable to bumpy and slippery roads like hilly area, dirt and rock roads, to improve the vehicle dynamics and stability for better control of the vehicle.

All-terrain control system

4L  pothole mode: applicable to cross-axle, bun and other road conditions. The lower gears produce more power. The control of the electronic limited slip allows the non-skidding wheels to gain strong torque and improve the vehicle passing ability.

Expert mode

You can customize the vehicle's drive mode, steering mode, and ESC switch according to your driving needs, so that the vehicle is more suitable for your control mode and comfort.



61406A19E59C

When the power supply is in ON mode and the vehicle is in 2H normal mode or 4H normal mode, press the expert mode button , and the central display screen will pop up a prompt interface. Touch the **【OK】** button to enter the expert mode interface.

You can select a custom mode 1, 2 or 3 according to your driving needs.

You can set the drive mode, steering mode and ESC switch in the custom mode 1, 2 or 3 respectively. You can touch the **【Reset】** button to restore the default settings.

You can touch the **【Exit】** button to exit the expert mode.

When the expert mode interface is hidden, press the expert mode button  to call up the expert mode interface again.

› The drive mode can be selected from NORMAL, SPORT and ECO modes.

ECO: with improved vehicle fuel economy, the mode is applicable to urban roads, pavement and other flat hard road surfaces.

NORMAL: integrating vehicle dynamics and economy, the mode is applicable to all kinds of road.

SPORT: it increases the vehicle power, resulting in a higher level of responsiveness and driving experience. It is suitable for use on wide, flat roads with few vehicles.

› The steering mode can be selected from Comfort, Sport or Light modes.

For mode introduction, please refer to (▷ Page 114)

› The ESC setting can be selected from ALL-ON, TCS&VDC-OFF and ALL-OFF modes.

ALL-ON: the Electronic Stability Control (ESC) is on.

All-terrain control system

TCS&VDC-OFF: the Traction Control System (TCS) and Vehicle Dynamic Stability Control (VDC) are off.

ALL-OFF: ESC is off.

Operating precautions for driving 4WD vehicles

› It is forbidden to perform 2WD hub tests in 4H and 4L mode (including the operation where the front wheel does not turn, and the rear wheel continues to slip on the raceway or on the ice and snow road).

› Ensure that the rolling radius of the four wheel tyres of the vehicle is consistent:

If a tyre needs to be replaced, ensure that all four tyres used on the vehicle after the replacement are of the same brand and model;

If it is not possible to guarantee the consistency of the tyres (including the replacement of a non-full-size spare tyre), the vehicle must be driven in the 2H mode and the tyre must be replaced as soon as possible (with a mileage of no more than 50 kilometres) to ensure that all four tyres are of the same brand and model;

If there is a tyre pressure warning, it must be confirmed in time, and the tyre pressure should be replenished in time to cancel the warning.

› Avoid operation in drifting conditions.

› On high-adhesion roads (such as normal roads and cement grounds), 4H and 4L modes are not allowed to use.

› Do not start the vehicle or turn the tyres when lifting a vehicle in 4H and 4L modes with a jack.

Otherwise, the vehicle may detach from the jack and rush out, which is very dangerous.

2

Driving

Differential lock

Vehicle equipment

Please note that this manual contains all the standard equipment, country-specific equipment and special equipment for this model series. Thus, some equipment or features described in this manual may not be installed onto your vehicle or are only available in some markets. For further configuration information, please refer to relevant sales information or consult with your distributor selling the vehicle to you.

Differential lock introduction

When a drive wheel slips, the differential lock will ensure that the other drive wheel is still able to get enough torque to provide an enough driving force for the vehicle to get out of trouble.

⚠ CAUTION

- › Do not modify the powertrain assembly and transmission system of the vehicle to avoid damage to the differential lock.
- › Do not use the differential lock on a paved road.
- › The differential lock is only used for the vehicle to get out of trouble, which shall be deactivated immediately after the vehicle is out of trouble.

- › Control the vehicle carefully after the differential lock is locked. Emergency turning is not allowed, otherwise the stability of the vehicle will be seriously affected and the risk of accidents will be increased.

Rear axle electric differential lock

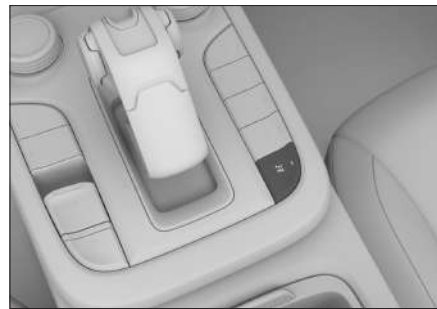



1EA441206697

Manual locking

i NOTICE

It can be locked normally only when the following basic conditions are met:

- › The vehicle speed is less than 5 km/h.
- › The left and right wheel speed difference is less than 50 rpm.
- › Steering assist function is not activated.



After starting the engine, press the  button. When the indicator on this button turns on and the  indicator on the instrument is displayed in green, the rear axle differential lock has been locked successfully.

Differential lock



WARNING

When the differential lock is locked, reduce large angle turning, otherwise vehicle components may be damaged.

NOTICE

When the rear axle differential lock is unlocked, press the button . When the indicator on this button flashes for a few seconds and then goes out, and the indicator  on the instrument flashes (yellow) for a few seconds and then goes out, the rear axle differential lock has failed to lock. Make sure that the conditions are met before operating.



Manual unlocking

When the rear axle differential lock is locked, press the  button again. When the indicator on this button and the indicator  on the instrument go out, the rear axle differential lock has been unlocked successfully.



NOTICE

When it is difficult to unlock the vehicle, the steering wheel can be gently turned to the left and right to assist in unlocking.

Speeding alarm

When the rear axle differential lock is locked, and the vehicle speed increases to 30 to 40 km/h, the indicator  on the button flashes, and the indicator  on the instrument flashes green to prompt the driver to reduce the speed.

Speeding automatic unlocking

When the rear axle differential lock is locked, and the vehicle speed is more than 40 km/h, the rear axle differential lock will be automatically unlocked, and the indicator on the button  and the indicator  on the instrument go out.

Linkage locking

The rear axle differential lock is also locked by linkage when the all-terrain control system is switched to.

The rear axle differential lock is automatically locked when switching from the all-terrain mode to rock mode is made and the locking conditions are met.

The all-terrain control system switches to other modes and the rear axle differential lock is automatically unlocked.

NOTICE

Speeding will not automatically unlock the differential lock after linkage locking.

Front axle electric differential lock

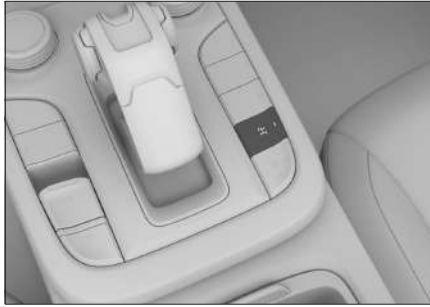



C691E6A2AAA4

Manual locking

i NOTICE

It can be locked normally only when the following basic conditions are met:



- › The vehicle speed is less than 5 km/h.
- › The rear axle differential lock is locked.
- › The driving mode is in 4L mode.
- › The left and right wheel speed difference is less than 50 rpm.

After starting the engine, press the button . When the indicator on this button turns on and the indicator  on the instrument is displayed in green, the front axle differential lock has been locked successfully.



! WARNING



When the differential lock is locked, reduce large angle turning, otherwise vehicle components may be damaged.

i NOTICE

When the front axle differential lock is unlocked, press the button . When the indicator on this button flashes for a few seconds and then goes out and the indicator  on the instrument flashes (yellow) for a few seconds and then goes out, the front axle differential lock has failed to lock. Make sure that the conditions are met before operating.

Manual unlocking

When the front axle differential lock is locked, it can be unlocked by means of the following methods, and the indicator on the button  and the indicator  on the instrument go out after unlocking.



- › Press the button  to unlock the front axle differential lock.
- › Press the  button, the rear axle differential lock will be unlocked, and the front axle differential lock will also be unlocked.
- › After the drive mode exits from 4L mode, the front axle differential lock will be unlocked.

i NOTICE

When it is difficult to unlock the vehicle, the steering wheel can be gently turned to the left and right to assist in unlocking.

Differential lock



Speeding alarm

When the front axle differential lock is locked, and the vehicle speed increases to 30 to 40 km/h, the indicator  on the button flashes; and the indicator  on the instrument flashes green to prompt the driver to reduce the speed.

2

Driving

Speeding automatic unlocking

When the front axle differential lock is locked, and the vehicle speed is more than 40 km/h, the front axle differential lock will be automatically unlocked, and the indicator on the button  and the indicator  on the instrument go out.

Intelligent start-stop system

Vehicle equipment

Please note that this manual contains all the standard equipment, country-specific equipment and special equipment for this model series. Thus, some equipment or features described in this manual may not be installed onto your vehicle or are only available in some markets. For further configuration information, please refer to relevant sales information or consult with your distributor selling the vehicle to you.

Intelligent start/stop system introduction

The intelligent start/stop system can help save fuel and reduce carbon dioxide emissions.

The intelligent start/stop system can make the engine automatically shut down when the vehicle is at rest (such as waiting at a red traffic light). The engine automatically starts quickly upon the driving demand.

Instructions for use

Turning on/off method

With the power supply in the ON mode, the intelligent start/stop system can be turned on or off through the **【Vehicle setting】** → **【Driving setting】** → **【Intelligent start/stop】** on the multimedia display screen.

CAUTION

Before wading, turn off the intelligent start/stop system.

NOTICE

The intelligent start/stop system can be used normally only if the following basic conditions are met:

- › The engine hood is closed.
- › The driver door is closed.
- › The driver wears the seat belt properly.
- › Every time the vehicle stops and starts, the vehicle speed has exceeded 10 km/h.

AT vehicle

- › For driving in the gear D, the automatic engine shutdown is achieved by depressing the brake pedal deeply to stop the vehicle stably, without releasing the brake pedal.
- › With the automatic shutdown, release the brake pedal, and the engine will automatically start again.

NOTICE

- › With the automatic shutdown, the engine will not start automatically when the electronic parking brake is applied or the AVH function is active, and the brake pedal is released.

Intelligent start-stop system

› With the automatic shutdown, the engine will start automatically when the accelerator pedal is depressed or the gear other than the gear N and P is engaged.

› The vehicle is in the all-terrain mode which does not allow start-stop.
› Certain systems that do not allow start-stop are in the ON status. For example, hill descent control system

Safety function

The engine will not automatically shut down if one of the following cases occur:

- › The engine water temperature has not yet reached the minimum temperature that can make the intelligent start/stop system work properly.
- › The working state of the A/C system does not allow the engine to automatically shut down.
- › The battery level or voltage is below the limit.
- › The battery temperature is above or below the limit.
- › The automatic transmission operating state can not meet shutdown requirements.
- › The braking vacuum is insufficient due to the continuous stepping on the brake pedal.
- › The angle of rotation of the steering wheel is too large.
- › The vehicle is at higher altitudes.
- › The ambient temperature is beyond the allowable range.
- › The slope of the road surface is large.

The engine will not start automatically when the following conditions occur in the automatic shutdown:

- › The driver's door is open.
- › The engine hood is open.
- › The driver seat belt is released.

At this time, the engine can only be started by pressing the power supply switch.

The engine will start automatically when the following conditions occur in the automatic shutdown:

- › The intelligent start/stop system is turned off manually.
- › The vehicle is rolling and the speed is more than 3 km/h.
- › The battery level or voltage is below the limit.
- › The battery temperature is higher than the limit.
- › The braking vacuum is insufficient due to the continuous stepping on the brake pedal.
- › The working state of the A/C system needs to start the engine automatically.
- › Turning the steering wheel.
- › Switching to the all-terrain mode that does not allow start-stop;

Intelligent start-stop system

CAUTION

About the battery

- › Do not replace or remove the battery by yourself.

If you need to replace the battery, be sure to go to the authorised service centre for replacement. Otherwise, the battery sensor may be damaged and the system may not work properly.

- › When you are unable to start the vehicle after a long period of storage due to low battery levels, you may connect another battery to help jump start the engine.

Do not charge the battery using other power supplies. Failure to adhere to this advise will lead to the malfunctioning of the intelligent start-stop system. We recommend that the battery be charged using power generated by the vehicle.

Parking assist system

Vehicle equipment



Please note that this manual contains all the standard equipment, country-specific equipment and special equipment for this model series. Thus, some equipment or features described in this manual may not be installed onto your vehicle or are only available in some markets. For further configuration information, please refer to relevant sales information or consult with your distributor selling the vehicle to you.

Parking assist system sensor

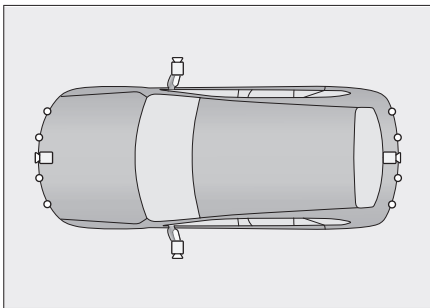
The parking assist system detects the traffic situations around the vehicle using cameras and ultrasonic radars, and assists the driver in taking appropriate measures based on the detection results to improve safety and comfort when parking.



456A2668E288

Illustration	Description	Position
	Camera	On the front grille; On the tailgate; On the left and right side mirrors.
	Ultrasonic radars	On the front and rear bumpers

i NOTICE

Sensor types and quantities may vary based on vehicle configurations. Please refer to the actual vehicle.

! WARNING

- › The parking assist system is only an auxiliary tool and cannot be a substitute for the driver's judgement on the external situation. In any case, the driver should be responsible for the safety of the vehicle and observe the surrounding conditions of the vehicle at any time during parking or similar operations.
- › There are blind spots to the coverage of the parking assist system, and obstacles in certain areas may not be detected. Therefore, during parking or similar operations, please make sure that there are no children or animals near the vehicle.

Parking assist system

⚠ CAUTION

- › When reversing, confirm that the tail-gate is fully closed.
- › Do not knock on the camera and the radar.
- › Do not flush the camera and the radar with a high-pressure water gun in the front. Otherwise, water may result in system failure or fire.
- › Do not use rough or sharp material to clean the camera and the radar. Please wipe with a soft cloth or wash with water (low water pressure) to clean the surface of the camera and the radar.

i NOTICE

When the parking system is working, affected by the characteristics of radar, the following situations may cause the parking system to be less effective in recognizing or not recognizing obstacles, resulting in damage to the vehicle, including but not limited to:

- › Objects that are in the blind spot of radar detection, such as short objects, objects under bumpers, objects that are too close or too far from the vehicle.
- › Hanging objects that cannot be detected, e.g. fire boxes, vehicle spare tyre, and rear of trucks.

- › There are ultrasonic noises with the same frequency around, such as metal noise, high-pressure gas emission noise, or a car horn directed at the radar.
- › The obstacle is a wire net, fence, thin post, rope, shopping cart, two-wheeled vehicle, or other thin object that cannot reflect effective sound waves.
- › The obstacle is snow, cotton or other substances of which the surface can easily absorb sound waves.
- › The obstacle is an object whose surface does not reflect the detection signal or a person wearing such clothing.
- › The obstacle is a cone-shaped object or an object with an inclined surface.
- › The obstacle is a right-angle object such as a corner of a wall or the rear of a vehicle.
- › The vehicle is parked on grassy or bumpy roads.
- › The license plate is bent or tilting, or a large license plate decorative frame is installed.
- › The radar is damaged, misaligned, or obscured by foreign objects (e.g. paint protective film).
- › To ensure the normal operation of the system, the radar must be kept clean and free of snow and ice.

Parking assist system

Anti-collision radar

System description

An anti-collision radar is a radar detection device. During parking, sensors are used to detect whether there are obstacles in front of and behind the vehicle, detect the distance of obstacles, and give sound prompt to assist the driver to park safely and easily.

Instructions



A53C99CB1502

- › When the power supply is set to the ON mode or the engine is started, press the button to manually turn on or off the anti-collision radar.
- › Switch to the R gear position and the anti-collision radar will automatically turn on.
- › Switch to the P gear position and the anti-collision radar will automatically turn off.
- › If the driving speed exceeds 15 km/h, the anti-collision radar will be automatically stopped.

Detection scope and alarm mode

Radar sensor position	Detection scope [m]
Front on both sides	0.6
Front centre	1.0
Rear on both sides	0.6
Rear centre	1.5

After the anti-collision radar is activated, if the sensor detects obstacles within the detection scope, it will start to give an alarm.

As the distance between the vehicle and the obstacle shortens, the frequency of the alarm sound will gradually increase. When the distance between the obstacle and the vehicle is within approximately 0.5 m, a long alarm will be sounded and the vehicle must not continue to run at this time in order to avoid a collision.

Front radar auto ON

The front radar auto ON can be activated or deactivated through the **【Vehicle Setting】** → **【Parking Setting】** → **【Radar Setting】** on the multimedia display screen.

Parking assist system

After the function is enabled, if the moving speed is less than 10 km/h and there is an obstacle detected within the detection scope, the front radar and AVM system will be started automatically. The system will be automatically turned off if within a few seconds the distance of the obstacle does not change, the obstacle is far away, or the vehicle is applying the parking brake.

Manoeuvre emergency braking function

The manoeuvre emergency braking function can be activated or deactivated through the 【Vehicle Setting】 → 【Parking Setting】 → 【Radar Setting】 on the multimedia display screen.

After the function is activated, when the vehicle is running at a low speed, the manoeuvre emergency braking indicator light  on the AVM interface will be illuminated in green, which indicates that the function is normally activated. If an obstacle is detected during low speed driving and a collision risk is determined, the system will automatically apply emergency braking to reduce the risk of a collision. At this moment, the indicator light turns into red.

CAUTION

- › The function is only an auxiliary one, which cannot guarantee that all obstacles are detected under all conditions.

- › Under complex road conditions (such as off-road conditions or narrow passages), please turn off the manoeuvre emergency braking function. Otherwise, the system may apply unnecessary braking.
- › Turn off the manoeuvre emergency braking function after the vehicle is equipped with a traction hitch or when the vehicle is towing other vehicles. Otherwise, the system may apply unnecessary braking.

Around view monitor (AVM)

System description

AVM uses four cameras to capture images surrounding the vehicle and sends a video signal to the display screen for display. This helps the driver safely and easily drive to avoid accidents.

Instructions

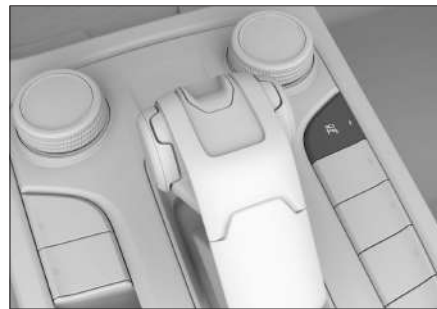

A53C99CB1502

- › When the power supply is set to ON mode or the engine is started, press the button to turn on or off the AVM.

Parking assist system

- › When the R gear position is engaged, the AVM will turn on automatically.
- › When the P gear position is engaged, the AVM will turn off automatically.
- › The AVM will turn off automatically when the vehicle speed exceeds the set value.

You can set the exit AVM speed limit through the **【Vehicle Setting】** → **【Parking】** → **【AVM Status】** interface on the multimedia display screen.

- › You can activate or deactivate the turn indicating Auto On through the **【Vehicle Setting】** → **【Parking】** → **【AVM Status】** interface on the multimedia display screen.

After the function is activated, set to D gear position and turn on the turn signal light or turn the steering wheel to a certain angle, and then the AVM will automatically turn on. After the steering wheel is restored, the AVM will automatically turn off when the turn signal light is off or the vehicle speed exceeds a certain value.

Interface layout

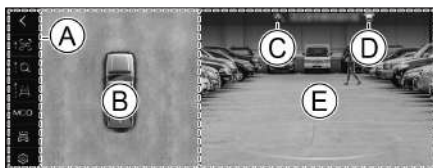

940B774D3BC7

- Ⓐ Function setting area
- Ⓑ Top view area

- Ⓒ Maneuver emergency brake function indicator light

Green: it indicates that the maneuver emergency brake function is normally activated.

Red: it indicates that an obstacle is detected and auto emergency braking is performed.

Yellow: it indicates abnormal function.

- Ⓓ View identification

In 2D view mode, it indicates the orientation of the current view.

- Ⓔ Image area

View switching

Auto view switching

When the D gear position is engaged, it will automatically switch to the front view image; when the R gear position is engaged, it will automatically switch to the rear view image; in the D gear position, turn on the left turn signal light and the image area will automatically switch to the front left wheel image, or turn on the right turn signal light and the image area will automatically switch to the front right wheel image.

Manual view switching

When the vehicle speed is less than 10 km/h, touch the top view area to display the direction button. Touch the button indicating each direction, and then the image area will display the view image corresponding to this button.

Parking assist system



Ⓐ Engine compartment transparent view button

In 3D view mode, touch the transparent view button of the engine compartment, and then the image interface will gradually display the image of the road under the engine compartment as the vehicle runs.

Function setting

<: back button

Touch the back button to return to the previous interface. Touch the back button on the main interface to exit from the image interface.

☰: mode switch button

Touch the button to switch between 2D and 3D view modes.

🔍: view switch button

Touch the button to switch among 🔍 (Normal Mode), 🛞 (Wheel Mode), and 🛞 (Cross Mode).

🚗: car model auxiliary line setting button

You can switch between the auxiliary line display modes by repeatedly touching the car model auxiliary line setting button. When it is set to display mode, the guide line displays the body width, which can assist the driver in parking.

📌 NOTICE

Considering different vehicle model configurations, this button is located under the system setting menu for certain models.

MOD: moving object detection

You can activate or deactivate the moving object detection function. After the function is activated, when a moving pedestrian is detected, the AVM interface will display an alarm prompt message.

📌 NOTICE

Considering different vehicle model configurations, this button is located under the system setting menu for certain models.

🚿: vehicle washing station mode

Touch the button to enable or disable the vehicle washing station mode. After the vehicle washing station mode is enabled, the tyre track will be displayed, and the line width indicates the tyre width.

⚙️: system setting

Touch the setting button to enter the system setting interface. The following items can be set on the system interface.

> Intelligent view switching

You can activate or deactivate the intelligent view switching function. After the function is activated:

Parking assist system

When the vehicle is in the D gear position, if the front radar detects an obstacle less than or equal to 1 m from the vehicle body, it will automatically switch to the front top view image.

When the vehicle is in the R gear position, if the rear radar detects an obstacle less than or equal to 1 m from the vehicle body, it will automatically switch to the rear top view image.

It will automatically switch to the previous image after the obstacle is removed.

› Car model color

The car model color can be changed.

› Car model transparency

In the 3D view mode, touch the car model transparency setting button to change the model transparency.

When the car model transparency is selected as 100%, the chassis transparency function will be activated.

After the chassis transparency is activated, the image interface will gradually display the image of the road under the vehicle as the vehicle moves.

i NOTICE

The chassis transparency function is not real-time and the AVM interface does not fully reflect the environment under the vehicle. The driver has to make his own judgement of the external situation and cannot rely entirely on this function.

› Radar display

Touch the radar display setting button repeatedly to change the radar display mode. After the setting is shown and when an obstacle is detected, a radar sign will be shown in the obstacle direction.

› Radar alarm

You can set the radar alarm volume by dragging the sliding block. Touch the **【Default】** button to restore the alarm volume to the default volume.

Road calibration setting

You can re-conduct the road calibration through the **【Vehicle Setting】** → **【Parking】** → **【AVM Status】** interface on the multimedia display screen.

When the camera position changes due to loading, bumping of vehicles, or ageing of parts, the image mosaic may be misplaced, blurred and distorted. At this time, the image mosaic effect can be optimized through the road calibration setting.

Refer to the prompt information on the multimedia display for the specific calibration methods and requirements.

Factory setting

You can make the factory setting through the **【Vehicle Setting】** → **【Parking】** → **【AVM Status】** interface on the multimedia display screen.

Parking assist system

After re-calibrating the road, you can restore the factory calibration by pressing the Factory Setting button.

2

Driving

Tyre pressure monitoring system

Vehicle equipment

Please note that this manual contains all the standard equipment, country-specific equipment and special equipment for this model series. Thus, some equipment or features described in this manual may not be installed onto your vehicle or are only available in some markets. For further configuration information, please refer to relevant sales information or consult with your distributor selling the vehicle to you.

System introduction

The tyre pressure monitoring system (TPMS) monitors tyre pressure and temperature in real time and alerts the driver to take appropriate action to avoid an accident when an abnormality occurs in the tyre.

CAUTION

- › Tyre repair methods such as tyre repair liquid (except for tyre repair liquid provided by authorised service centre), carburetor cleaning agent and inflation may damage the tyre pressure sensor, resulting in failure of TPMS.
- › If the tyre replaced is not a standard spare tyre, it may affect the normal operation of TPMS.

- › The tyre pressure sensor is installed near the valve inside the tyre. Please contact authorised service centre for tyre repair or replacement to avoid damage to the tyre pressure sensor due to incorrect operation, resulting in failure of TPMS.
- › TPMS may not work properly when the tyre chain is installed or the wheel is covered.
- › TPMS may not work properly due to radio interference.

NOTICE

- › TPMS cannot replace regular tyre maintenance. Check the tyre frequently to ensure proper tyre pressure, even if no alarm is received from TPMS.
- › Tyre pressure can be affected by factors such as the heat generated from vehicle operations, the external environment, journey time, etc. Under normal conditions, the tyre pressure fluctuates around 30 kPa, which is normal.
- › TPMS is unable to monitor pressure of spare tyre.

Adaptive learning function







The data can be automatically updated through the adaptive learning function after tyre replacement or tyre rotation.

Tyre pressure monitoring system

After parking for more than 16 minutes, start the vehicle to run for about 9 minutes at a speed higher than 30 km/h, and the system will automatically complete tyre pressure learning and positioning.

If the adaptive learning fails, please contact authorised service centre as soon as possible to reset the TPMS.

Monitoring function

Press the  menu button on the steering wheel to call out the multi-function tab bar, and then press the  left or  right button to switch the instrument information center to the  driving data interface. Press the  up or  down button on the driving data interface to call out the tyre pressure monitoring interface to view the pressure and temperature information of the four tyres in use in real time.

When the tyre pressure is too low or the temperature is too high, the abnormal tyre icon on the tyre pressure monitoring interface shows red and flashes.

Alarm function

When the tyre pressure is too low or the temperature is too high, the instrument cluster will send out the following alarm as follows:

- › The multi-information display will display the corresponding alarm interface. The abnormal tyre icon is displayed as red and sends out audible alarm.
- › Tyre pressure monitoring system warning lamp  on the instrument cluster illuminates.

If the tyre alarm message appears in the trip, you should avoid performing sudden, acute turns and emergency braking. Reduce the speed, drive to a safe area and stop the vehicle as soon as possible. Then contact authorised service centre for trouble handling.

Cruise control assist system

Vehicle equipment

Please note that this manual contains all the standard equipment, country-specific equipment and special equipment for this model series. Thus, some equipment or features described in this manual may not be installed onto your vehicle or are only available in some markets. For further configuration information, please refer to relevant sales information or consult with your distributor selling the vehicle to you.

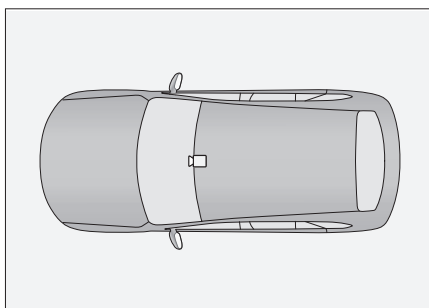

9226A777412C

Illustration	Description	Position
	Camera	Near the base of the interior rear-view mirror

Cruise control assist system sensor

The cruise control assist system detects the traffic situations in front of the vehicle using a camera, and assists the driver in taking appropriate measures based on the detection results to improve the safety and comfort while the vehicle is travelling.

While you drive on straight, smooth motorways, the cruise control assist system allows you to keep the vehicle at a certain speed without stepping on the accelerator pedal. When the system detects that the vehicle in front of you is moving at a speed less than the cruising speed set for your vehicle, the vehicle will follow the preceding vehicle at a set safe distance.

WARNING

- › The cruise control assist system is only an auxiliary tool. It is not a substitute for the driver's judgement on road and traffic conditions and for the driver's driving. Under any circumstances, the driver should be responsible for the safety of the vehicle and must concentrate on driving carefully at all times.
- › Incorrect use of cruise control assist system may result in a crash.
- › The cruise control assist system can only be used when you drive on a clear road in good weather conditions.

Cruise control assist system

- › The cruise control assist system is not recommended for use in conditions such as urban areas, winding roads, narrow roads, wet and slippery roads, heavy rain or other harsh weather conditions.
- › The cruise control assist system may exit when the camera is exposed to strong light or the light intensity changes suddenly.
- › The camera may be affected when the front windscreen around the camera is polluted, frozen, damaged or covered.
- › When you drive on a slope, the cruise control assist system is not recommended for use, based on the following points:

The cruise control assist system cannot maintain the set speed when you drive up and down the slope.

After a preceding vehicle has passed the top or bottom of a slope, the cruise control assist system may not detect the preceding vehicle, causing sudden acceleration or late braking.
- › When your vehicle is towing other vehicles, the cruise control assist system cannot work normally and is prohibited at this time.

About the camera

The camera is used to identify lane markings, and targets in front of the vehicle, etc., providing relevant information for the cruise control assist system.

WARNING

- › It is strictly prohibited to disassemble or modify the camera without permission.
- › When the camera does not work properly, the function of relying on the camera to provide lane marking and target information will be limited.
- › The camera has a limited detection range and cannot detect the targets outside the limit range.
- › When the camera fails or is damaged, please contact the authorised service centre in time for repair or replacement.

WARNING

Many factors will affect the performance of the camera, resulting in detection performance degradation, detection delay, and detection errors. These factors include but are not limited to the followings:

- › Poor lighting conditions at night;
- › Weather conditions (such as rain, snow and fog) with poor visibility;

Cruise control assist system

- › A situation in which a vehicle wobbles due to an undulating or uneven road;
- › A situation where the ambient light changes sharply;
- › A situation where a strong light shines the camera;
- › Deformed or damaged windscreen, causing the incorrect camera installation position and angle;
- › Complex intersections;
- › Too high or too low ambient temperature;
- › A situation where the camera is covered with a foreign object;
- › Short following distance and blocked camera;
- › A situation where a guardrail, an elevated road or a tree casts a shadow on a road;
- › Poor tunnel light;
- › A situation of passing through narrow bends and sharp turns;
- › Unclear lane markings.

Instructions

Type I

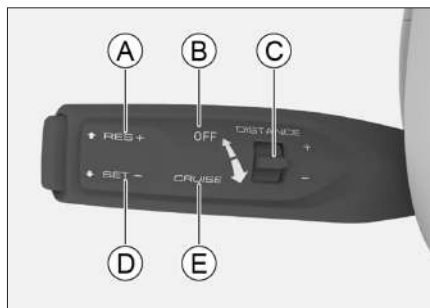

83256DE733C5

- Ⓐ Restoring speed setting/acceleration
- Ⓑ Cancelling speed setting/turning off the system
- Ⓒ Distance level adjustment lever
- Ⓓ Speed setting/deceleration
- Ⓔ Turning on the system

Type II

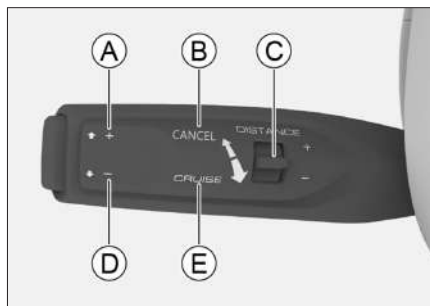

653F40BF4B0E



- Ⓐ Restoring speed setting/acceleration
- Ⓑ Cancelling speed setting/turning off the system
- Ⓒ Distance level adjustment lever
- Ⓓ Speed setting/deceleration
- Ⓔ Turning on the system



Cruise control assist system

Turning on the system



After starting the vehicle, move the control lever in the direction of the steering wheel to the 【CRUISE】 position. If the adaptive cruise control system indicator light (white)  on the instrument panel goes on, it indicates that the adaptive cruise control assist system is enabled.

i NOTICE

For vehicles equipped with the intelligent cruise control assist system, when the system is activated, the adaptive cruise control assist system () and intelligent cruise control assist system () can be selected by repeatedly toggling the control lever.

- › If the adaptive cruise control system indicator light (white)  on the instrument panel goes on, it indicates that the adaptive cruise control assist system is enabled.
- › If the intelligent cruise control assist indicator light (white)  on the instrument panel goes on, it indicates that the intelligent cruise control assist system is enabled.

Setting the cruising speed

Push the control lever downwards to the 【SET-】 / 【-】 position, and the control lever will automatically return after releasing, and then the vehicle speed can be set. After the vehicle speed is successfully set, the adaptive cruise control system indicator light  or intelligent cruise control assist indicator light  on the instrument panel turns from white to green.

The minimum set speed of the cruise control assist system is 30 km/h.

i NOTICE

To set the cruising speed when the adaptive cruise control assist system is activated, the following basic conditions must be met:

- › All doors are completely closed.
- › The driver wears the seat belt properly.
- › The engine is started and the D gear position is engaged.
- › The ESC is activated.
- › No parking brake is applied.
- › The vehicle speed is less than 150 km/h.
- › The vehicle driving mode is the 2H standard mode.

To set the cruising speed when the intelligent cruise control assist system is activated, the following basic conditions must be met:

Cruise control assist system

- › All doors are completely closed.
- › The driver wears the seat belt properly.
- › The engine is started and the D gear position is engaged.
- › The ESC is activated.
- › No parking brake is applied.
- › The vehicle speed is less than 150 km/h.
- › The system has detected the lane boundaries.
- › If the vehicle speed is less than 60 km/h, it is required to detect the moving targets.
- › The vehicle driving mode is the 2H standard mode.

Increasing the cruising speed

There are three methods to increase the set speed:

- › Push the control lever upwards to the **【RES+】 / 【+】** position and hold it to increase the vehicle speed continuously and release the control lever when the desired speed is reached.
- › Push the control lever upwards to the **【RES+】 / 【+】** position to increase the vehicle speed.
- › Step on the accelerator pedal to accelerate the vehicle to the desired speed, and push the control lever downwards to the **【SET-】 / 【-】** position to set a new speed.

i NOTICE

The vehicle will accelerate to the set speed only when the road ahead is clear. Otherwise, your vehicle will follow the front vehicle at the set distance level.

Reducing the cruising speed

There are three ways to reduce the cruising speed:

- › Push the control lever downwards to the **【SET-】 / 【-】** position and hold it to reduce the vehicle speed continuously and release the control lever when the desired speed is reached.
- › Push the control lever downwards to the **【SET-】 / 【-】** position to reduce vehicle speed.
- › Step on the brake pedal to slow down the vehicle to the desired speed, and push the control lever downwards to the **【SET-】 / 【-】** position to set the new speed.

Accelerating temporarily

To accelerate temporarily during vehicle speed setting, depress the accelerator pedal. After acceleration, you can release the accelerator pedal to resume the previously set speed.

Adjusting the distance level

Toggling the distance level adjustment lever can adjust the following distance to the vehicle ahead.

Cruise control assist system

WARNING

Setting up a low distance level may result in a delay in reaction in the event of unexpected situations, and it is always your responsibility to adjust the distance level appropriately.



NOTICE

- › The distance level is not a fixed distance, and the actual distance between your vehicle and the preceding vehicle will vary with the speed of your vehicle.
- › Compared with driving on a dry road, driving on a slippery road requires a greater distance level.

Canceling the set speed

There are two ways to cancel the set speed:

- › Depress the brake pedal.
- › Move the control lever away from the **【OFF】** / **【CANCEL】** position.



After the set speed is cancelled, the system is not turned off, and the adaptive cruise control system indicator light  or intelligent cruise control assist indicator light  on the instrument panel turns from green to white.

NOTICE

The set speed will automatically cancel under any of the following circumstances:

- › Depress the accelerator pedal to accelerate for more than 15 minutes.
- › The N, R or P gear position is engaged.
- › The driver seat belt is released.
- › The driver door is opened.
- › The parking brake is applied.
- › The anti-lock brake system is activated.
- › The hill descent control system is activated.
- › The electronic stability control (ESC) is activated or deactivated.
- › The vehicle rolls backwards.
- › The brake disk is overheated.
- › The engine is shut down.
- › The vehicle driving mode is a non-2H standard mode.

Restoring the set speed

After the set speed is cancelled, the system does not turn off. Push the control lever to the **【RES+】** / **【+】** position and then release it to automatically restore to the set speed before cancelling. At this point, the adaptive cruise control system indicator light  or intelligent cruise control assist indicator light  on the instrument panel turns from white to green.

Cruise control assist system

Turning off the system

Push the control lever twice away from the steering wheel to the **【OFF】** / **【CANCEL】** position successively to turn off the system and cancel the previously set speed, and the indicator light on the instrument panel goes out.

If the set speed is already cancelled for the system, turn the control lever to the **【OFF】** / **【CANCEL】** position once to turn off the system, and the indicator light on the instrument panel goes out.

Queuing auxiliary function

This function enables the vehicle to follow another vehicle within the speed range of 0~150 km/h.

In the event of traffic congestion, the vehicle can be slowed down to a stop following the preceding vehicle. At this point:

- › If the preceding vehicle leaves within 3 s, the vehicle will automatically follow the preceding vehicle.
- › If the preceding vehicle stops for a long time (3 s to 3 min), either push the control rod upwards or lightly step on the accelerator pedal can restart the system.
- › If the preceding vehicle is parked for more than 3 minutes, the vehicle will automatically apply the parking brake.
- › If the driver opens the door or releases the seat belt, the vehicle will automatically apply the parking brake.

i NOTICE

After the cruise function is cancelled, the queuing auxiliary function is automatically disabled.

Curve road auxiliary function

When cruise assist system is enabled, if the vehicle is entering a curve road at too high speed, the curve road auxiliary function will reduce the vehicle speed appropriately.

! WARNING

- › When entering and exiting a curve road or driving in a curve road, the system may not detect the vehicle in front of the same lane in a timely manner, in which case the vehicle may be braked too late, and the driver must be careful and ready to control the vehicle.
- › When driving around a curve road, the system may incorrectly detect vehicles in other lanes, causing unnecessary braking.
- › When driving on a sharp turn road (for example, a serpentine road), if the vehicle in front exits the sensor detection scope, the vehicle may suddenly accelerate, and the driver must be cautious and ready to manipulate the vehicle.

Cruise control assist system

Lane center keeping function during cruising

This feature is only available in TJA mode, which assists the driver in keeping the vehicle in the middle of the lane boundary when the system is operating and the sensor detects a lane boundary or a moving vehicle ahead.

i NOTICE

- › This feature is not available in adaptive cruise control mode.
- › This function is cancelled at the same time when the set cruise speed is cancelled.

! CAUTION

In some cases, the lane center keeping function may not work properly or not work during cruising. For example,

- › Cruise at a speed higher than 60 km/h (including 60 km/h), there are no lane lines, lane lines at both sides are blurred, and the non-standard lane boundaries or lane boundaries are covered.
- › Cruise at a speed below 60 km/h, there are no lane lines or the lane lines on both sides are blurred, the non-standard lane boundaries or the lane boundaries are covered, and there is no vehicle running ahead.

- › There is an object on the road that affects the identification of the lane boundaries (such as water, gaps, ruts, text signs, bumps or pits).
- › Low visibility (such as rain, snow, fog and night etc.).
- › The vehicle is strongly affected by the side wind.
- › The lanes merge or separate.
- › The camera is illuminated by strong light or the illumination intensity changes suddenly.
- › The front windscreen around the camera is polluted, frozen, damaged or covered.
- › Vehicles are running on a sharp turn or a narrow road.
- › If the vehicle is driving too close to the preceding vehicle, the camera detection scope is hindered.

Functional limitations of the cruise assist

Under the following conditions, the cruise assist system may not take the braking measures:

- › A vehicle suddenly appears in front of you.
- › A vehicle is running at a low speed in front of you when you are driving at a speed of over 60 km/h.
- › An oncoming vehicle is running in the same lane.
- › A vehicle or object that crosses a lane.

Cruise control assist system

- › Pedestrians or animals and small vehicles (such as bicycles and motorcycles) are seen.
- › The vehicle in front decelerates suddenly.
- › Water, snow or mud splashed by surrounding vehicles hinders the sensor detection.
- › The vehicle head tilts up due to overload in the luggage area.
- › The vehicle is running on a winding or narrow road.
- › The preceding vehicle has a relatively small tail dimension or very large ground clearance.
- › The steering wheel operation is unstable or your position in the lane is unstable.

Sensor

The cruise assist system identifies lane boundaries and detects targets through the camera above the front windscreen.

i NOTICE

When the instrument cluster indicates that the system sensor detection is restricted, please check and ensure the camera and its surroundings are clean and free of obstructions so that the system can operate properly.

Intelligent driving assist system

Vehicle equipment



Please note that this manual contains all the standard equipment, country-specific equipment and special equipment for this model series. Thus, some equipment or features described in this manual may not be installed onto your vehicle or are only available in some markets. For further configuration information, please refer to relevant sales information or consult with your distributor selling the vehicle to you.

Intelligent driving assist system sensor

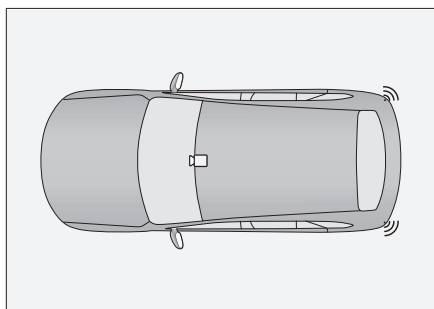
The intelligent driving assist system detects the traffic situations around the vehicle using a camera and radars, and assists the driver in taking appropriate measures based on the detection results to improve safety and comfort while the vehicle is travelling.



5F87552869EB

Illustration	Description	Position
	Camera	Near the base of the inside rear-view mirror
	Millimetre wave radar	Inside the rear bumper

i NOTICE

Due to different vehicle configurations, sensor types and quantities may vary. Please refer to the actual vehicle.

! WARNING

- › The intelligent driving assist system is intended as a supplementary system and is not designed to replace the driver's own assessment of the traffic conditions or to take control of the vehicle. Under any circumstances, the driver should be responsible for the safety of the vehicle and must concentrate on driving carefully at all times.
- › When the vehicle has towing equipment installed or is towing another vehicle, intelligent driving assist system can not work properly, so the function related to the intelligent driving should be turned off.

Intelligent driving assist system

2

Driving

About the camera

The camera is used to identify lane markings, traffic signs, targets in front of the vehicle, etc., providing relevant information for the intelligent driving assist function.

WARNING

- › It is strictly prohibited to disassemble or modify the camera without permission.
- › When the camera does not work properly, the function of relying on the camera to provide lane marking, traffic sign and target information will be limited.
- › The camera has a limited detection scope and cannot detect the targets outside the limit scope.
- › When the camera fails or is damaged, please contact the authorised service centre in time for repair or replacement.

WARNING

Many factors will affect the performance of the camera, resulting in detection performance degradation, detection delay, and detection errors. These factors include but are not limited to the followings:

- › Poor lighting conditions at night;
- › Weather conditions (such as rain, snow and fog) with poor visibility;

- › A situation in which a vehicle wobbles due to an undulating or uneven road;
- › A situation where the ambient light changes sharply;
- › A situation that a strong light shines the camera;
- › Deformed or damaged windscreen, causing the incorrect camera installation position and angle;
- › Complex intersections;
- › Too high or too low ambient temperature;
- › A situation that the camera is covered with a foreign object;
- › Short following distance and blocked camera;
- › A situation where a guardrail, an elevated road or a tree casts a shadow on a road;
- › Poor tunnel light;
- › A situation of passing through narrow bends and sharp turns;
- › Unclear lane markings.

NOTICE

When the instrument indicates that the system sensor detection is restricted, check and ensure the camera and its surroundings are clean and free of obstructions so that the system can operate properly.

Intelligent driving assist system

About the millimetre wave radar

The radar is used to detect the targets at the rear sides of the vehicle, providing relevant information for the intelligent driving assist function.

WARNING

- › It is strictly prohibited to paint and modify the bumper without permission to avoid the limited detection performance of the radar.
- › When the radar cannot work normally, the function relying on the radar to provide detection information will be limited.
- › The radar has a limited detection scope and cannot detect the targets outside the limit scope.
- › When the radar fails or is damaged, please contact the authorised service centre in time for repair or replacement.

WARNING

Many factors will affect the performance of the radar, resulting in detection performance degradation, detection delay, and detection errors. These factors include but are not limited to the followings:

- › Severe weather (e.g. fog, haze, rain, snow and dust storm);
- › Foreign objects such as ice, snow, water, and dust attached to the surface of the radar, or bumper;

- › Misaligned or blocked radar;
- › The impact to the area around the radar and the bumper due to the collision of vehicles, scratches and other accidents;
- › Too small volume of the detected object;
- › Interference by electromagnetic wave of the same frequency;
- › The radar temperature is out of the working range due to the vehicle being in a high temperature or extremely cold environment.

NOTICE

The area around the radar and the bumper must be kept clean and free from foreign objects such as ice, snow and dust to ensure the normal operation of the radar.

When you find a foreign object attached to the surface of the radar, wipe it with a soft cloth or clean it with water.

- › Do not use the high-pressure water gun to flush the radar.
- › Do not use sharp or abrasive objects for cleaning.
- › Do not use chemical solvents or abrasive cleaners.

Intelligent driving assist system

2

Driving

Front assist system

The front assist system identifies vehicles on the lane via a camera on the front windscreen. When the risk of collision ahead is detected, the system will issue an alarm or conduct the braking intervention to mitigate the consequences of the accident.

After starting the vehicle, you can set the functions related to front assist through the **【Vehicle Setting】** → **【Intelligent Driving】** → **【Front Assist System】** interface on the multimedia display screen.

⚠ WARNING

- › We cannot guarantee that this system will function as expected in all situations. Driving the vehicle towards pedestrians, animals or other vehicles for the purpose of testing the system is strictly prohibited. Failure to comply may result in serious injuries or death.
- › In complex driving conditions, the system may apply unnecessary braking. This may happen, for example, in construction sites, at railway tracks, and when water is sprayed or splashed in front of the vehicle.
- › This system may not work or may not work properly in low-visibility situations (such as rain, snow or fog, and at night).

Automatic emergency braking (AEB)

The automatic emergency braking system includes forward collision warning system and brake assist function.

For driving forwards, this function will detect the risk of collision between your vehicle and pedestrians, cyclists and vehicles (most stationary vehicles or the vehicles driving in the same direction in the same lane as your vehicle) ahead in a limited range, and actively send visual warnings and audible alarms, as well as try to actively brake to reduce driving speed, minimizing the impact of forward collisions and improving the safety performance of driving vehicles.

- › Off: all automatic emergency braking functions are off.
- › Braking: the automatic emergency braking function is on.

Forward collision warning

When the vehicle speed is within the system working range, the system will give visual warnings, and audible alarms to remind the driver to take safe driving measures in time if it detects a pedestrian or vehicle and determines that there is a risk of a collision.

Alert messages include:

- › Images and texts on the instrument panel.
- › Audible alarms.
- › Sudden braking.

Intelligent driving assist system

Brake assist

When the vehicle speed is within the system working range, the system will control the vehicle to automatically perform emergency braking to avoid collisions to the greatest extent if it detects that there is a collision risk with a pedestrian or a vehicle and that the driver does not take safe driving measures within a limited range. However, if a collision is inevitable, the system will minimize the vehicle speed to avoid collisions, and will send out images and audible alarms to alert the driver. Meanwhile, the hazard warning lights flash quickly to remind the rear vehicles, lowering the risk of rear-end collision by the rear vehicles.

Brake assist can also address the potential risks to a certain extent when the vehicle is turning at a crossroad. With your vehicle speed within the system working range when the vehicle is making a turn at a road junction, the system will control the vehicle to automatically perform braking to avoid collisions to the greatest extent if it detects that there is a collision risk with a pedestrian or a vehicle in the opposite direction within a limited range. The vehicle will send images and audible alarms to remind the driver.

Meanwhile, the hazard warning lights flash quickly to remind the rear vehicles, lowering the risk of rear-end collision by the rear vehicles. The system can detect pedestrians and vehicles (passenger cars, lorries, buses, etc.) from the opposite direction of your vehicle to a limited extent.

When the system is working, the following alarm messages will be issued:

- › Images and texts on the instrument panel.
- › Audible alarms.

WARNING

- › The working range of the automatic emergency braking system is about 5 to 150 km/h.

Intelligent driving assist system

2

Driving

- › The automatic emergency braking system is an emergency collision assist function. For safety reasons, drivers are strictly prohibited from consciously driving to pedestrians, cyclists and vehicles to test the automatic emergency braking function.
- › The automatic emergency braking system is an emergency collision assist function, which is not designed to completely prevent collisions. The system only minimizes the impact of a forward collision by trying to reduce the driving speed within a limited range when the vehicle is at risk of an emergency collision. Please do not rely excessively on the automatic emergency braking system to avoid serious personal injury and property damage.

- › The automatic emergency braking system is limited by several factors and cannot be a substitute for the driver's accurate braking. Meanwhile, the system cannot meet the requirements of accurate functions in all driving states, environments, weather, and road conditions. The system may cause the vehicle to perform unnecessary alarms and braking or omit alarms and brakes. It is necessary to always focus all attention when driving and prepare to take braking and/or turning measures to avoid collisions. Do not rely solely on the automatic emergency braking system to avoid collisions or reduce the impact of collisions.
- › The automatic emergency braking system cannot be a substitute for maintaining the safe driving distance between your vehicle and a pedestrian, cyclist, and vehicle in front. Please avoid driving too close to the above targets or having radical driving behaviour.
- › When the automatic emergency braking system is turned off, the vehicle will not warn or perform braking even if it detects potential hazards. It is recommended that you do not deactivate this function. This function will restart after the vehicle is powered on again.

Intelligent driving assist system

⚠ WARNING

The conditions below may cause the automatic emergency braking system to fail to brake, interrupt braking, or reduce braking capacity, including but not limited to the following:

- › The R gear position is engaged.
- › The electronic stability control (ESC) system is not activated or is limited.
- › The brake function cannot fully work (supercooled, overheated and wet brake parts, improper vehicle maintenance, excessive brake or tyre wear, abnormal tyre pressure, etc.).
- › The sensor detection is limited or malfunctioning (e. g., sensor sheltered, and surface dirty).
- › The driver is not wearing a seat belt.
- › The front doors are not closed.
- › The driver has been already braking.
- › The driver depresses hard or urgently on the accelerator pedal.
- › The driver turns the steering wheel quickly.
- › The driver turns on the turn signal light incorrectly in the case of the failure to comply with the traffic regulations when turning at an crossroad.
- › The automatic emergency braking cannot be triggered again within about 20 seconds after triggering.
- › No vehicles, cyclists or pedestrians are detected ahead.

- › The vehicle is driving on snow-covered, slippery, gravel or desert roads.

⚠ WARNING

- › The automatic emergency braking system may not completely bring the speed to a standstill when it is activated. Please be prepared to take over the control of the vehicle at any time if the system interrupts braking.
- › If the driver depresses the accelerator pedal and brake pedal or intervenes by steering during emergency braking, the system will exit emergency braking function. The driver should be ready to take over the control of the vehicle at any time.
- › During the automatic emergency braking, the brake pedal will automatically and quickly go down. Please do not place your foot under the brake pedal to prevent injury, or put anything under the brake pedal to affect braking.

Intelligent driving assist system

2

Driving

- › When the automatic emergency braking system is activated, if the vehicle speed is low, the system will be able to reduce the speed until it comes to a complete stop so as to avoid a potential collision, but it will not keep the vehicle stationary continuously. Now the driver should actively apply the brakes. If the vehicle is stationary, the system will activate the electronic parking brake to stabilize the vehicle when it stops. If you want to continue driving, release the electronic parking brake, or depress the accelerator pedal hard or actively turn the steering wheel.
- › The warning function of the automatic emergency braking system is for the driver's reference only and cannot be a substitute for the driver's own attention and judgement. When the system sends out visual texts, pictures, and sounds, please take immediate collision avoidance measures to remove potential risks. Do not rely on the automatic emergency braking system to intervene in braking the vehicle.

- › The automatic emergency braking system only assists you in safe driving. The system is affected by several factors. Please keep yourself focused, abide by the current traffic laws and regulations, and drive safely. You always bear the ultimate responsibility for safe driving.

WARNING

The operations below may cause the automatic emergency braking system to fail to give an alarm or interrupt an alarm, including but not limited to the following:

- › The automatic emergency braking system may not sound an alarm when the driver has been already braking.
- › The automatic emergency braking system may fail to sound an alarm or interrupt an alarm when the driver steps on the accelerator pedal deeply or sharply.
- › The automatic emergency braking system may fail to sound an alarm or interrupt an alarm when the driver turns the steering wheel quickly.

Intelligent driving assist system

⚠ WARNING

The function of the automatic emergency braking system may be limited, and the targets that make the automatic emergency braking system limited or inoperative, include but are not limited to:

- › Oncoming vehicles and motorcycles.
- › Crossing vehicles and motorcycles.
- › Vehicles and motorcycles parked horizontally, obliquely and opposite.
- › Special-shaped vehicles (tractors, mud trucks, etc.).
- › Unconventional small wheeled vehicles (strollers, suitcases, shopping carts, wheelchairs, etc.).
- › Unusual means of transportation (carriages, ox carts, etc.).
- › Traffic lights, warning signs, and roadblocks (cone barrels, etc.).
- › Trash bins, cartons, and parcels.
- › Walls, stones, and road edges.
- › Flying or falling objects.
- › Animals.
- › Other non-vehicle objects.

⚠ WARNING

The associated cameras and millimetre-wave radar sensors that the automatic emergency braking system relies on have limited detection capabilities, which may result in non-essential alarms and brakes or missed alarms and brakes, including but not limited to the following:

- › The system may not recognize stationary targets at high vehicle speeds.
- › A vehicle (especially a bus, truck, etc.) closely cuts in front of your vehicle.
- › The targets are partially blocked by obstacles, pedestrians, vehicles or other objects, etc.
- › A vehicle is driving on a slippery, cornering and hillside road.
- › The vehicles with trailers, tractors, mud trucks, and special-shaped vehicles appear in front.
- › The front windscreen area within the camera's field of view is blocked by dirt, tags, etc.
- › The visibility is limited by weather conditions (fog, haze, rain, snow, dust storm weather, etc.).
- › A vehicle is driving in a dark surrounding area (at dawn or dusk, at night, driving in a tunnel, etc.).
- › The detected target colour is almost the same as the surrounding environment colour.

Intelligent driving assist system

- › A strong light shines on the camera, or the light intensity abruptly changes.
- › There are sudden changes in ambient brightness (strong light, back-lighting, etc., when entering and exiting the entrance and exit of the tunnel).
- › Other radar or camera detection capabilities are limited.
- › Low: the system will give an alarm reminder when your vehicle is close to pedestrians or vehicles ahead.
- › High: the system will give an alarm reminder when your vehicle is far from pedestrians or vehicles ahead.

Lane assist system

The lane assist system is designed for vehicles driving on highway and other roads in good condition. It can identify lane boundaries via a camera on the front windscreen and alert drivers to correct their route if they unconsciously deviate from their lane. Also, it even assists the driver to correct direction to mitigate accident consequences with some of its functions.

After starting the vehicle, you can set the lane assist-related functions through the **【Vehicle Setting】** → **【Intelligent Driving】** → **【Lane Assist System】** interface on the multimedia display screen.

⚠ WARNING

The above warnings, reminders and restrictions do not cover all the conditions that may affect the normal working of the automatic emergency braking system. More factors can interfere with the automatic emergency braking system. Drivers need to concentrate on staying focused, constantly pay attention to the traffic environment, always be ready to take collision avoidance measures and drive safely. Do not rely solely on the automatic emergency braking system to avoid collisions or reduce the impact of collisions.

Front collision warning sensitivity

Front collision warning sensitivity is divided into three levels.

- › Standard: the system will give an alarm reminder when the distance between your vehicle and pedestrians or vehicles ahead is set to the normal value by the system.

⚠ CAUTION

The lane assist system properly works only when the lane boundaries are clearly visible. It may not work properly or even not work in some cases. For example:

- › Lane boundaries are unclear, non-standard, or otherwise obscured.
- › There are objects on the road that affect the identification of lane boundaries (water, cracks, ruts, signs, crosswalks, bumps or pits, etc.).

Intelligent driving assist system

- › There is low visibility (rain, snow, fog and haze, night, etc.).
- › The vehicle is strongly affected by the crosswind.
- › The lanes merge or separate.
- › A strong light shines on the camera, or the light intensity abruptly changes.
- › The front windscreen around the camera is dirty, frozen, damaged or covered.
- › The vehicle is running on a sharp turn, a narrow road, or a road prone to rollover.
- › Your vehicle is running too close to the preceding vehicle, and the camera detection scope is hindered.

i NOTICE

- › If you turn on the turn signal lights, turn the steering wheel, depress the accelerator pedal or the brake pedal before passing through a lane boundary, the system will not send an alarm. In this case, the system considers you attempt to drive the vehicle.
- › When the driver controls the steering wheel with a small force, the system may not detect the driver's hand holding the steering wheel, and the instrument panel will send an alarm.

Lane assist function

When the lane assist function is activated, the assist type can be selected.

- › Warning assist: it can warn the driver to drive safely when the driver deviates from the lane unconsciously.
- › Lane keeping assist: it can assist the driver to correct the steering wheel to keep the vehicle in the lane when the driver deviates from the lane unconsciously. If the correction fails, the system will give an alarm to alert the driver to drive safely.
- › Lane center assist: it can assist the driver to correct the steering wheel to control the vehicle to drive in the centre of the current lane. If the correction fails or the vehicle is off the current lane, the system will give an alarm to alert the driver to drive safely.

i NOTICE

The lane assist function can only work when the vehicle speed is within 60 to 150 km/h.

When the lane assist function is turned on, the lane boundaries will be displayed on the instrument panel.

- › Grey: it indicates that the system fails to detect a lane boundary.
- › White: it indicates that the system detects a lane boundary.
- › Green: it indicates that the system is correcting the steering wheel.

Intelligent driving assist system

2

Driving

- › Red and flashing: it indicates that the system sounds an alarm, and the driver needs to correct the direction in time to make the vehicle return to the lane.

i NOTICE

The lane center assist functions only when the system identifies the lane boundaries on the left and right sides.

Emergency lane keeping

When the emergency lane keeping is activated, the system will more actively correct the steering wheel in case of an emergency to reduce the risk of collision. For example: when the driver is unaware of lane deviation or turns on the turn signal light to change lanes, there is a risk of collision with the oncoming vehicle in the adjacent lane or a vehicle from the rear in the same direction, or there is a curb or a pit outside the lane.

i NOTICE

The emergency lane keeping function can only work when the vehicle speed is within 60 to 150 km/h.

! WARNING

In some cases, the emergency lane keeping function may not work properly or not work. For example:

- › For smaller targets (motorcycles, bicycles, etc.).
- › For stationary targets.

- › The current vehicle is moving too close to the preceding vehicle and prevents the camera from detecting it.
- › The rear vehicle is driving too close to the current vehicle and prevents the sensor from detecting it.

Smart dodge function

After the smart dodge function is turned on, when the lane center keeping function or intelligent cruise control assist mode is turned on and in working condition, and the system identifies that the vehicle speed is higher than that of the large vehicle (wagon, truck, bus, etc.) at the adjacent lane, it will control the vehicle to move slightly away from the large vehicle. After overtaking the large vehicle, your vehicle will return to the central area of the current lane.

i NOTICE

The smart dodge function will not begin to work until the vehicle speed reaches 60 to 140 km/h.

! CAUTION

The following situations may not trigger the smart dodge function:

Intelligent driving assist system

- › The system detects that there is a large vehicle on the adjacent lane on one side, and there are vehicles on the adjacent lane on the other side, or the adjacent lane on the other side is a curb.
- › The vehicle is driving in severe weather such as night, heavy fog, rain and snow.
- › The vehicle is in a curve.

Warning modes

There are three warning modes: sound, vibration, and sound + vibration.

Sensitivity

Sensitivity is divided into three levels: Low, standard and high.

Side assist system

The side assist system can detect vehicles behind your vehicle or in the adjacent lane through sensors on both sides of the rear bumper. If there is a risk of collision, the system will issue an alarm to remind the driver to drive safely.

After starting the vehicle, you can set the functions related to side assist through the **【Vehicle Setting】** → **【Intelligent Driving】** → **【Side Assist System】** interface on the multimedia display screen.

i NOTICE

- › Keep both sides of the rear bumper clean, do not paste any objects and do not cover them with ice, snow, mud and other foreign objects, so as not to affect the normal work of the sensor.
- › Improper repair or modification of the vehicle may cause the sensors to be dislocated, which may affect the proper operation of the side assist system. Therefore, it is recommended that you maintain and repair your vehicle at the authorised service centre.
- › Turn off the side assist system when towing other vehicles.

⚠ WARNING

In some cases, it may not work properly or even not work. For example:

- › For stationary targets (such as vehicles and pedestrians).
- › Driving in adverse conditions such as rain, and snow.
- › Driving on sharp turns, slopes, very wide or narrow lanes.

Intelligent driving assist system

Warning lights



5E7DEC5EAC94

The warning lights are located on the surfaces of the left and right side mirrors.

⚠ WARNING

Do not paste any objects on the warning lights to avoid affecting the system's alarm function.

Blind spot monitoring

During driving (with the vehicle speed above 12 km/h), when the system detects a vehicle in the blind area of the side mirror or an approaching vehicle behind the adjacent lane, the warning light on the corresponding side will go on. If you turn on the turn signal light at the same side at this time, the warning light will flash accompanied by an audible alarm, prompting you that it is dangerous to continue to change the lane.

Door open warning

When the system detects that there are approaching vehicles and bicycles and other targets in the adjacent lanes on both sides after the vehicle stops and that there is a risk of collision when the door is opened, the warning light at corresponding side will go on. If the passenger continues to open the door at this time, the warning light will flash accompanied by an audible alarm, prompting you that it is dangerous to continue to open the door.

The door open warning system will only function in the following conditions:

- › The vehicle power supply is in ON mode.
- › It is within 3 minutes of switching the power supply mode from ON to OFF mode.

i NOTICE

When the setting value of the power saving delay function is less than 3 minutes, it will be executed according to the power saving delay setting.

2

Driving

Intelligent driving assist system

Rear crash warning

When the system detects that there is a fast approaching vehicle behind the subject vehicle and there is a risk of collision, the left and right indicators will flash quickly, accompanied by an audible alarm to remind the driver of the subject vehicle that a dangerous target is approaching, and warning the driver of rear vehicle to drive safely.

Rear cross traffic alert/brake

When the rear cross traffic alert function is enabled, if during reversing the system detects that there is a risk of collision with a moving vehicle in the blind area of the side mirror, it will give an alarm to remind the driver to drive safely.

When the rear cross traffic brake function is enabled, limited braking can be applied when there is a risk in reversing to reduce the risk of collision.

i NOTICE

When the vehicle is started and the R gear position is engaged, the rear cross traffic assist function is working.

⚠ CAUTION

The rear cross traffic assist function is limited in some cases. For example,

- › There are obstacles blocking. The system cannot detect objects behind other parked vehicles or obstacles.

- › The current vehicle speed is too high or too low.
- › The driver depresses the accelerator pedal firmly.
- › The driver turns the steering wheel quickly.

Traffic sign information

The traffic signs information function is used to recognize the traffic signs through the camera on the front windscreen and display them on the instrument cluster to give a prompt to the driver.

After the vehicle is started, the functions related to traffic sign recognition can be set through the **【Vehicle Setting】** → **【Intelligent Driving Setting】** → **【Traffic Sign Information】** on the multimedia display screen.

Traffic sign recognition

The traffic signs are recognized by the camera on the front windscreen and displayed on the instrument cluster to prompt the driver.

Overspeed warning

After the speed limit sign is recognized, in case of overspeed, the system will give an alert to remind the driver to reduce the speed to a suitable range as soon as possible.

Intelligent driving assist system

Overspeed warning sensitivity

The warning timing for overspeed can be set according to your driving habits.

- › 0: a warning will be given when the vehicle speed reaches the speed limit.
- › > 0: a warning will be given only when the vehicle speed exceeds the speed limit.
- › < 0: a warning will be given in advance when the vehicle speed does not reach the speed limit.

Cruising speed limit

After turning on traffic sign recognition, you can enable the cruising speed limit function.

When the vehicle is running in a cruise mode, if a speed limit sign of ≥ 30 km/h is recognised and the vehicle speed is above the speed limit, the system will prompt the driver whether to adjust the speed. After the driver confirms, the speed will be controlled within the speed limit allowed by the speed limit sign.

⚠ WARNING

- › The traffic sign information function is only intended to remind the driver to pay attention to traffic signs. It is not suitable for all situations and cannot take the place of the driver's judgement regarding roadside speed limit information.

- › In any case, the driver should be responsible for the safety of the vehicle, and must always drive carefully and abide by the applicable laws and road traffic rules.

⚠ CAUTION

The traffic signs information function can work properly only when the speed sign is clearly visible. It may not work properly or even not work in some cases. For example:

- › A sign fades.
- › A sign is on a curve.
- › A sign is not properly positioned.
- › A sign is rotating or is damaged.
- › A sign is fully or partially blocked.
- › A sign is fully or partially covered by frost, snow, dust, etc.
- › A speed sign is placed in the position that is too far or too high.
- › A speed limit reminder or sign is attached to the road surface.
- › There is low visibility (rain, snow, fog and haze, night, etc.).
- › A strong light shines on the camera, or the light intensity abruptly changes.
- › The front windscreen around the camera is polluted, damaged or covered.
- › Your vehicle is running too close to the preceding vehicle, and the camera detection scope is hindered.

Intelligent driving assist system

- › The vehicle speed is too low.

i NOTICE

- › The speed limit sign identified by the system shows the default speed unit of km/h.
- › For multiple speed limit values on the same speed limit sign, the system will show the maximum value.
- › When multiple speed limit signs are arranged in parallel, the system will display the maximum speed limit value. Take the actual speed limit value of the current lane as the criterion.
- › The system may not be able to recognise a speed limit sign when the vehicle is turning.

Off-road cruise control assist system

Vehicle equipment

Please note that this manual contains all the standard equipment, country-specific equipment and special equipment for this model series. Thus, some equipment or features described in this manual may not be installed onto your vehicle or are only available in some markets. For further configuration information, please refer to relevant sales information or consult with your distributor selling the vehicle to you.

Off-road cruise

Function introduction

The off-road cruise function allows you to keep the vehicle moving at a set speed without having to press the accelerator or brake pedal. It can be used when the vehicle is in 4L mode and D gear or M gear is engaged and you drive at low speeds in off-road conditions or on bumpy roads, or when the vehicle is out of trouble.

i NOTICE

As the off-road cruise is designed for off-road driving, the cruise speed is 4 to 12 km/h.

! WARNING

- › Off-road cruise is only an auxiliary tool. It is not a substitute for the driver's judgement on road and traffic conditions. Nor can it replace the driver's driving. In any case, the driver shall be responsible for the safety of the vehicle and must concentrate on driving carefully at all times.
- › Improper use of the off-road cruise may result in a crash.

If off-road cruise is used continuously for a long period of time, some systems may overheat. At this point, a warning message will be displayed on the multi-information display and the off-road cruise indicator  will go out. In this case, park the vehicle in a safe place immediately and shut off the engine to cool some systems.

- › When the single-sided wheels slip while the vehicle is in off-road cruise operation, lock the front and rear axle differential locks in time.

! WARNING

In some cases, off-road cruise may not be able to maintain a constant low speed, which may lead to an accident. For example:

- › A steep slope.
- › Extremely uneven roads.
- › Snow, icy roads, or other wet and slippery roads.

Off-road cruise control assist system

⚠ CAUTION

The off-road cruise function is not available for use when the vehicle is at a high speed.

Turning on and off the system

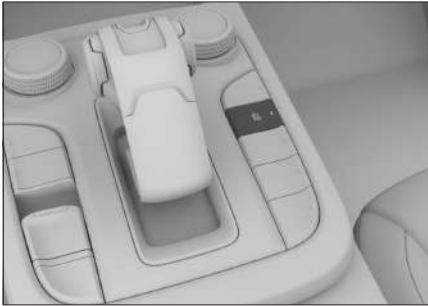



Press the button  on the auxiliary instrument panel to turn on or off the off-road cruise function.

i NOTICE

To turn on the off-road cruise, the following conditions must be met:

- › The driver side door is completely closed.
- › The engine is started and the N gear is engaged.
- › The vehicle is in 4L mode.
- › Release the parking brake.

After off-road cruise is turned on, the off-road cruise indicator  on the instrument cluster turns on.

- › The off-road cruise indicator  lights up in white to indicate that the function is turned on and that the off-road cruise system is ready for use.
- › The off-road cruise indicator  lights up in green to indicate that the function has been activated. After turning on the function, shift to D or M gear to activate the function, and the off-road cruise function will go into cruising state automatically.

Cruise speed setting

There are 9 cruise speed gears, which can be set and displayed in the multi-information display in the following way.

- › Move the control lever directly up or down.

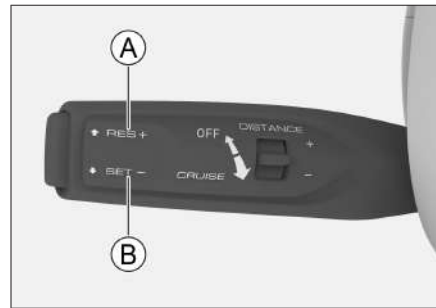

- (A) Acceleration
- (B) Deceleration

- › Depress the accelerator or brake pedal, adjust the vehicle to the desired speed and release the pedal.

Off-road cruise control assist system

i NOTICE

When the cruise speed exceeds 20 km/h, the off-road cruise enters standby mode; when the cruising speed exceeds 35 km/h, the off-road cruise is automatically switched off.

Refer to some typical road conditions and recommended off-road cruise gears listed below:

Off-road cruise gears (reference values)	Road conditions
Gear 1 ~ Gear 2	Rocky road, bumpy road (downward slope), cross-axis road, etc.
Gear 3 ~ Gear 4	Bumpy road (upward slope), gravel road (downward slope), etc.
Gear 5 ~ Gear 6	Snow, mud, gravel road (flat road or upward slope), etc.
Gear 7 ~ Gear 9	Sand, mud, grassland, integrated cross-country road, etc.

Turn assist

Turn assist function can be triggered when the off-road cruise assist system is in use, and it can improve the off-road performance, effectively reduce the turning radius, and thus improve the turn performance while maintaining the set vehicle speed.



How to use

When the off-road cruise is turned on, press the button  to turn on or off the turn assist function.



F594FB8C17E5

When the turn assist is turned on, the turn assist indicator  on the instrument cluster lights up.

- › The turn assist indicator  lights up in white to indicate that the function is turned on and that the turn assist is in the standby status.
- › The turn assist indicator  lights up in green to indicate that the function is activated and that the turn assist is in cruise operation status.

! CAUTION

The following basic conditions must be met in order to activate the turn assist function:

- › The vehicle is currently in the off-road cruise activation state.
- › The rear axle electric differential lock is not locked.

Off-road cruise control assist system

- › The steering wheel is fully turned (turn the steering wheel fully counterclockwise or clockwise to the end).
- › The accelerator pedal and brake pedal are not pressed deeply.

i NOTICE

The effect of turn assist function is best when the vehicle is cruising under the minimum speed.

The turn assist function goes into standby status when the off-road cruise speed exceeds 10 km/h; when the off-road cruising speed exceeds 30 km/h, the turn assist function is automatically switched off.

⚠ CAUTION

Do not use the turn assist function on paved roads or streets (normal roads, concrete roads, etc.) as this will cause abnormal tyre wear.

Hill descent control system (HDC)

Vehicle equipment

Please note that this manual contains all the standard equipment, country-specific equipment and special equipment for this model series. Thus, some equipment or features described in this manual may not be installed onto your vehicle or are only available in some markets. For further configuration information, please refer to relevant sales information or consult with your distributor selling the vehicle to you.

Hill descent control system introduction

While going downhill, the hill descent control system (HDC) may actively brake to ensure that the driver can maintain a constant speed and drive downhill safely.

⚠ WARNING



- › HDC is intended only to be an aid. At all times the driver should be responsible for the safety of the vehicle, and always pay attention to the surrounding traffic.
- › In case of a very steep slope, the HDC may not function and thus the vehicle can't be driven down the slope at a constant speed. At this time, you can control the vehicle speed by stepping on the brake pedal.

Instructions



B8CCB9A81DFF

When the power supply is set to ON mode or the engine is running, press the button to turn on or off HDC.

- › After HDC is turned on, the HDC indicator light  on the instrument cluster turns on.
- › After HDC is turned off, the HDC indicator light  on the instrument cluster goes off.
- › When HDC is working, the HDC indicator light  on the instrument cluster flashes.

i NOTICE

- › It is recommended that HDC should be used in lower gear position.
- › HDC will be automatically turned off when the vehicle speed is greater than 60 km/h.
- › With HDC turned on, the speed can still be adjusted by pressing the brake pedal or accelerator pedal.

Driving assist system

Vehicle equipment

Please note that this manual contains all the standard equipment, country-specific equipment and special equipment for this model series. Thus, some equipment or features described in this manual may not be installed onto your vehicle or are only available in some markets. For further configuration information, please refer to relevant sales information or consult with your distributor selling the vehicle to you.

Driving assist system safety tips

About traffic safety

Never take a risk in driving because the vehicle is equipped with driving assist systems and always ensure that the vehicle speed and driving style adapt to vision, weather, road and traffic conditions.

About modification

Suspension modification or use of tyres or wheels of non-specified size will impact driving assist systems and may cause system malfunctions.

About sound and vibration

› Some driving assist systems (such as anti-lock brake system) may create a vibration during work or the sound of the motor during working may be heard, which does not indicate a malfunction.

› When the vehicle is started across due to battery loss, the engine may not run smoothly and the anti-lock brake system or electronic stability control system warning light turns on. This is caused by low battery voltage. This does not mean that the anti-lock brake system or electronic stability control system is faulty.

Anti-lock brake system

When brake is applied or the vehicle is braked suddenly during driving on wet and slippery road, the anti-lock brake system (ABS) helps to prevent wheels from locking to maintain steering control of the vehicle.

⚠ CAUTION

During emergency braking, do not step on the brake pedal several times or gently step on it. Otherwise, it will lengthen the braking distance.

The ABS is not designed to shorten the braking distance of the vehicle. Be sure to maintain an adequate safe distance from the vehicle traveling in front as your vehicle may require a longer braking distance, compared with vehicles not equipped with the ABS in the following cases:

- › When driving on muddy, gravel or snowy road.
- › When driving with tyre chains in place.
- › When driving on bumpy road.

Driving assist system

- › When driving on potholes or uneven road.

The ABS may not work effectively in the following conditions:

- › When the limit of tyre grip performance is exceeded (like using excessive wear tyre on snowy road).
- › When driving at a high speed on wet and slippery road.

Electronic braking force distribution system

The electronic braking force distribution (EBD) system is capable of automatically adjusting the front and rear braking force ratio to enhance braking efficiency. It complements the ABS for greater braking stability and thereby vehicle stability.

Braking force assist system

Stepping on brake pedal very quickly can trigger the braking force assist system to help increase the braking effect and shorten the braking distance during emergency braking.

Traction control system

When you start or accelerate on a wet and slippery road, the traction control system (TCS) helps to keep a driving force and avoid driving wheel spinning.

Rollover prevention system

When the vehicle turns a corner, the rollover prevention system (RMI) determines whether there is a risk of rollover by monitoring the movement status of the vehicle. If any, RMI will decelerate one or more wheels to refrain the vehicle from a rollover accident.

Secondary collision mitigation system

The secondary collision mitigation system (SCM) will automatically apply the braking to the vehicle after the first collision (airbag deployment) to reduce the vehicle speed or stop the vehicle, thereby reducing the chance and injury of a second collision.

HHC (Hill-start Hold Control)

When the driver starts on a slope and releases the brake pedal, the hill-start hold control (HHC) can maintain the braking force for about 2 seconds to effectively avoid rolling.

WARNING

When starting on a slope greater than 30%, the vehicle may still roll. Therefore, do not excessively rely on this function. Please pay attention to the safety of the driving.

Driving assist system

Electronic power steering system

The electric power steering system can adjust the power in real time by monitoring the driving speed, so as to ensure the portability of low-speed steering and the stability of high-speed steering and enhance the sense of security.

Electronic stability control system

The electronic stability control (ESC) system can help reduce the risk of side slip, and improve driving stability by braking individual wheel under certain driving situation.

When ESC works, the ESC warning light (yellow)  on the instrument panel flashes. Make sure to be careful at this time.

NOTICE

Generally speaking, the ESC is on throughout the driving process. The system can be turned off only under following special conditions:



- › Drive with tyre chains.
- › Drive in deep snow or on soft ground.
- › The vehicle is stuck and you need to free it.

Activate ESC as soon as you exit above conditions.

Turning on or off the system



8A34C1226EFO

After the vehicle starts, press the ESC OFF button . The ESC OFF indicator light (yellow)  on the instrument panel comes on, indicating that the system is off. Press the button again to restart the ESC system.

NOTICE

The ESC will automatically turn on in the following conditions:

- › Every time you start the engine.
- › The vehicle speed exceeds 85 km/h.

Driving assist system

Dynamic stability assist system

Under the condition that the adhesion coefficients of left and right wheels are quite different (for example, some snow and ice covered roads, wet and slippery roads, etc.), when the vehicle is braked or accelerated urgently, the DST will automatically adjust the steering wheel angle based on the rotational speed difference between the two wheels on the same axis and the dynamic variation of the vehicle, to correct the driving direction of the vehicle.

DST can be turned on or off through the **【Vehicle Setting】** → **【Driving Setting】** → **【Dynamic Stability Assist】** on the multimedia display screen.

i NOTICE

Only when the ESC function is enabled can the DST function be used properly.

⚠ WARNING

› The dynamic stability assist system is only an auxiliary tool. It cannot replace the driver's judgement on road and traffic conditions, and cannot replace the driver. In any case, the driver shall be responsible for the safety of the vehicle and must concentrate on driving carefully at all times.

› When the dynamic stability assist system is working, the steering wheel angle is automatically adjusted only within a limited range. The driver needs to actively adjust the steering wheel angle to ensure correct direction of driving, depending on actual driving conditions.

Emission control system

Vehicle equipment

Please note that this manual contains all the standard equipment, country-specific equipment and special equipment for this model series. Thus, some equipment or features described in this manual may not be installed onto your vehicle or are only available in some markets. For further configuration information, please refer to relevant sales information or consult with your distributor selling the vehicle to you.

Reminder

The emission control system may vary with different engine models. For the particular equipment, please refer to the actual vehicle.

Do not modify any part of the engine or emission control system.

Oxygen sensor

The oxygen sensor measures the concentration of oxygen in the exhaust gases and reports that information to the ECU in order to regulate the engine's fuel-air ratio for optimum combustion efficiency and to reduce the amount of carbon monoxide, hydrocarbons, and nitrogen oxides contained in the exhaust.

Catalytic converter

The catalytic converter is the most important external purifier installed in the vehicle's exhaust system. The catalytic converter contains metallic catalysts that convert harmful gases such as carbon monoxide, hydrocarbons, and nitrogen oxides into harmless carbon dioxide, water, and nitrogen through oxidation and reduction reactions.

As long as the catalytic converter is used correctly, it generally does not require maintenance. Thus, it should not be disassembled without cause. If replacement is necessary, please contact the service provider.

CAUTION

To avoid damaging the catalytic converter, please pay attention to the following items:

- › Do not use leaded gasoline or gasoline with more than the standard amount of manganese or sulphur.
- › Do not drive a vehicle with extremely low fuel level. If the fuel is exhausted, it will cause the engine to misfire (this may be confirmed by unstable engine operation or a loss of power), damaging the catalytic converter.
- › Do not idle the engine at a high speed for an extended time (5 minutes or longer).

Emission control system

- › When a problem with the engine is indicated (such as shutdown or performance degradation), please do not continue driving the vehicle.
- › Do not operate the engine with the spark plugs removed.
- › Do not start the vehicle by pushing or pulling it.
- › Do not add too much engine oil.
- › Please avoid striking the catalytic converter.

Turbocharger

The turbocharger can improve fuel efficiency of the engine, improve the vehicle's power and performance, and reduce the displacement of harmful compounds such as particulates and nitrogen oxides in the engine exhaust.

Fuel evaporation control unit

When the vehicle is running normally, the fuel evaporation control unit can make the fuel steam enter the engine to burn, so as to prevent the fuel steam from entering the atmosphere.

Crankcase emission control unit

The crankcase emission control unit guides the mixed gases within the crankcase (such as uncombusted fuel vapours, water vapour, and exhaust) through a connected pipe into an appropriate place in the air-intake pipe to return them to the cylinders and be combusted again. Thus, the exhaust gas can be reduced while the engine fuel economy improved.

On-board diagnostic system

The engine system malfunction warning light is part of the vehicle's on-board diagnostic system.

The engine electronic control unit equipped with the on-board diagnostic system stores various fault information (especially when it comes to exhaust-emissions fault information). The fault information will be cleared if the battery cables are disconnected, making a rapid diagnosis difficult. Therefore, do not disconnect the battery cable when checking the cause of the engine system malfunction warning light illumination.

Emission control system

Gasoline particulate filter

Function introduction

The gasoline particulate filter (GPF) is part of the vehicle's exhaust gas emission reduction system. It can capture small particles before they enter into the atmosphere, reducing atmospheric pollution.

WARNING

Flammable materials are not allowed to be added to the exhaust pipe, gasoline particulate filter or heat shield as heat will be generated during regeneration process. Otherwise, it can lead to fire accidents.

Regeneration procedure

During driving, when the GPF reaches certain conditions, the vehicle automatically initiates a regeneration procedure when the driving conditions are met. At this point, the instrument will display the prompt 【“GPF is regenerating”】. The regeneration procedure will burn the particulate matter sufficiently to keep the GPF in a stable and efficient working state.

During regeneration process, it is recommended that the vehicle be driven in accordance with the following conditions until the alarm prompt message is cleared, and regeneration procedure is completed. (For ease of viewing, do not hide this alarm prompt message during this procedure)

- › Try to drive at a constant speed on a road with good conditions, while keeping gear in gear 3 and above and at a speed greater than 80 km/h.
- › Avoid idling the engine.
- › Avoid stopping the vehicle or shutting down the engine.

CAUTION

- › If the driving condition is not satisfied and the vehicle does not automatically start the regeneration procedure for a long time, a 【“GPF needs to be regenerated”】 alarm prompt will appear on the instrument. At this point, once you have started the engine (the water temperature gauge indicates that it is in the medium or above position), drive the vehicle according to the driving conditions in the regeneration procedure and allow the vehicle to start the regeneration procedure.

Failure to do so may affect the proper operation of the engine and particulate filter, and may result in damage to vehicle components.

Emission control system

2

Driving

- › Gasoline to be filled must meet national regulatory standards. Avoid the use of fuel additives, etc. Prevent the increase of particulate matter or catalyst poisoning due to fuel quality problems.
- › Please replace the engine oil with the specified brand regularly.

WARNING

Please observe all the traffic laws and regulations when performing the automatic regeneration procedure.

NOTICE

Please observe the following recommendations in your daily driving:

- › Avoid long-term or frequent low-speed and full-throttle running of the engine.
- › Avoid long-term or frequent engine idling.
- › Avoid frequent vehicle stopping or engine shutdown.
- › Avoid frequent short-distance driving.

Virtual instrument panel

Vehicle equipment

Please note that this manual contains all the standard equipment, country-specific equipment and special equipment for this model series. Thus, some equipment or features described in this manual may not be installed onto your vehicle or are only available in some markets. For the further configuration information, please refer to relevant sales information or consult with your distributor selling the vehicle to you.

Instrument panel overview

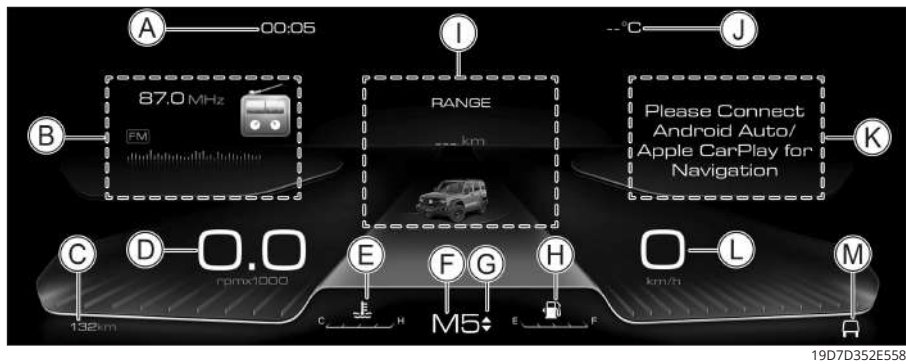

- (A) Digital clock
- (B) Left multi-information display
- (C) Mileage
- (D) Engine tachometer
- (E) Water temperature gauge
- (F) Gear position display
- (G) Gear shift prompt
- (H) Fuel gauge
- (I) Middle multi-information display
- (J) Exterior temperature
- (K) Right multi-information display
- (L) Speedometer
- (M) Driving mode

Water temperature gauge

It displays the engine coolant temperature.

CAUTION

When the water temperature is close to the red warning zone, slow down and find a safe spot to park your vehicle for inspection as soon as possible, and restart the vehicle after the engine water temperature is normal.

Fuel gauge

It displays the amount of fuel remaining in the fuel tank.

Virtual instrument panel

i NOTICE

- › When you drive for an extended time on a slope or around a bend, the fuel displayed may become unstable as fuel moves around in the tank.
- › When the low fuel warning light  on the instrument panel turns on, you should duly refuel even if the instrument panel shows that the vehicle can travel farther.

Engine tachometer

It shows the current engine speed.

Speedometer

It displays the current speed of the vehicle.

Multi-information display

You can set the display content (driving data, multimedia, etc.) of the left, middle or right multi-information display respectively as required.

i NOTICE

When you activate the lane assist or cruise control assist, you cannot adjust the middle multi-information display.

Gear shift prompt

If the current vehicle speed does not match the gear engaged, the instrument panel will show the gear shifting icon to remind you to select proper gear.

- › ▲ Triangle up symbol: prompt you to upshift.
- › ▼ Triangle down symbol: prompt you to downshift.

2

Driving

Virtual instrument panel

Instrument panel control

Control buttons



Ⓐ Select button

Ⓒ Back button

Ⓑ OK button

Ⓓ Menu button

i NOTICE

If an alarm message is present in the multi-information display during operation, it must be hidden first.

Hiding alarm messages





Press the OK button to hide the currently displayed alarm message.

Press and hold the OK button to hide all alarm messages.

Entering into and exiting from the simple mode

Press and hold the menu button  to enter into or exit from the simple instrument panel mode.





Instrument panel custom setting

1. Press any of the instrument panel control buttons and the currently selected multi-information display will be highlighted.
2. Press the left  or right  button, to switch to the multi-information display to be adjusted.
3. Press the menu button  to call up the multi-function tab bar.
4. Press the left  or right  button to select the function tabs to be displayed in the multi-information display.

Virtual instrument panel

2

Driving

Function tab	Multi-information display status
	Set to display the following information: driving data (running time/tripmeter/average speed), fuel consumption, range, tyre pressure monitoring;
	To display the currently played multimedia information;
	To display navigation information when Apple CarPlay is successfully connected;
	To view currently hidden important alarms and automatically hidden secondary alarms;
	<p>The following settings can be made to the instrument:</p> <ul style="list-style-type: none"> › Speed warning setting: press the OK button to turn on or off the speed warning function. When the speed warning function is enabled, press the up ▲ or down ▼ button to adjust the warning speed. When the driving speed reaches or exceeds the set value, a warning of overspeed will appear on the instrument panel to show an alert to drive safely. › Driving data setting: you can set some of the driving data to be hidden or displayed. › Unit setting: you can set the units corresponding to the fuel consumption, temperature and pressure parameters displayed on the instrument panel. › Maintenance mileage: you can check the mileage of the vehicle to the next maintenance (this information is only used to remind you to maintain your vehicle in time). › You can reset all driving data and restore factory settings.

5. When the content displayed in multi-information display contains several pages or options, press the up ▲ or down ▼ button to turn the page or switch to the current option.
6. Press the OK button to go to the next level of the menu or to confirm the current setting for it to take effect.

Virtual instrument panel

Switching between A and B data interfaces

Driving data and fuel consumption are available in both the A and B data interfaces. Press the OK button to switch between A and B data interfaces when the multi-information display displays driving data or fuel consumption.

- › On the data interface A, the driving data within the current ignition cycle is displayed, and the power supply mode is turned to the OFF position. After 4 hours, the data will automatically reset.
- › On the data interface B, the driving data from the last manual reset to the current time is displayed.

Resetting the driving data

When the multi-information display shows driving data or fuel consumption, press and hold the OK button on the steering wheel to manually reset the corresponding data.

Returning to the previous interface

Press the back button  to return to the previous interface.

Instrument indicator lights

Vehicle equipment

Please note that this manual contains all the standard equipment, country-specific equipment and special equipment for this model series. Thus, some equipment or features described in this manual may not be installed onto your vehicle or are only available in some markets. For further configuration information, please refer to relevant sales information or consult with your distributor selling the vehicle to you.

Instrument indicator lights

NOTICE

- › When the power supply mode is switched to ON, some indicator lights or warning lights will illuminate for a short time, indicating that the system self-test is in progress, which is normal.
- › Due to different vehicle configurations, not all the indicator lights or warning lights on the instrument panel will illuminate.



Primary warning indicator light

If this light turns on, it indicates that the vehicle currently has primary warnings and that at least one primary warning is manually hidden.

WARNING

Do not ignore any warning. Otherwise, serious damage to the vehicle or an accident may be caused.

NOTICE

You can check all current warnings of the vehicle on the warning interface of the instrument panel.



Secondary warning indicator light

If this light turns on, it indicates that there are secondary warnings.

WARNING

Do not ignore any warning. Otherwise, serious damage to the vehicle or an accident may be caused.

NOTICE

- › The secondary warnings will automatically hide after being displayed on the multi-information display of the instrument panel for a few seconds.
- › You can check all current warnings of the vehicle on the warning interface of the instrument panel.

Instrument indicator lights



Left turn signal indicator light

When the left turn signal light is on, the left turn signal indicator light will flash.

When the hazard warning lights are on, the turn signal indicator lights and all exterior turn signal lights will flash together.

⚠ CAUTION

When the turn signal indicator light flashes quickly, it usually means that the turn signal light is damaged. Replace it as soon as possible. Otherwise, other drivers will not see the signal you send.



Right turn signal indicator light

When the right turn signal light is on, the right turn signal indicator light will flash.

When the hazard warning lights are on, the turn signal indicator lights and all exterior turn signal lights will flash together.

⚠ CAUTION

When the turn signal indicator light flashes quickly, it usually means that the turn signal light is damaged. Replace it as soon as possible. Otherwise, other drivers will not see the signal you send.



Light on indicator light

If this light turns on, it indicates that the main light knob is on.



Position light indicator light

If this light turns on, it indicates that the parking lights and the license plate lights are on.



High beam indicator light

If this light turns on, it indicates that the high beam headlights are on.



Auto high beam indicator light

If this light turns on in green, it indicates that the auto high beam function is turned on.

If this light turns on in yellow, it indicates that the auto high beam function is faulty. In this case, manually turn on the high beam or low beam headlights as needed, and go to the authorised service centre as soon as possible for inspection and repair.

Instrument indicator lights



Front fog light indicator light

If this light turns on, it indicates that the front fog lights are on.



Rear fog light indicator light

If this light turns on, it indicates that the rear fog lights are on.



Unfastened seat belt warning light

If this light turns on, it indicates that the driver, the front passenger or the rear passenger doesn't fasten the seat belt.

i NOTICE

Due to different model configurations, your vehicle may not be equipped with a rear passenger seat belt unfastened alarm function.



Door open warning light

If this light turns on, it indicates that the door is open or not fully closed.



Airbag fault warning light

If this light turns on, it indicates that there is a malfunction in the airbag system. In this case, go to the authorised service centre as soon as possible for inspection and repair.



Tyre pressure monitoring system warning light

If this light turns on, it indicates that the tyre pressure is too low or the temperature is too high, accompanied by a voice prompt. At this time, stop the vehicle for inspections and contact the authorised service centre.

If this light flashes for a period of time and turns on, it indicates that the tyre pressure monitoring system fails, accompanied by several voice prompts.

! WARNING

If this light turns on, it indicates that sharp turns or emergency braking should be avoided, and the vehicle should be parked at a safe place as soon as possible where inspection is performed.

Driving a vehicle when the tyre pressure is too low or the tyre temperature is too high will increase the possibility of tyre breakdown, and may even cause serious damage to the vehicle or lead to an accident.

Instrument indicator lights



Parking brake indicator light

If this light turns on, it indicates that the parking brake is applied.

If this light flashes, it indicates that the brake disk temperature is too high or the pavement slope is too large. In this case, there is a risk of vehicle rolling. Depress the brake pedal and stop the vehicle on a flat road as soon as possible.



Parking brake fault warning light

If this light turns on, it indicates that the electronic parking brake is faulty.



Auto vehicle hold indicator light

If this light turns on in yellow, it indicates that the auto vehicle hold function is activated and in standby status.

If this light turns on in green, it indicates that the auto vehicle hold function is activated and in working status.



Anti-lock brake system fault warning light

If this light turns on, it indicates that the anti-lock brake system is faulty. In this case, contact the authorised service centre.

If this light turns on, it indicates that the vehicle can still be braked normally although the anti-lock function is not available.



Brake system fault warning light

If this light turns on, it indicates that the brake fluid level is too low or that there is a malfunction in the braking force distribution system.

In this case, immediately stop the vehicle in a safe spot and contact the authorised service centre. Otherwise, a serious accident may be caused.



Electronic stability control system warning light

If this light flashes, it indicates that the electronic stability control system is working.

If this light turns on, it indicates that the electronic stability control system is faulty.



Electronic stability control off indicator light

If this light turns on, it indicates that the electronic stability control system is off.

Instrument indicator lights

2

Driving



Hill descent control indicator light

If this light turns on, it indicates that the hill descent control system is activated and ready for use.

If this light flashes, it indicates that the hill descent control system is working.



2H indicator light

If this light turns on, it indicates that the vehicle is currently in 2WD mode.



4H indicator light

If this light turns on, it indicates that the vehicle is currently in 4WD mode.



4L indicator light

If this light turns on, it indicates that the vehicle is currently in low-speed 4WD mode.



Front axle differential lock indicator light

If this light turns on in green, it indicates that the front axle differential lock is locked successfully.

If this light turns on in yellow, it indicates that the front axle differential lock is faulty. Go to the authorised service centre in time for inspection and repair.



Rear axle differential lock indicator light

If this light turns on in green, it indicates that the rear axle differential lock is locked successfully.

If this light turns on in yellow, it indicates that the rear axle differential lock is faulty. Go to the authorised service centre in time for inspection and repair.



Steering assist indicator light

If this light turns on in white, it indicates that the steering assist function is activated and ready for use.

If this light turns on in green, it indicates that the steering assist function is in working state.

If this light turns on in red, it indicates that the steering assist function does not work.



Electric power steering system fault warning light

If this light turns on in yellow, it indicates that the power steering effect is reduced, so more force is required to operate the steering wheel. If this light remains on after the vehicle is restarted or after a short running distance, go to the authorised service centre as soon as possible for inspection and repair.

Instrument indicator lights

If this light turns on in red, it indicates that the electric power steering system fails and the assisted power no longer exists. In this case, park the vehicle in a safe place and turn off the vehicle, and then restart the vehicle within several minutes. If the light remains on, go to the authorised service centre as soon as possible for inspection and repair.

WARNING

If this light turns on in red, it indicates that the electric power steering system will stop operation. At this time, you need stronger power to operate the steering wheel to realize the steering function. Go to the authorised service centre as soon as possible for inspection and repair.



High engine water temperature warning light

If this light turns on in red, it indicates that the water temperature of the engine cooling system is excessively high. In this case, stop the vehicle immediately for inspection and repair. Otherwise, the engine may be damaged.



Low fuel level warning light

If this light turns on in yellow, it indicates that the fuel is insufficient.

On slopes or during turning, the light may go on prematurely due to unstable fuel levels inside the fuel tank.

CAUTION

Never drive the vehicle when the remaining fuel level is extremely low. Otherwise, the emission control system and power system may be damaged due to running out of the fuel.



Engine system fault warning light

If the light turns on after the engine is started, it indicates that the engine has a fault that affects emissions. In this case, contact the authorised service centre.

NOTICE

The fuel tank cap not being properly installed may also cause this light to illuminate.

Instrument indicator lights



Engine maintenance warning light

If this light turns on, it indicates that the engine has a fault not related to emissions. In this case, contact the authorised service centre.



Low oil pressure warning light

If this light turns on, it indicates that the oil is insufficient. In this case, park the vehicle in a safe spot as soon as possible and shut down the engine. Otherwise, the engine parts may be seriously damaged. Check the oil level after a few minutes and add oil if necessary. If the oil level is normal and the light is still on, contact the authorised service centre.



Battery charging system warning light

If the light turns on after the engine is started, it indicates that there is a malfunction in the battery charging system. In this case, go to the authorised service centre as soon as possible for inspection and repair.



Transmission overheat warning light

If this light turns on, it indicates that the automatic transmission fluid temperature is too high. In this case, park the vehicle in a safe spot as soon as possible and turn off the engine to allow the transmission to cool down.

If the light stays on after the above handling, contact the authorised service centre.



Intelligent start-stop work indicator light

If this light turns on, it indicates that the vehicle is in an automatic stop state and it meets the automatic starting condition.



Intelligent start-stop warning light

If this light turns on, it indicates that there is a fault in the intelligent start-stop system.



Adaptive cruise control indicator light

If this light turns on in white, it indicates that the adaptive cruise control function is activated and in standby status.

Instrument indicator lights

If this light turns on in green, it indicates that the adaptive cruise control function is activated and the cruise speed is successfully set up.



Adaptive cruise control fault warning light

If this light turns on, it indicates that the adaptive cruise control system is faulty. In this case, do not use the adaptive cruise control function, and go to the authorised service centre as soon as possible for inspection and repair.



Intelligent cruise control indicator light

If this light turns on in white, it indicates that the smart cruise control function is turned on and in standby status.

If this light turns on in green, it indicates the intelligent cruise control function is turned on and the cruise speed is successfully set up.

If this light turns on in red, it indicates that there is a fault in the intelligent cruise control system. In this case, do not use the intelligent cruise control function, and go to the authorised service centre as soon as possible for inspection and repair.



Off-road cruise control indicator light

If this light turns on in white, it indicates that the off-road cruise control function is turned on and in standby status.

If this light turns on in green, it indicates that the off-road cruise control function is turned on and in working state.

If this light turns on in red, it indicates that the off-road cruise control system is faulty. In this case, do not use the off-road cruise control function, and go to the authorised service centre as soon as possible for inspection and repair.



Lane assist indicator light

If this light turns on and the vehicle logo is displayed in white, it indicates that the lane assist function is on.

If this light turns on and the vehicle logo is displayed in yellow, it indicates that the lane assist sensor is blocked. In this case, check whether there are coverings on both sides of vehicle. If any, clear them timely.

Instrument indicator lights

2

Driving

If this light turns on and the vehicle logo is displayed in red, it indicates that the lane assist function is abnormal. In this case, do not use this function, and go to the authorised service centre as soon as possible for inspection and repair.

If this light turns on and the lane boundaries are displayed in white, it indicates that the lane departure warning function is turned on and that the system has detected the lane boundaries.

If this light turns on and the lane boundaries are displayed in red, it indicates that the system has detected the abnormal driving. In this time, the driver needs to correct the direction and return to lane timely.

If this light turns on and the lane boundaries are displayed in gray, it indicates that the system has not detected the lane boundaries.

If this light turns on and the lane boundaries are displayed in green, it indicates that the lane assist function is interfering with the direction.

Power management system

Vehicle equipment

Please note that this manual contains all the standard equipment, country-specific equipment and special equipment for this model series. Thus, some equipment or features described in this manual may not be installed onto your vehicle or are only available in some markets. For further configuration information, please refer to relevant sales information or consult with your distributor selling the vehicle to you.

System description

The power management system can monitor the power consumption of each electrical equipment in the vehicle and allocate the power reasonably to improve the starting performance of the vehicle and extend the service life of the battery.

The power management system mainly has the following functions:

› **Battery monitoring**

The current remaining power and health degree of the battery can be calculated accordingly as the voltage, current and temperature of the battery are continuously monitored by sensors.

› **Sleep power management**

Continuously monitor the power consumption of each electrical equipment during the parking period of the vehicle, and gradually shut down unnecessary electrical equipment according to the battery monitoring information, so as to avoid a large amount of battery discharge and ensure the starting performance of the vehicle.

› **Static power management**

Continuously monitor the power consumption of each electrical equipment when the vehicle is not started up, and gradually shut down unnecessary electrical equipment according to the battery monitoring information, so as to avoid a large amount of battery discharge and ensure the starting performance of the vehicle.

› **Dynamic power management**

Continuously monitor the power consumption of each electrical equipment during the driving of the vehicle, and distribute the power generated by the generator to different electrical equipment as needed. When the generator generates more power than the demand of the electrical equipment, the dynamic power management system will regulate and supply power to the battery to allow it to reach the optimum charging status.

Power management system

i NOTICE

It is impossible for a power management system to go beyond the boundaries of physical laws. Note that there are limits to the power and service life of the battery.

If the vehicle has been parked for a long time, certain convenient functions (such as remote unlocking, mobile APP control function, etc.) may not be available. After starting the vehicle, these functions will be restored.

When the engine is shut down

For example, if you listen to the radio or use other functions of the audio/visual system with the engine off, the battery will discharge.

If the battery power is consumed in such a manner that vehicle startup is affected, a message will be displayed on the multimedia display screen or the instrument cluster. If you want to use these functions normally, please start the engine.

2

Driving

Information you should know

The power supply management system will give top priority to ensuring the starting performance of the vehicle.

In the event of short-distance travelling, and driving in urban areas and under low temperatures, the power consumption will increase, and the generator will supply less power.

If the vehicle is not started, the use of electrical equipment will directly consume the power of the battery because the generator cannot supplement power in this case.

In these situations, the power supply management system will operate to control the power distribution.

Parking the vehicle for a long time

If the vehicle is not driven for several days or weeks, the power supply management system will gradually turn off the electrical equipment or reduce the electrical energy being used by the electrical equipment, so as to reduce the power consumption and maintain the vehicle starting performance for a longer time.

3

Audiovisual system

Safety tips	194
Panel introduction.....	196
Display screen introduction	199
Interface introduction.....	200

Safety tips

Vehicle equipment

Please note that this manual contains all the standard equipment, country-specific equipment and special equipment for this model series. Thus, some equipment or features described in this manual may not be installed onto your vehicle or are only available in some markets. For further configuration information, please refer to relevant sales information or consult with your distributor selling the vehicle to you.

Tips for safety

- › Ensure that your use of any of the system's features does not distract you and thereby interfere with safe driving. Your most important responsibility while driving is for the safety of the drive. You must obey all traffic regulations.
- › During driving, the driver is not allowed to operate the system and must keep the volume of the system at an appropriate level, so as not to affect driving safety due to lack of concentration.
- › This system may only be used in areas permitted by law. Some national or local regulations may prohibit use of the display screen within the driver's field of view.
- › Do not disassemble or modify the system.

- › When a failure occurs, stop using the system and contact authorised service centre. Do not try to repair the system by yourself.

About the use

- › For safety reasons, some functions may not be activated when the vehicle starts to move.
- › Do not press the buttons or knobs on the panel firmly.
- › Do not press the screen forcefully or scratch it with sharp objects.
- › When cleaning the display screen, do not use abrasive wipers or detergent containing organic solvent.
- › Do not strike the screen when image jitter occurs in process of operation.

About the radio

When driving the car, you may not find any radio stations, or you may hear noises or receive different radio signals with same frequency, depending on the environment such as road conditions, weather, etc.

About USB storage devices

Since there are various types of USB storage devices, this system may not be compatible with all USB storage devices.

About Bluetooth

- › Since there are a great number of smartphone brands with different functions, this system may not be compatible with all the smartphones.
- › If you cannot search and find the Bluetooth device name of this system during Bluetooth pairing, restart the Bluetooth on the smartphone and search it again.
- › If Bluetooth cannot be connected, delete the paired device on the smartphone, and pair it again.
- › If Bluetooth does not function properly when in use, disconnect the Bluetooth and reconnect it.

Panel introduction

Vehicle equipment

Please note that this manual contains all the standard equipment, country-specific equipment and special equipment for this model series. Thus, some equipment or features described in this manual may not be installed onto your vehicle or are only available in some markets. For further configuration information, please refer to relevant sales information or consult with your distributor selling the vehicle to you.

Steering wheel button

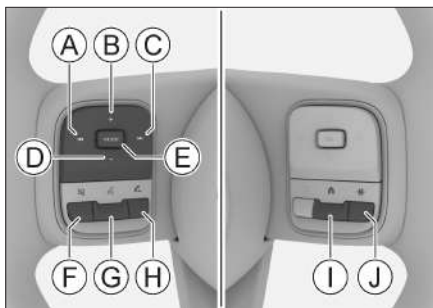

- A Previous radio station/track button
- B Volume + button
- C Next radio station/track button
- D Volume - button
- E Media switching button
- F Mute button
- G Voice button
- H Bluetooth phone button
- I Instrument menu button
- J Custom button

Media switching button

Press the **【MODE】** button to switch between media sound sources.

Voice button

After connecting and turning on Apple CarPlay, press the voice button  to activate or deactivate the voice function.

Bluetooth phone button



Press the Bluetooth phone button  to switch to the Bluetooth phone interface.

Custom button

Press the custom button  to execute the set function. Long press this button to enter the button function setting interface, and you can set the function of this button.

The function of this button can be set in the **【System Setting】** → **【Steering Wheel Key】** interface.

Restarting the system

Press  mute button and  instrument menu button at the same time and hold for about 10 seconds to restart the system.

i NOTICE

- › The audiovisual system and instrument will restart at the same time.
- › Put the vehicle in a safe environment and restart it when it is stopped.

Control panel



- › Touch the ϕ power button to enter standby mode. Press the button again to exit standby mode.
- › Touch the volume $\square++$ or $\square--$ button to adjust the volume.
- › Touch the \square mute button to activate the mute mode. Touch this button again to exit the mute mode.



i NOTICE

- › Ensure a firm connection between the external device and the input port.
- › Do not plug/unplug the device when playing, so as to avoid problems such as the system cannot identify the device.

External devices

USB interface

The USB interface is located in the middle of the instrument panel, as shown in the figure. Connect to the USB device which stores the files supported by this system to play the audio, video and pictures.

Media specifications

This system supports the following media specifications:

Media	Specification
USB device	USB devices with a partition format of FAT16/FAT32/NTFS/ExFAT.
Bluetooth audio	Supports bluetooth 4.2 (bluetooth 4.2, compatible with 2.1 and 3.0, supports low power of bluetooth), and supports Android bluetooth protocol versions: A2DP 1.3, AVRCP 1.6, HFP 1.6, MAP 1.1, PBAP 1.2.

Panel introduction

File format

This system supports the following file formats:

File	Format
Au- dio	MP3, WMA, AAC, AAC Plus, WAV/ WAVE, FLAC, APE, OGG
Vid- eo	MP4, MOV, 3GP, WMV/VC-1, AVI, MPEG, MKV, WebM
Pic- ture	BMP, JPEG/JPG, PNG, GIF, TIFF

3

Audiovisual system

i NOTICE

Even file formats supported by this system may cause non-playback due to file characteristics (such as file quality, bit rate, frame rate, resolution, compression quality, or corruption), playback environment and storage devices.

Display screen introduction

Vehicle equipment

Please note that this manual contains all the standard equipment, country-specific equipment and special equipment for this model series. Thus, some equipment or features described in this manual may not be installed onto your vehicle or are only available in some markets. For further configuration information, please refer to relevant sales information or consult with your distributor selling the vehicle to you.

Display screen status bar

The status bar icons are displayed at the top of the central display screen to display the status of each function. The status bar icons will change in real time according to functional characteristics, signal strength, connection status, switch status, etc.

Icons	Function status
	Time display
	Mute mode on
	Sound mode on
	Bluetooth not connected

Icons	Function status
	Bluetooth connected (the number represents the connected Bluetooth device)
	Power of Bluetooth device 1
	Power of Bluetooth device 2
	Missed calls existed
	Unread messages existed
	Electric steering wheel heater on
	A/C air flow
	A/C blowing mode
	A/C setting temperature
	A/C compressor on
	A/C compressor off

Interface introduction

Vehicle equipment

Please note that this manual contains all the standard equipment, country-specific equipment and special equipment for this model series. Thus, some equipment or features described in this manual may not be installed onto your vehicle or are only available in some markets. For the further configuration information, please refer to relevant sales information or consult with your distributor selling the vehicle to you.

Home

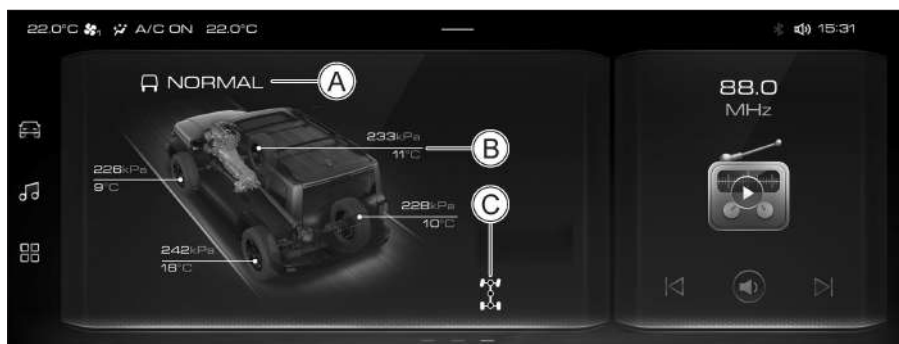

- Ⓐ Driving mode
- Ⓑ Tyre pressure and tyre temperature
- Ⓒ Differential lock status

The application shortcut window is displayed on the homepage, on which the function buttons, status, information and other contents of the application are displayed and can be directly operated and viewed. Slide the screen left and right to turn pages.

Touch any application window for a long time to switch to the edit interface on the homepage, where operations such as adjusting the window size, moving the position, deleting or adding application windows can be performed.

Menu





In most interfaces, tap the menu button  on the left to switch to the menu interface.

Interface introduction



66DF774D8D39

Permanent buttons are displayed on the left and shown in most interfaces for ease of operation.

- › Tap the button < to return to the previous interface.
- › Tap the vehicle setting button  to switch to the vehicle setting interface.
- › Tap the media button  to switch to the media interface.
- › Tap the menu button  to switch to the menu interface.
- › Tap the home button  to switch to the home page.

Apple CarPlay

Connect your Apple phone to the on-board USB port (located in the middle of the instrument panel) via the phone USB cable. Touch the button **【Apple CarPlay】** to switch to the Apple CarPlay interface.

Disconnect the USB cable to exit from the Apple CarPlay.

NOTICE

- › Due to the different compatibilities of mobile phone systems and versions, some iPhones may not support the Apple CarPlay function.
- › When an Apple CarPlay device is connected, the Bluetooth phone function is disabled, and the Apple CarPlay phone function can be used at this time.

Radio

Tap the **【Radio】** button to switch to radio interface. Then you can listen to radio programs.

Interface introduction

i NOTICE

Due to different model configurations and local requirements of countries and regions, radio functions may vary. Refer to the actual vehicle.

Multimedia

Insert a USB device storing files supported by this system into the on-board USB port (located in the middle of the instrument panel) to play USB music, USB videos and USB pictures.

Pair the system Bluetooth with other Bluetooth devices to play Bluetooth music.

Tap the **【Media】** button to play USB music, USB video, bluetooth music, etc.

Tap the button **【Picture】** to view USB pictures.

Bluetooth phone

Tap the **【Bluetooth Phone】** button to switch to the bluetooth phone interface. If no other bluetooth device is connected, pairing and connecting shall be made first. After successful connection, functions such as making and answering calls are available.

System setting

Tap the **【System Setting】** button to switch to the system setting interface, where you can set the audio-visual system sound, display, time, language, etc.

Vehicle setting

Tap the **【Vehicle Setting】** button to switch to the vehicle setting interface, where you can set the function items and switch states of the vehicle.

Shortcut panel

In most interfaces, sliding down from the top of the screen will call up the shortcut panel. The shortcut panel mainly displays system settings shortcut switches, and can be used to customize the position, add or delete shortcut switches.



A54E907B1740

Shortcut switch

The shortcut switches are shown at the top left. Touch the switch to execute or turn on or off the corresponding function. For some switches, touch and hold the switch for a long time to switch to the corresponding setting screen.

Brightness and volume adjustment

The brightness and volume adjustment progress bars are displayed at the bottom left.

- › ☀ brightness progress bar: To adjust the screen brightness.
- › 🔊 volume progress bar: To adjust the volume.

Function card

The right side shows the function cards. Touch the button on the card to execute the corresponding function. For example, enable or disable the corresponding function, switch to the interface of the corresponding function or enable setting window of the corresponding function to pop up.

Touch the edit button  to add or delete a function card. Some function cards cannot be deleted.

Bluetooth phone

In the menu interface, touch the button **【Bluetooth Phone】** to switch to the Bluetooth phone setting interface.

Interface introduction

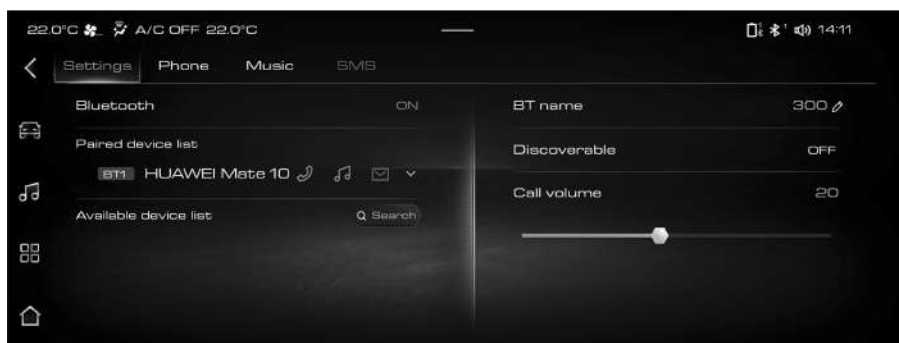

D220170598A1

3

Audiovisual system

- › **【Bluetooth】** : To turn on or off the system Bluetooth.
- › **【Paired Device List】** : To display the paired devices and connection status. The call function can be connected to two mobile phones at the same time, and only one mobile phone can be connected to the music and SMS functions.

i NOTICE

You can delete a paired Bluetooth device in the Paired Device List, meanwhile the contacts, call record and message record stored in the vehicle will also be deleted.

- › **【Other Device】** : Touch the **【Device Search】** button to display the found Bluetooth devices. Touch any Bluetooth device to initiate a pairing and connection request.

i NOTICE

- › To use the contacts, call record and message function, permission shall be granted on the paired and connected phone. Generally, in the process of pairing, a prompt asking for permission will be displayed on the phone.
- › Some devices do not support the SMS function due to system permission restrictions.
- › **【BT Name】** : To display the bluetooth name of this system, which can be modified to a custom name.
- › **【Discoverable】** : When this switch is turned on, other devices are allowed to detect the bluetooth of this system and perform pairing connection; after the count-down is over, this function is automatically turned off.
- › **【Call Volume】** : To adjust the volume of bluetooth phone calls.

Interface introduction

After pairing and connecting the mobile phone, functions such as making calls, answering calls, playing Bluetooth audio and using SMS can be realized.

System setting

In the menu interface, touch the **【System Setting】** button to switch to the system setting interface.

Audio setting

In the system setting interface, touch the **【Audio】** button to switch to audio interface.

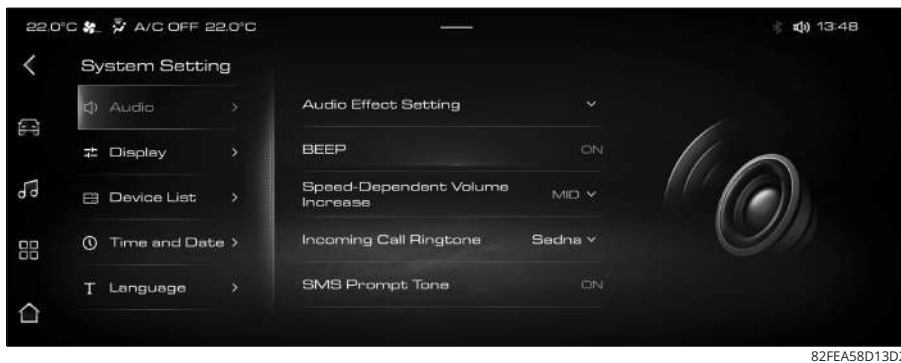

- › **【Audio Effect Setting】** : you can set audio effect, EQ setting, and listening position.
- › **【BEEP】** : when it is turned on, touch or press the button to produce a button audio effect.
- › **【Speed-Dependent Volume Increase】** : the volume will increase appropriately with increasing speed. It can be set to high, medium, low or off.
- › **【Incoming Call Ringtone】** : you can set the ringtone to be played when a bluetooth phone call is coming.
- › **【SMS Prompt Tone】** : when it is turned on, the ringtone will be played when a text message is received.
- › **【Volume Adjustment】** : you can adjust media, BT call, chime, etc.
- › **【Volume Max】** : you can set the default volume.
- › **【Tuner Default Mute Setting】** : when it is enabled, the radio will remain mute each time it is turned on.

Interface introduction

Display setting

In the system setting interface, touch the **【Display】** button to switch to the display setting interface.

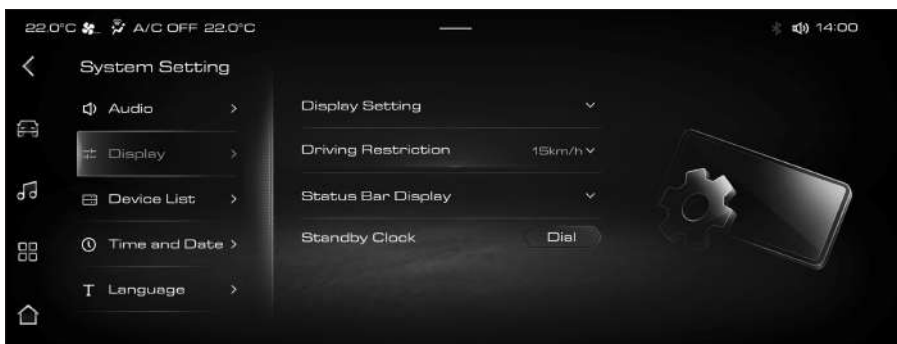

3B204E6BCC5D

- › **【Display Setting】** : after it is expanded, you can set the display mode (day, night or auto) and display brightness (cluster brightness, HUT brightness, etc.).
- › **【Driving Restriction】** : after it is expanded, you can choose to turn off or set the speed restriction. When you watch video while driving, if the vehicle speed exceeds the set value, a driving warning will pop up.

i NOTICE

Some national or local laws prohibit watching videos during driving. If there is no such setting, no video watching during driving should be default.

- › **【Status Bar Display】** : after it is expanded, it can be used to set the content displayed in the top status bar.
- › **【Standby Clock】** : it can be used to set the interface to display the dial clock or digital clock during standby.

Device list

In the system setting interface, touch the **【Device List】** button to switch to the device list interface to view and manage the connected devices.

Time and date setting

In the system setting interface, touch the **【Time and Date】** button to switch to the time and date interface.



2B1935889B89

- › **【Manual Time】** : you can manually set the time displayed by this system.
- › **【Manual Date】** : you can manually set the date displayed by the system.
- › **【Time Format】** : you can set the time in 12-hour system or 24-hour system.
- › **【Date Format】** : you can set the display format of date.
- › **【Manual Time Zone】** : you can manually set the time zone.

Language setting

In the system setting interface, touch the **【Language】** button to switch to the language setting screen and select the language displayed on the interface.

Steering wheel key

In the system setting interface, touch the **【Steering Wheel Key】** to switch to the steering wheel key interface to set the function of the custom button * on the steering wheel.

Storage space

In the system setting interface, touch the **【Storage Space】** button to switch to the storage space interface. It can be used to show the percentage of storage space used and clean the trash.

Factory setting

In the system setting interface, touch the **【Factory】** button to switch to the factory interface. It can be used to restore the factory setting.

System information

In the system setting interface, touch the **【System Information】** button to switch to the system information screen.

Interface introduction

You can view and change the name of the host, view the software version number, and update the system via USB.

i NOTICE

Go to your service provider to update the system, and also note the following:

- › To ensure safety during the upgrading process, place the vehicle in a safe environment.
- › To ensure the smooth progress of the upgrade, keep the power supply in ON mode, set the shift lever at P gear position, apply the parking brake, keep the vehicle in stationary status and shut down high-power electrical appliances (such as A/C, lights, speakers and so on).
- › During the upgrade process, all functions of the vehicle will be invalid, including following situations: the vehicle cannot be started; the A/C cannot be used; the door cannot be opened and closed; the audio-visual entertainment function becomes invalid; all the fault lights on the instrument will light up; the active and passive safety functions become invalid. However, after the upgrade is completed, all functions will be restored.
- › Do not change the vehicle state during installation (do not forcibly turn on the ignition switch and do not forcibly turn off the system).
- › It is normal if the screen becomes black or restarts during the process of upgrading the host or screen. You can wait for a few minutes and the host will finish restarting, and then the installation result will pop up. Don't change the vehicle state during this period.
- › When the upgrade is completed, ensure that this upgrade has been successful before closing doors and locking the vehicle. If the upgrade is failed or there are abnormal conditions during upgrade progress, contact the service provider.
- › After the upgrade is successful, the various updated system items, functions, interfaces, operating methods, etc. may change, which are not as described in the manual. The updated information will be included in the interface reminder during the upgrading progress.

4

Safety

Seat belts	210
Airbags	214
Child restraint system.....	221
Vehicle anti-theft system.....	226
Fuel shutoff system.....	228
Event data recorder	229

Seat belts

Vehicle equipment

Please note that this manual contains all the standard equipment, country-specific equipment and special equipment for this model series. Thus, some equipment or features described in this manual may not be installed onto your vehicle or are only available in some markets. For further configuration information, please refer to relevant sales information or consult with your distributor selling the vehicle to you.

Safety tips

4

Safety

- › The shoulder belt must not hang on the neck area, or pass under the armpit area.
- › The lap belt must be secured as firmly as possible around the lower part of the hip bone.
- › Each seat belt can only be used by one person. More than one person (including children) must not share the same seat belt.

If more than two people wear the same seat belt, when the vehicle is involved in a collision, not only the seat belt can not disperse the impact, but there is a danger of two people colliding with each other.

- › The seat belt shall not be twisted or slack.
- › Do not wrap the seat belt around objects with sharp corners, or it may be damaged during an accident.

- › Never use a seat belt that has undergone strong impact from an accident or which is otherwise damaged.
- › Do not remove, disassemble or alter seat belts.
- › Do not use the seat belt with foreign object in the buckle.
- › We suggest that when you use the seat belt, you shall keep your seat belt clean. Oil and water-based materials such as soil, oil stain, water, beverage, food residue, shall not be attached to the seat belt so as to ensure that it can be pulled out and retracted smoothly.
- › Do not use organic substances, such as benzene or gasoline, to clean the seat belts, and do not bleach or dye them.
- › Children must not play with the seat belt.

If a child accidentally wraps the seat belt around his or her neck while playing with the seat belt, he/she may not be able to pull the seat belt, resulting in serious injury or even death. In this case, if the locking tab of seat belt cannot be released, use a pair of scissors to cut the seat belt.

- › Inside seat belt design is mainly based on adult size, so please install proper child restraint system for children.

When the seat belt is being used correctly, if the belt is in contact with the child's neck or jaw area or slack to the hip, please switch to a child seat instead.

If the child is old enough to use inside seat belt, he (she) shall wear the belt properly.

› Precautions for pregnant women

We strongly suggest that you use the seat belt. You can also get effective advice by consulting with your doctor. The recommended way of wearing the seat belt for pregnant women is fundamentally the same as for other passengers. However, such passengers should take note of the following:

- 1) The lap belt should be positioned as low as possible in the abdomen area, below the bulge of the belly.
- 2) The shoulder belt should run over the passenger's shoulder, over the chest area but avoid the passenger's abdomen area.

If the seat belt is worn incorrectly, during emergency braking or collisions, the seat belt may tighten over the abdomen area, causing injury or even death to the pregnant mother and unborn child.

- › We strongly recommend that passengers who are ill or disabled use the seat belt. You can also get effective advice by consulting with your doctor.

- › When the seat belt is not in use, it shall be fully retracted. Do not twist or jam the seat belt, and do not allow the seat belt to touch any sharp objects. The seat belt buckle cannot be blocked by foreign objects. Otherwise, correct engagement of the seat belt locking tab and the buckle will be affected.

Wear the seat belt properly

- › Adjust seat backrest until it is vertical or near-vertical and provides adequate back support.
- › The seat belt shall be neat.
- › The shoulder belt should lie flat on the centre of the shoulder and not on the neck or elsewhere away from the shoulder.
- › The lap belt should be, as much as possible, fastened around the lower part of the hip bone.

WARNING

- › During the drive, all passengers must fasten their seat belts in the correct fashion. Failure to do so can lead to severe injury or even death from collisions or emergency braking as passengers' bodies are not sufficiently bound to seats.

Seat belts

› At all times, even if the driving distance is short, all passengers including the driver in the vehicle should wear their seat belts properly. Otherwise if an accident occurs, the risk of injury or death can be increased.

› The collision comes from the side or rear of the vehicle.

⚠ WARNING

› When using the pretensioner seat belt, wear it correctly and adjust the seat to the optimal seating position. Failure to do so will reduce the seat belt performance, leading to severe injury or even death.

› If you want to install, remove or dismantle the pretensioner seat belt, be sure to contact the authorised service centre. If the pretensioner seat belt is not used correctly, it will not work properly and may cause severe injury or even death in an accident.

› The pretensioner seat belt cannot be used repeatedly.

After the pretensioner has been deployed during the first collision, you should not extend or retract the seat belt again. At this point, be sure to contact the authorised service centre for replacement.

› When the pretensioner seat belt is working, white smoke will come out with a loud sound, but it will not cause a fire and is harmless to the human body.

› When a pretensioner seat belt is scrapped, be sure to contact the authorised service centre. Accidental movements of the pretensioner seat belt can cause personal injury.

Pretensioner seat belt

Both sides of the front and back rows of the vehicle are equipped with pretensioner seat belts.

When a collision occurs, the pretensioner can instantly tighten the seat belt, so that the passengers are best restrained and protected.

The force limiter maintains seat belt load at an acceptable level and reduce force exerted on the passenger's chest.

Operating conditions

The pretensioner seat belt works when the vehicle receives a significant impact from the front.

It may not work when the following mild collisions occur:

- › Head-on collision with a cement concrete wall and the like at a speed below 25 km/h;
- › Head-on collision with a small area object such as a fixed telegraph pole or a tree at a speed below 35 km/h;

The pretensioner seat belt may not fully function when the vehicle is subjected to the following severe collision.

- › The vehicle flips over by 90° or 180°.

Seat belts

How to use the three-point seat belt

1. Hold the locking tab and pull the seat belt out of the retractor. Make sure that you do not twist the seat belt in the process. If you are unable to pull the seat belt out of the retractor, you will need to first pull hard at the seat belt and then release it. Doing so will trigger the retractor and allow you to pull out the seat belt smoothly.
2. Insert the lock tongue into the buckle until you hear a "click" sound.



53A6BA9F6480

3. Pull up the shoulder belt until the lap belt sits securely on the body. Thus, the pelvis is better secured and the risk of injury during moments of impact is reduced.
4. Check that the shoulder belt is sitting across the chest and on the center of the shoulder. Thus, any impact will be distributed across the upper skeleton.

Airbags

Vehicle equipment

Please note that this manual contains all the standard equipment, country-specific equipment and special equipment for this model series. Thus, some equipment or features described in this manual may not be installed onto your vehicle or are only available in some markets. For further configuration information, please refer to relevant sales information or consult with your distributor selling the vehicle to you.

Tips for safety

4

Safety

- › Airbags cannot be reused.

Once an airbag has been used, it will not work anymore in the second or subsequent collisions, so be sure to contact authorised service centre for replacement.

- › The airbags are auxiliary devices to protect the passenger safety and should be used with the seat belts. In order to obtain the effect of airbags, the passengers must wear the seat belts correctly and maintain the correct posture.
- › Proper use of airbags can realize their safety effectiveness to the full. If it is used improperly, it may not play a security role, but may bring harm to passengers.

- › When the airbags are being deployed you will notice some loud sounds and smoke. This is normal and will not lead to a fire. The smoke released, however, may cause breathing difficulty when inhaled by individuals suffering from asthma or other respiratory disease. At this moment, it is safer to flee out of the vehicle immediately. If you are unable to evacuate from the vehicle, open vehicle doors or windows to let fresh air in.
- › When any debris (or gas) released by airbags deployment comes in contact with the eyes or skin, clean such material off using water as soon as possible. Otherwise, individuals with skin hypersensitivity may experience a skin reaction.
- › Do not touch airbag components after the airbag has been deployed. Because its component parts will become very hot, it may cause burns and other major injuries.
- › Please do not use the airbag for any other purposes.
- › Please get in touch with authorised service centre if you need to install radio equipment. Electromagnetic waves emitted by wireless equipment have a significant impact on the airbag control units.
- › It is forbidden to strike or squeeze the airbags and the position around it.

Avoid the condition that the airbags cannot work normally during accident or the airbags are accidentally deployed in normal driving, which will cause serious injuries to passengers or even death.

Airbag

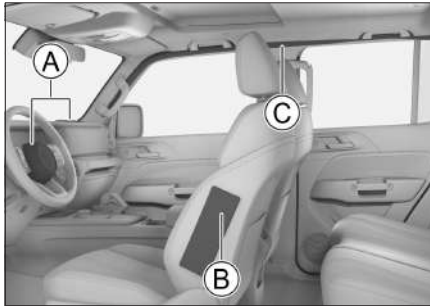

533FC588C72D

- Ⓐ Front airbags include the following types:
 - Driver airbag
 - Front passenger airbag
- Ⓑ Side airbag
- Ⓒ Curtain airbag

Front airbags

Overview

The front airbags are located in the steering wheel and the instrument panel in front of the front passenger seat. You can see the airbag signs on the steering wheel and instrument panel. When the vehicle encounters a strong front impact, the seat belt will be tightened. At the same time, the airbags at the driver side and front passenger side will deploy in order to distribute and cushion any force directed towards the head and chest.

Operating principle

When a head-on collision occurs resulting in moderate or severe impact, the sudden deceleration of the vehicle will be detected by a sensor. At this time, the control device will immediately deploy the airbag.

Precautions

- › The airbag may deploy when the bottom of the vehicle encounters the following kinds of severe impact:
 - 1) The vehicle hits the kerb.
 - 2) The vehicle falls into, or runs over a deep pit or drain.
 - 3) The vehicle climbs over the steps and hits or falls on the road.

Airbags

- › The airbag may deploy when the vehicle rolls over 90° and 180°. However, it will not be able to function to its full capabilities.
- › The airbag may not deploy when the vehicle encounters the following kinds of severe impact:
 - 1) Head-on collision with a cement concrete wall and the like at a speed below 25 km/h;
 - 2) Head-on collision with a small area object such as a fixed telegraph pole or a tree at a speed below 35 km/h;
- › If the object suffering impact changes in its shape or moves, the impact force from the collision will be reduced. In this case, the airbag may not deploy. When the vehicle collides into a truck from the back, if the vehicle runs under the cargo box, as the impact force recognized by the sensor is weak, the airbag may not deploy.
- › The airbag may also not deploy depending on the angle and direction of collision, even when vehicle speed is relatively high.
- › Do not allow your body to get too close to the steering wheel or to the lower part of the instrument panel:
 - 1) When driving a vehicle normally, the driver shall stay away from the steering wheel as far as possible while maintaining the correct driving position.
 - 2) The front seats shall be as far from the instrument panel as possible.
 - 3) All passengers shall fasten seat belts for optimal protection.
- › Do not sit on the edge of the seat or lean on the instrument panel while the vehicle is running. This is because the front airbag deploys at a high speed and with great force. If the passenger is too close to the airbag at this point, he or she may suffer severe injury or even death.
- › Do not allow children to stand in front of the airbag. When the front airbag deploys, it may cause severe injury or even death to child passengers. All children shall sit on the rear seats and be protected with the correct restraints.
- › Adhere to the following rules; otherwise these items may cause severe injury to passengers during airbag deployment:
 - 1) Do not place objects on the instrument panel or lean umbrellas and the like against it.
 - 2) Do not leave objects in the storage box exposed.
 - 3) Do not hang any objects on vehicle windows or on the interior rear-view mirror.
 - 4) Do not install any decorations on the steering wheel horn.

5) Do not place luggage, pets or other objects between the airbag and the driver or front passenger.

- › Do not clean the inside of the vehicle with water or cleaning solution.

The inflator in airbag is a deployment device. If it becomes damp, the normal operation of the airbag will be affected which may cause serious injuries or death.

- › Do not apply wax, stickers or similar items to the airbag cover.

Failure to adhere to the advice can impede airbag deployment.

- › Do not damage the airbag cover.

Otherwise, it will not work normally. Therefore, be sure not to open or damage the airbag cover.

- › Do not dismantle, modify or install devices such as airbags, instrument panel and steering wheel.

Improper operations can cause the airbag to malfunction or deploy by mistake, thereby causing severe injuries or even death.

- › Do not modify the suspension.

If the vehicle height or suspension stiffness is changed, the airbag may deploy by mistake, thereby causing severe injuries or even death.

- › Consult with the authorised service centre for assistance when you need to install a guard plate and air deflector at the front of the vehicle.

Modifications to the front of the vehicle can cause distortion to impact signals sent to the airbag sensor, thereby triggering accidental deployment of the airbag, which may cause serious injury or even death.

- › Be sure to consult with the authorised service centre for assistance when you need to repair the front of the vehicle or the cab.

Improper repairs can cause distortion to impact signals sent to the airbag sensor, thereby leading to airbag malfunctions, which may cause serious injury or even death.

Warning label



7C49E3CEA3ED

The label is located on the central pillar. It serves to remind you that the vehicle is equipped with front airbags and you should be aware of the relevant matters.

⚠ WARNING

- › Do not place luggage, pets or other objects between the airbag and the driver or front passenger.

Airbags

- › Do not bend your legs and put your feet on the seat cushion.

Side airbag

Overview

The side airbag is located inside the seat backrest outer liner, and the airbag identification is attached to the seat backrest. The side airbag is the supplement of the seat belt. In case of a side collision, the side airbag will reduce the damage to passengers and prevent subsequent collisions.

Operating principle

When the vehicle encounters impact from the side, the sensor will detect an acute change in vehicle speed and then send a signal to the control device. If the airbag work condition is met, the side airbag will deploy instantaneously.

When a side collision occurs, only the side airbag on the side suffering an impact will deploy. If the impact occurs on the front passenger side of the vehicle, even if there is no one in that seat, the side airbag on front passenger side will deploy all the same.

Precautions

- › The side airbag may not deploy sometimes when the vehicle encounters a mild impact described below:
 - 1) Front collision;

- 2) A minor side impact with weak signal received by the electronic control unit;
- 3) Rear collision;
- 4) Rollover.

- › Do not place any object over the side airbag. Otherwise, the normal work of the side airbag will be disturbed.
- › Never attach any object around the side airbag deployment area. Failure to adhere to this can cause such objects to dislodge when the side airbags deploy.
- › Do not remove, repair or modify the seat with a side airbag and parts around the side airbag deployment area.
- › Do not lean against the side airbag deployment area.

Curtain airbag

Introduction

The curtain airbag is located on the lower edge of roof; you can find the airbag mark on the pillar. The curtain airbag is a supplement to seat belt. In case of a side collision, the curtain airbag will reduce the injury to passengers' heads and prevent future collisions.

Operating principle

When the vehicle encounters impact from the side, the sensor will detect an acute change in vehicle speed and then send a signal to the control device. If the curtain airbag work conditions are met, the curtain airbag on the collision side will deploy instantaneously.

Precautions

- › The curtain airbag may not deploy when the vehicle encounters mild impact such as what is described below:
 - 1) Front collision;
 - 2) Electronic control unit receives a weak signal of mild side impact;
 - 3) Rear collision;
- › Do not remain close to the vehicle doors, pillars or roof rail, or kneel on the front passenger seat. Failure to adhere to the advice can cause passengers' heads to suffer a severe impact when the curtain airbag deploys, which may cause serious injuries or even death. Be sure to pay attention to this warning especially when children are in the vehicle.
- › Never attach any object around the curtain airbag deployment area. Failure to adhere to this can cause such objects to dislodge when the curtain airbag deploys.
- › Do not hang heavy or sharp objects on the coat hook.

Do not use clothes hangers if you wish to hang your clothing, and opt for the coat hook directly instead. Failure to adhere to this can cause clothes hangers to dislodge when the curtain airbag deploys.

- › Do not remove, repair or modify parts around the curtain airbag deployment area.

Do not modify roof, roof handrail, roof handrail bracket and side dome light.

Rolling Sensor Curtain Airbag (RSCA)

In the event of a rollover accident, the sensor will detect a sharp change to the angular velocity in the vehicle longitudinal axis direction and send the signal to the control device. If the working conditions of the curtain airbags are met, the curtain airbags on both sides will instantly deploy.

i NOTICE

Depending on the model configuration, some models may not be equipped with RSCA. Refer to the actual vehicle for details.

Airbags

Far-end airbag

Introduction

Far-end airbag is located in the outer gasket of the driver's seat backrest (the side away from the vehicle door), and there is an airbag sign on the seat backrest. In the event of a side collision, the deployment of far-end airbag can reduce the risk of injury caused by collision between the driver and the front passenger or by the driver hitting the front passenger side door or pillar, so as to protect heads, chests, and other important parts of passengers.

- › Do not use any items to cover the far-end airbag. Otherwise, the normal function of the far-end airbag may be disturbed.
- › Never attach any items around the far-end airbag deployment area. Otherwise, there may be a danger of these items being projectile through the interior when the far-end airbag is deployed.
- › Do not remove, repair or modify seats with far-end airbags and parts around the far-end airbag deployment area without permission.

4

Safety

Operating principle

In the event of a side collision, the sensor will detect an acute change in vehicle side acceleration and then send a signal to the control module. If the airbag work condition is met, the far-end airbag will be deployed instantaneously.

Precautions

- › The far-end side airbag may not deploy when the vehicle encounters mild impact such as what is described below:
 - 1) Front collision
 - 2) Mild side collision with weak signals
 - 3) Rear collision
 - 4) Rollover

Child restraint system

Vehicle equipment

Please note that this manual contains all the standard equipment, country-specific equipment and special equipment for this model series. Thus, some equipment or features described in this manual may not be installed onto your vehicle or are only available in some markets. For further configuration information, please refer to relevant sales information or consult with your distributor selling the vehicle to you.

Safety instructions for child seat

Warning label

Type I



90A96F30A2E6

Type II



5648C823E2C8

This label is on the sun visor of front passenger side to indicate that the vehicle is equipped with a front airbag and you should be aware of the relevant matters.

⚠ WARNING

Do not use rear-facing child restraint systems on the seats protected by front airbag (activated). Otherwise, child death or serious injury may occur.

- › Please do not install a child seat on the front passenger seat.

Because this places the child passenger too close to the airbag. In the event of airbag deployment, it can cause severe injury or even death to the child passenger.

- › If the child seat is not installed with child seat fixing device, use the seat belt to install it and follow the installation instructions provided with the child seat.
- › Properly fasten the child seat inside the vehicle.

If you install the child seat incorrectly, in the event of emergency braking or accident, severe injury or even death may occur.

- › Do not place unsecured child seat protection devices in the vehicle.

Child restraint system

If you leave it inside the vehicle, it may come into contact with passengers or other objects in the event of emergency braking or severe impact, causing a severe injury or even death.

- › Even when the child has sat in a child seat, take care that his or her head or body is not leaning against the vehicle door pillar or roof rail.

When the curtain airbag fully deploys, it can be very dangerous as the deployment force may cause severe injury or even death to the child.

- › Depending on the different types of child seat, when installing or removing a child seat, refer to the installation instructions and precautions provided with the child seat.
- › Be sure to leave enough space around the child seat and adjust the seat in front if necessary.

Fixing points for child seat

Lower fixing points for child seat



1DE4B67D3799

There are 4 fixing points on the lower part of the child seat in the clearance between the rear seat backrest and the seat cushion. Remove the fixing point trim cover first before use.

Top tether strap fixing point for child seat



CCE1A83DCF76

There are 3 fixing points for the child seat top tether strap on the rear side of rear seat backrest.

i NOTICE

Due to different models, some models have only two child seat top tether strap fixing points on the left and right sides of the seat backrest. For details, please refer to the actual vehicle.

⚠ WARNING

Fixing points for child seat are designed to withstand only those loads imposed by correctly fitted child seat. Under no circumstances shall they be used for adult seat belts, harnesses, or for attaching other items or equipment to the vehicle.

Child restraint system

Recommended child seat categories

ISOFIX is a mounting system for car child seats based on international standards. In the user's country, child seats need to meet the ECE R44 specification. Only child seats that meet the above specification are allowed to be used in vehicles.

Weight group

Group	Weight (kg)	Age
Group 0	Maximum 10	0 to 9 months old
Group 0+	Maximum 13	0 to 2 years old
Group I	9 to 18	9 months to 4 years old
Group II	15 to 25	4 to 7 years old
Group III	22 to 36	6 to 12 years old

Rear-facing child seat, quality group 0/0+.

Forward-facing child seat, quality group I.

Cushioned child seat, quality group II / III.

Installation of child seat

When installing a child seat, you must use a child seat that is appropriate for the child's age, weight and size to restrain an infant or a child in the seat.

Applicability information of child seat for different seat positions

Group	Seat position		
	Front passenger seat	Rear seat	
		Outside	Middle
Group 0	X	U	X
Group 0+	X	U	X
Group I	X	U	X
Group II	X	U	X
Group III	X	U	X

Note: the letters filled in the above table are defined as follows:

U - this seat is suitable for universal child restraint system certified under this weight group.

X - this seat is not suitable for use with child restraint systems in this weight group.

Applicability information of ISO-FIX child seat

Group	Size	Fixing module	ISOFIX position
			Rear-row outside
Portable bed	F	ISO/L1	X
	G	ISO/L2	X
Group 0	E	ISO/R1	IL

Child restraint system

Group	Size	Fixing module	ISOFIX position
			Rear-row outside
Group 0+	E	ISO/R1	IL
	D	ISO/R2	IL
	C	ISO/R3	IL
Group I	D	ISO/R2	IL
	C	ISO/R3	IL
	B	ISO/F2	IUF
	B1	ISO/F2X	IUF
	A	ISO/F3	IUF

Note: the letters filled in the above table are defined as follows:

IUF - this seat is suitable for general forward-facing ISOFIX child restraint system approved for the weight group;

IL - this seat is suitable for special ISOFIX child restraint system on the list; Such restraint systems may be special, restricted or semi-general.

X - ISOFIX position is not suitable for use with this weight group and/or ISOFIX child restraint system of this size.

Child seat installed with the seat belt

1. Move the front passenger seat as far forward as possible so that there is no contact between the front passenger seat and the child in the rear.

2. If the backrest angle of the seat where the child seat is installed is adjustable, adjust it to an appropriate position to ensure that the backrest can stably support the child seat.
3. If the headrest of the seat where the child seat is installed can be adjusted or removed, adjust it to an appropriate position or remove it. Otherwise, the child seat may interfere with the headrest and can not be able to fit against the backrest.
4. Pull out the shoulder belt, move the belt along the indicated route on the child seat and insert the locking tab into the buckle until you hear a "click" sound.
5. With your body weight pressing down on the child seat, allow the shoulder belt to retract and tighten. There must be no signs of slack to the shoulder belt.
6. Shake the child seat gently to make sure that it has been properly secured.

CAUTION

If a raised seat cushion is used, do not remove the headrest. Also, the top of the headrest shall be adjusted to a position that is flush with or closest to the top of the child's head.

Child restraint system

Child seats installed with the child seat fixing device

ISOFIX or LATCH is a standard protection system specially designed for child seats. Child seats can be installed with ISOFIX or LATCH in both seats on the lateral sides of the rear row.

1. Move the front passenger seat as far forward as possible so that there is no contact between the front passenger seat and the child in the rear.
2. If the backrest angle of the seat where the child seat is installed is adjustable, adjust it to an appropriate position to ensure that the backrest can stably support the child seat.
3. If the headrest of the seat where the child seat is installed can be adjusted or removed, adjust it to an appropriate position or remove it. Otherwise, the child seat may interfere with the headrest and can not be able to fit against the backrest.
4. Slide the child seat lock mechanism into the lower fixing point, and ensure that the two ISOFIX lock mechanisms are securely fixed.
5. When fixing the top tether strap, refer to the instruction manual of the child seat.
6. Shake the child seat gently to make sure that it has been properly secured.

CAUTION

If a raised seat cushion is used, do not remove the headrest. Also, the top of the headrest shall be adjusted to a position that is flush with or closest to the top of the child's head.

WARNING

- › If the child seat is equipped with a top tether strap, tighten the top tether strap according to the installation instructions and precautions provided with the child seat.

Otherwise, severe injury or even death may be caused in the event of emergency braking or collision.

- › Do not lower the headrest after fastening the child seat top tether strap to its fixing point.

Otherwise, it may come into contact with the top tether strap and loosen the strap as a result. In the event of emergency braking or collision, this can cause the child seat to turn, bringing severe injuries or even death.

Vehicle anti-theft system

Vehicle equipment

Please note that this manual contains all the standard equipment, country-specific equipment and special equipment for this model series. Thus, some equipment or features described in this manual may not be installed onto your vehicle or are only available in some markets. For further configuration information, please refer to relevant sales information or consult with your distributor selling the vehicle to you.

System introduction

The vehicle anti-theft system helps to keep your vehicle and valuables from being stolen. The vehicle anti-theft system will emit audible and visual alarm if someone tries to enter the vehicle by force.

WARNING

Do not attempt to modify the vehicle anti-theft system.

Instructions

System activation

1. After the door is successfully locked by the button on the key, PEPS or the mechanical key, the emergency flasher flashes once, and the vehicle enters the pre-arm state.

In the pre-arm state, you can still operate the vehicle without triggering the anti-theft alarm.

2. After the pre-arm state lasts for about 15 seconds, the vehicle will automatically enter the armed state and the vehicle anti-theft function will be activated.

CAUTION

Please check whether all the vehicle doors, tailgate and engine hood are completely closed. Otherwise, the vehicle anti-theft system cannot be activated.

NOTICE

The central control button will fail in the armed state of the anti-theft state of the vehicle.

Alarm trigger condition

In the armed state, the following actions can trigger an alarm:

- › The engine hood is open.
- › Use the mechanical key to open the vehicle doors.
- › A door or the tailgate is forcibly opened.

Alarm cancellation

After triggering the anti-theft alarm of the vehicle, the alarm can be reset by the following operations:

- › Set the power supply to the ON mode.
- › Start the vehicle successfully.

Vehicle anti-theft system

- › When the power supply is in OFF mode, unlock the doors or the tailgate via the button on the key or the PEPS.

System off

The vehicle doors and the tailgate are unlocked via the key button or the PEPS. The emergency flasher flashes twice and the vehicle anti-theft function is off.

Fuel shutoff system

Vehicle equipment

Please note that this manual contains all the standard equipment, country-specific equipment and special equipment for this model series. Thus, some equipment or features described in this manual may not be installed onto your vehicle or are only available in some markets. For further configuration information, please refer to relevant sales information or consult with your distributor selling the vehicle to you.

Fuel shutoff system

The system will shut off fuel supply and minimize the risk of fuel leakage when the airbag deploys due to the vehicle collision.

After activation of this system, if you want to restart the engine, please refer to the following methods:

1. Switch the power mode to OFF mode.
2. Restart the vehicle.

WARNING

Before starting the vehicle, you must check the ground below the vehicle. If you discover any fuel leakage, it means that the fuel system is damaged. Please do not restart the vehicle at this point.

4

Safety

Vehicle equipment

Please note that this manual contains all the standard equipment, country-specific equipment and special equipment for this model series. Thus, some equipment or features described in this manual may not be installed onto your vehicle or are only available in some markets. For further configuration information, please refer to relevant sales information or consult with your distributor selling the vehicle to you.

System introduction

The vehicle is equipped with the event data recorder (EDR).

The event data recorder (EDR) is mainly used to record data related to vehicle dynamic system and safety system when a vehicle collision happens in order to help understand the operation conditions of vehicle system. However, since collision severity and type vary, EDR may not record the data.

i NOTICE

EDR records data only when a vehicle meets a major collision. When the vehicle runs normally, EDR does not record data.

Data reading

Except the vehicle manufacturer, other parties (such as law enforcement agencies) can read the data recorded in EDR after connecting the laptop with the on-board diagnostic interface to enter the EDR by using CANoe equipment.

The data reading equipment can be purchased from CANoe software vendors.

The data items recorded by EDR and their uses are as follows:

Data item	Applications
Braking state	Record the brake pedal status during collision
Speed during collision	Record the speed at the time of collision
Status of the seat belt lock body	Record the safety belt status during collision
Status of the airbag system warning lamp	Record whether the airbag failure warning lamp is on before collision

Data disclosure

Any data recorded by EDR will not be disclosed to third parties except in the following circumstances:

- › With the consent of the vehicle owner or lessee.

Event data recorder

- › To be used in a lawsuit at the official request of the police, court, or government department.

However, if necessary, the data recorded by the EDR will be used to:

- › Research and develop the vehicle safety performance.
- › For R&D purpose, data is disclosed to the third parties without disclosing specific information about the owners and their vehicles.

5

Emergency

On-board tools.....	232
Vehicle lifting.....	233
Spare tyre	234
Replacing the spare tyre.....	237
In case of a vehicle accident	241
Jump start	242
Engine overheating	244
Towing.....	246

On-board tools

Vehicle equipment

Please note that this manual contains all the standard equipment, country-specific equipment and special equipment for this model series. Thus, some equipment or features described in this manual may not be installed onto your vehicle or are only available in some markets. For further configuration information, please refer to relevant sales information or consult with your distributor selling the vehicle to you.

Storage location for on-board tool kit

The reflective vest, on board file package, first-aid packet, tyre barometer will be located in the storage case in the instrument panel in front of the front passenger seat.

The fire extinguisher is located on the floor of front passenger (at the position of passenger feet space).

The jack, warning triangle and on-board tool kit are under the luggage area cover, you can notice it when opening the cover.

i NOTICE

Some models may not be equipped with first-aid packet, tyre barometer and fire extinguisher depending on different model configuration. Please refer to the actual vehicle for details.

⚠ CAUTION

- › The driver himself must be familiar with the placement and usage of the on-board tool in order to cope with emergency.
- › It is recommended that you return the on-board tool kit to their designated positions after use and fix them securely. If they are placed randomly in the vehicle, they may cause injury.
- › The jack equipped with the vehicle is designed for use with the vehicle only. Do not apply this jack to other vehicles, and do not apply jacks designed for other vehicles to your vehicle.
- › The fire extinguisher and the medicine in the first aid kit have an expiry date and need to be checked regularly. They should be replaced in time if necessary.

Vehicle equipment

Please note that this manual contains all the standard equipment, country-specific equipment and special equipment for this model series. Thus, some equipment or features described in this manual may not be installed onto your vehicle or are only available in some markets. For further configuration information, please refer to relevant sales information or consult with your distributor selling the vehicle to you.

Vehicle lifting position

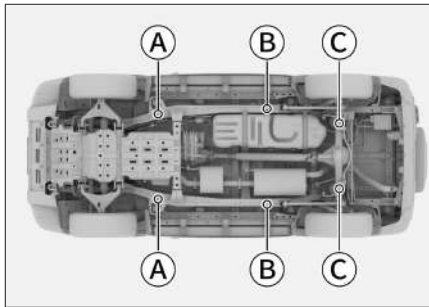

2ED14D9EDA30

- Ⓐ Lifter/Jack lifting position
- Ⓑ Lifter lifting position
- Ⓒ Jack lifting position

The vehicle lifting position is shown in the above figure.

⚠ WARNING

- › Do not operate a vehicle that is not properly supported, as this may cause serious damage, personal injury, or death.

- › If the vehicle needs to be lifted, the lifting tool must be placed against the lifting point. Lifting at any other point may cause damage to the vehicle or cause accidents.
- › When using a lifting tool to lift the vehicle, do not place any part of your body under the vehicle to avoid injury.

⚠ CAUTION

When placing the jack, be careful not to bump into the pipeline. Otherwise, the pipeline leakage may be caused to damage the vehicle.

Spare tyre

Vehicle equipment

Please note that this manual contains all the standard equipment, country-specific equipment and special equipment for this model series. Thus, some equipment or features described in this manual may not be installed onto your vehicle or are only available in some markets. For further configuration information, please refer to relevant sales information or consult with your distributor selling the vehicle to you.

Spare tyre introduction

The spare tyre hangs on the tailgate and its position is shown in the figure.

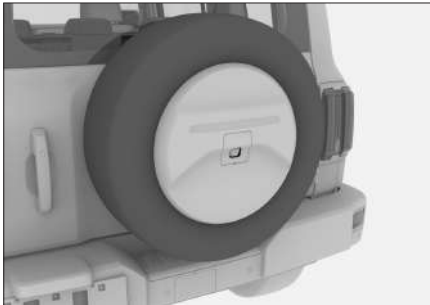

6D3A4B24127B

⚠ CAUTION

- › Due to low frequency of use and less friction with the ground, friction coefficients of four tyres will be slightly different after the spare tyre is put on, so drive carefully. It is recommended that you repair the standard tyre as soon as possible and replace the spare tyre.

- › Regularly check the status of the spare tyre such as tyre pressure, cracks and bulges, etc., to ensure that the spare tyre is available for use in case of a failure.

Removing and restoring

1. Close the tailgate and use a flathead screwdriver to open the cover plate on the spare-tyre cover.

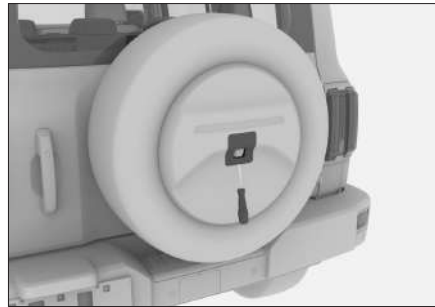

DDF512EEE26D

2. Install the rear-mounted spare tyre cover nut wrench into the wheel nut wrench.

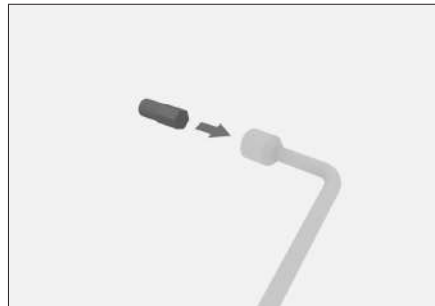

40C5EF183A2F

Spare tyre

- Using the assembled wheel nut wrench, unscrew the bolt under the cover plate counterclockwise and remove it, and then remove the spare tyre cover.

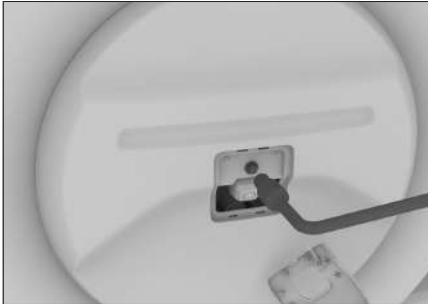

C8C1CC82CE3C

- Insert the mechanical key into spare tyre lock cylinder, and then the spare tyre lock cylinder can be pulled out. For how to get the mechanical key, see the Removing the Mechanical Key.(▷ Page 21)

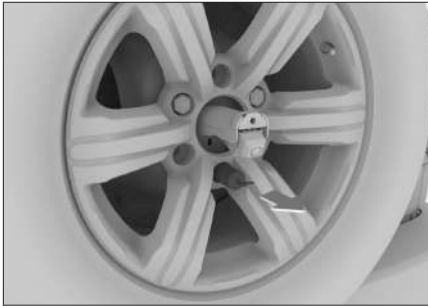

1AD993835419

- Install the removal socket into the wheel nut wrench.

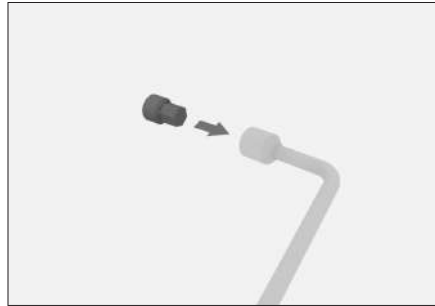

8F6444E093F3

- Using the assembled wheel nut wrench, loosen the nut at the spare tyre lock cylinder counterclockwise and remove it.

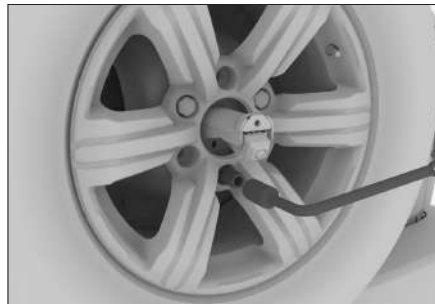

0390F3D183C7

5

Emergency

Spare tyre

7. If the vehicle is equipped with a wheel nut trim cover, you must first remove it with the wheel nut trim cover removal tool provided with the vehicle.



967CB04320FF

8. Use a wheel nut wrench to loosen and remove the spare tyre retaining nut counterclockwise, and then remove the spare tyre.

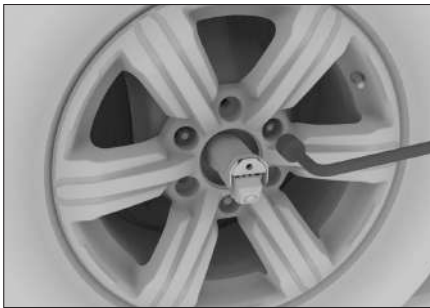

55BB886E21BC

When placing the spare tyre on the ground, make sure the rim of the spare tyre faces up to avoid scratches.

9. Put the spare tyre back in the reverse order of removal.

i NOTICE

When putting the spare tyre back, hold the lock cylinder by hand to remove the key after the spare tyre lock cylinder is installed, otherwise the key will get stuck when being removed and re-inserted.

5

Emergency

Replacing the spare tyre

Vehicle equipment

Please note that this manual contains all the standard equipment, country-specific equipment and special equipment for this model series. Thus, some equipment or features described in this manual may not be installed onto your vehicle or are only available in some markets. For further configuration information, please refer to relevant sales information or consult with your distributor selling the vehicle to you.

Tyre failure symptom

When any of the following situations occur, check if the tyres are punctured or have gone flat:

- › The steering wheel shakes.
- › The vehicle vibrates abnormally.
- › The vehicle is leaning at an abnormal angle.

⚠ CAUTION

- › If a tyre is flat or punctured during driving, hold the steering wheel firmly and gently step on the brake pedal to slow down. Emergency braking or sudden steering is prohibited. Otherwise, it may lead the vehicle to go out of control.

- › If there is a flat tyre, replace with the spare tyre immediately. Continuing driving with a flat tyre for any reason can cause instability in your drive and lead to an accident. In addition, doing so can cause damage to rims, wheels, the suspension and the vehicle body.

Preparation for spare tyre replacement

1. All passengers must exit the vehicle.
2. Park the vehicle at a hard, flat place where it will not impede the normal flow of traffic and where you will be able to work safely.
3. Apply the parking brake.
4. Shut down the vehicle.
shift to P gear and shut down the vehicle.

⚠ WARNING

Do not lift the vehicle with the jack when the gear is in N. Otherwise, the jack will not be able to stably support the vehicle, resulting in an accident.

5. Turn on the emergency flashers and place the warning triangle.
6. Prepare the spare tyre, the jack, the jack adjustment lever, the wheel nut wrench and the wheel chock.

⚠ CAUTION

- › You need to use the wheel chock together with the jack.

Replacing the spare tyre

- › The wheel chock can be purchased at authorised service centre. Please contact the authorised service centre for the relevant details.
- › If you do not have a wheel chock handy, you can use a piece of rock large enough to stabilize the tyre instead.

Method to replace the spare tyre

Removal of the defective tyre

1. Secure the tyre.

Be sure to use suitable tyre chock against the tyre, and place the tyre chocks on both sides of the tyre in the diagonal direction of the tyre to be replaced.

2. Remove the wheel nut trim cover.



E61DCF90D85A

For vehicles equipped with wheel nut trim covers, use the wheel nut trim cover removal tool supplied with the vehicle to remove the wheel nut trim covers in turn.

3. Loosen the nuts.



70B3D0335EE9

Loosen the nut slightly counterclockwise (approx. 1 turn) in the order shown using the wheel nut wrench.

- ##### 4. Place the jack under the lifting position and adjust the jack position and height to ensure that the jack is stably held in the lifting position. For lifting position, see "Vehicle lifting".
- (▷ Page 233)

⚠ CAUTION

You must observe the followings when using the jack. Otherwise, the vehicle may be damaged or the jack may shift, resulting in serious injury:

- › The engine must be shut down.
- › Do not use the jack when there are passengers inside the vehicle.
- › The jack must be placed on a flat, hard ground.
- › Do not place any objects on the top or bottom of the jack.
- › The jack should be lifted to a height at which the tyre can be changed.

Replacing the spare tyre

- › After lifting the vehicle by the jack, do not enter under the vehicle.
- › When lowering the vehicle, pay attention to the surroundings to avoid injury to the operator and other individuals.

5. Raise the vehicle.

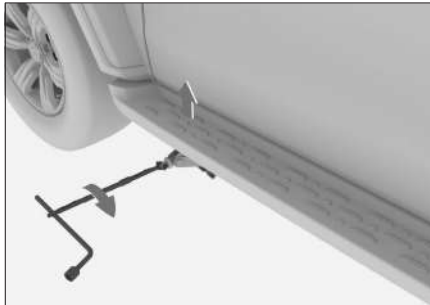

Combine the jack, the jack adjusting rod and the wheel nut wrench into the form shown in the figure above, and turn the jack clockwise to make the tyre slightly off the ground.

⚠ CAUTION

- › When using the jack, you should ensure that the jack adjustment lever should be coaxial with the rotation centre of the jack screw.
- › During operation, you should first lift the vehicle up slightly. Carefully check whether everything is normal, and then continue raising the vehicle.

6. Remove all fixing nuts and remove the tyre.

⚠ CAUTION

- › When placing the tyre on the ground, keep the spokes facing upwards to avoid damage.
- › Before installing the spare tyre, it is best to place the removed tyre at the bottom of the vehicle to avoid the displacement of the jack, causing an accident.

Install the spare tyre

1. Remove any dirt from the wheel mounting surface.

Before installing the spare tyre, remove the foreign object from the wheel mounting surface, otherwise the wheel nut may loosen during the driving process, thus causing the wheel to leave the vehicle.

2. Install the spare tyre and tighten the nuts with approximately the same force, making sure that the nut is in full contact with the wheel mounting surface.
3. Lower the vehicle by turning the jack counterclockwise.

Replacing the spare tyre

4. Tighten the wheel nuts 2 to 3 times in the order indicated in the figure.

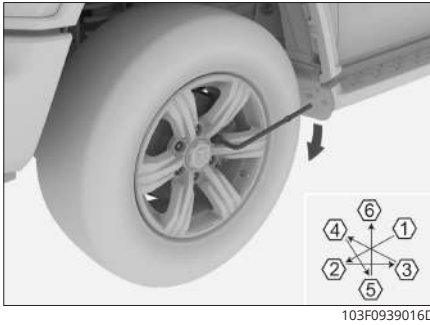

Tightening torque: $120 \pm 10 \text{ N}\cdot\text{m}$

i NOTICE

After replacing the spare tyre, tighten the nut to the tightening torque as soon as possible using a torque wrench. Otherwise the wheel nut is easy to be loose or fall off, which may lead to serious casualties.

5. For vehicles equipped with wheel nut trim covers, install wheel nut trim covers.
6. Install the faulty tyre, put all tools back to the designated position and fix them properly.

⚠ WARNING

Burning tyres by individuals produces toxic gases. Please send it to authorised service centre for treatment.

⚠ CAUTION

- › Do not use damaged, cracked or deformed nuts and wheels.

- › Tighten the nuts when using the wheel nut wrench, or the nuts are likely to be disengaged while screwed, resulting in personal injury.
- › Do not step on the wheel nut wrench or use other tools to over-tighten the nuts. Doing so may damage the wheel nuts.
- › When installing nuts, do not apply any lubricant or grease. If the nuts are too screwed, the nuts and the wheels are likely to be damaged; if the nuts are loosened, the wheels are likely to be disengaged during driving, resulting in an accident.

5

Emergency

In case of a vehicle accident

Vehicle equipment

Please note that this manual contains all the standard equipment, country-specific equipment and special equipment for this model series. Thus, some equipment or features described in this manual may not be installed onto your vehicle or are only available in some markets. For further configuration information, please refer to relevant sales information or consult with your distributor selling the vehicle to you.

Traffic accidents occur to the vehicle

When the vehicle is forced to stop on road because of traffic accidents or vehicle failure, in order to warn other vehicles, please take the following measures:

- › Turn on the emergency flasher.
- › Wear a reflective vest attached to your vehicle.
- › Please place the warning triangle behind your vehicle in accordance with local traffic laws and regulations.

Jump start

Vehicle equipment

Please note that this manual contains all the standard equipment, country-specific equipment and special equipment for this model series. Thus, some equipment or features described in this manual may not be installed onto your vehicle or are only available in some markets. For further configuration information, please refer to relevant sales information or consult with your distributor selling the vehicle to you.

Symptoms of a drained vehicle battery

- › Clicking sounds are emanating from the starter, which is not turning over. Even when the starter turns over, it outputs very little power, and you are unable to start the engine.
- › The headlamps are shining more dimly than usual.
- › The horn does not sound or the sound is weak.

Jump start method

If you cannot start the vehicle due to discharged battery, you can connect the battery of another vehicle by jumper cables to start the vehicle.

The wire cross-section of the jumper cables should be no less than 25 mm².

⚠ CAUTION

- › Not all vehicle batteries can be used. The jump start can only be performed with a battery having a rated voltage of 12 V.
- › Do not try to start the engine by pushing or towing the vehicle.

1. Connect the booster cables in the following order.

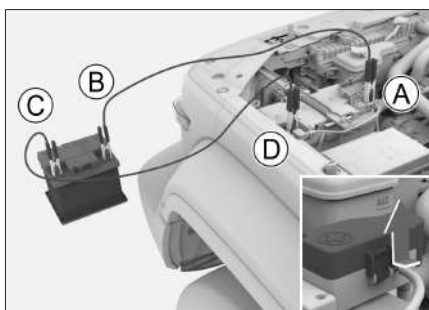

- Ⓐ Positive terminal on discharged battery ⊕
For connecting, open the protective cover on the positive terminal of the battery first.

Ⓑ Positive terminal on charging battery ⊕

Ⓒ Negative terminal on charging battery ⊖

Ⓓ Negative terminal on discharged battery ⊖
2. Recharge the battery.

Start the rescue vehicle, increase the engine speed slightly, and keep such speed for about 5 minutes to temporarily charge the discharged battery.

Jump start

3. Start the vehicle with discharged battery.

If the vehicle still cannot be started, check whether the jumper cables have been connected correctly, and then charge the battery again.

4. Remove the jumper cables.

Once the vehicle is started, remove the jumper cables in an order contrary to the connection.

WARNING

- › During charging or jump start, gas may escape from the battery. There is a risk of explosion. Be sure to keep the battery away from sparks, open flames and other flammable materials.
- › Battery fluid is corrosive, and it can cause serious injuries to eyes and skin. In case of accidental contact, rinse immediately with plenty of water and seek medical attention immediately.
- › When connecting or removing jumper cables, do not wind the cables with fans, belts and the like.
- › Ensure that all cables are connected correctly, and keep a certain distance between their ends to avoid contact between positive and negative terminals.

CAUTION

If a battery is discharged frequently, go to the authorised service centre for inspection.

Engine overheating

Vehicle equipment

Please note that this manual contains all the standard equipment, country-specific equipment and special equipment for this model series. Thus, some equipment or features described in this manual may not be installed onto your vehicle or are only available in some markets. For the further configuration information, please refer to relevant sales information or consult with your distributor selling the vehicle to you.

Engine overheating

Preventing from overheating

The off-road cooling mode can be turned on or off through **【Vehicle Setting】** → **【Driving Setting】** → **【Off-road Cooling Mode】** on the multimedia display screen . The engine is prone to overheating when running under high load for a long period of time. Turning on the off-road cooling mode allows the engine cooling to be switched on earlier to prevent or mitigate engine overheating.

Overheating symptoms

i NOTICE

Under extreme conditions (such as dragging, towing, climbing, overloading, etc.), the engine may overheat and the power of the whole vehicle will decrease.

- › The water temperature indicator is in the red zone.
- › Engine accelerates weakly.
- › There is steam emanating from the hood.
- › A/C compressor may stop working automatically.

Handling methods

1. Park the vehicle in a safe place and shut down the engine.
If the A/C system has been turned on at this point, turn it off.
2. Check if steam is emanating from the hood.
 - › If no steam is emanated, open the engine hood and then start the engine.
 - › If steam is emanating, wait until there is no more steam. Open the hood, and then run the engine.
3. Check if the cooling fan is running.

Engine overheating

- › If the fan is not working, shut down the engine and contact a authorised service centre.
 - › If the fan is running normally, wait for the water temperature to begin to drop, and then turn off the engine.
4. Check the coolant level.
Add the coolant if the coolant level is too low. And check for pipeline leakage; if there is any leakage, contact a authorised service centre.
5. Check whether there is any foreign object in the core of the radiator.
If there is any foreign object, remove it.

WARNING

- › Do not open the engine hood immediately if you see steam emanating from the engine hood. Doing so may cause serious injury such as burns.
- › When the radiator is at a higher temperature, do not open the radiator cap or the overflow tank lid. Otherwise, steam or coolant escaping may cause severe injuries such as burns.
- › When opening the radiator cap or the overflow tank lid, do not touch or get close to the fan and belt. Also, open the cap slowly after covering it with a piece of cloth.
- › When the engine is running, do not touch or get close to the fan and belt. Otherwise, there is a risk of your hands or clothing becoming caught within and of severe injury as a result.
- › Do not add coolant when the engine is overheated. If a coolant is suddenly added, it is easy to damage the engine. Add a coolant after the engine is completely cooled.

CAUTION

If the water temperature indicator comes to the red warning range again during driving, head to your nearest authorised service centre for inspection as soon as possible.

Towing

Vehicle equipment

Please note that this manual contains all the standard equipment, country-specific equipment and special equipment for this model series. Thus, some equipment or features described in this manual may not be installed onto your vehicle or are only available in some markets. For further configuration information, please refer to relevant sales information or consult with your distributor selling the vehicle to you.

Towing with a professional vehicle

⚠ WARNING

Traction must comply with local regulations regarding trailer towing.

When the vehicle needs to be towed, we suggest an elevating truck or flat truck, and you shall entrust a authorised service centre or a specialized towing company with the traction.

Towing with the flatbed truck

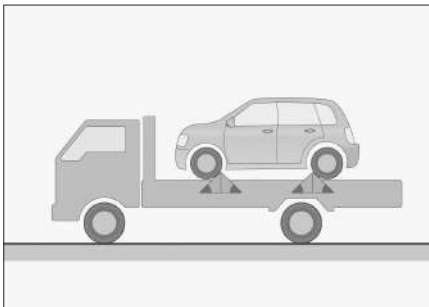

04FD77FA04F8

When using a flatbed truck, you must lock the vehicle firmly.

Towing with the lift truck

Towing from the front

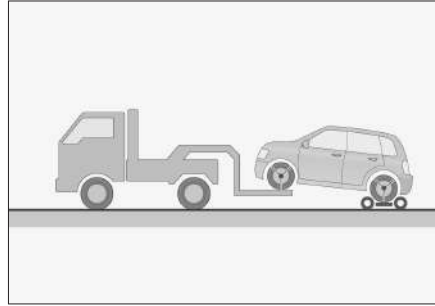

0AF8FFF4F031

Place the tow truck under the rear wheel and lock firmly.

Towing from the rear

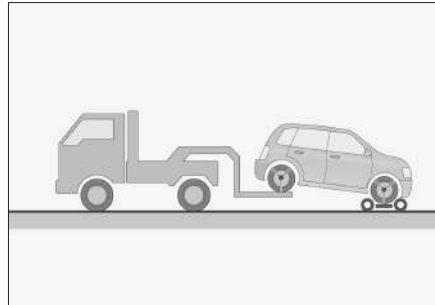

FFEE0CD03B9B

Place the tow truck under the front wheel and lock firmly.

Towing with the hoisting type truck is prohibited

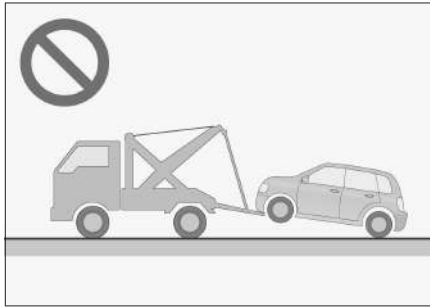

It is forbidden to use a hoisting type truck for towing, otherwise it may damage the vehicle body.

⚠ CAUTION

For a 4WD or RWD vehicle, please use a flat truck or a towing trolley during their traction. Traction with two wheels on the ground is forbidden; otherwise, the vehicle will be seriously damaged.

Towing with the tow hook

Tow hook

Front tow hook

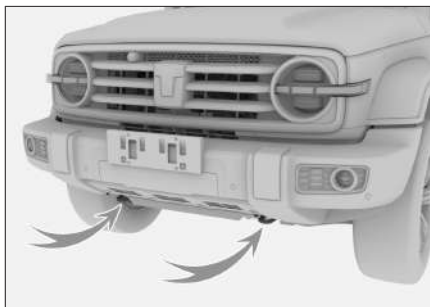

The front tow hook is located in both sides of the front chassis.

Rear tow hook

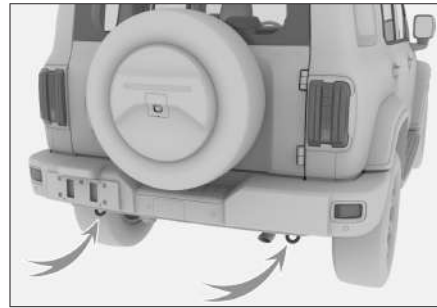

The rear tow hook is located in the both sides of the rear chassis.

i NOTICE

Depending on vehicle configuration, some vehicle models may equipped with one front tow hook and one rear tow hook. Please refer to actual vehicle for detail information.

Tow rope

The tow rope should be elastic to protect vehicles. It is recommended to use an artificial fibre rope or the rope made of similar elastic materials.

The tow rope can only be installed on the designated tow hook or towing ring of the vehicle.

When installing the tow rope, you should be careful not to damage the vehicle body. The distance between the towing vehicle and the towed vehicle should be within 4 to 10 m.

Towing

A recovery blanket should be attached to the centre of the tow rope. For towing at night, a tow rope with reflective materials should be used as much as possible to increase the warning effect.

⚠ CAUTION

- › You need to purchase the tow rope by yourself.
- › Do not use a steel rope to tow as that will damage the bumper.

Vehicle fault

When the vehicle fails, if you cannot use a professional vehicle to tow your vehicle, you can use a trailer hook to tow the vehicle temporarily. This towing method can only be used to tow a vehicle on hard pavement in a short distance at low speed.

⚠ WARNING

When towing, you must comply with local regulations regarding trailer towing.

Towing the vehicle

For towing the vehicle, the driver must sit in the vehicle and operate the steering wheel and brake pedal, with the wheels, axles, steering system, brake system, transmission system (transmission, etc.) and lighting system (turn signal light and brake light) in good condition.

The detailed methods are as follows:

1. Start the vehicle and shift to the gear N.

If the vehicle cannot be started, set the power supply to the ON mode. For automatic transmission vehicles, the shift lever emergency unlocking device can be used to switch to the gear N.(▷ Page 111)

For 4WD vehicles, the drive mode needs to be set to 2WD mode.

⚠ CAUTION

- › When you cannot switch the transmission to the gear N, do not use tow hooks for towing.
- › Do not use the towing hooks to tow vehicles in 4WD mode.

2. Turn on the emergency flasher, release the parking brake and wait for towing.

Towing speed cannot exceed 30 km/h and total towing distance during transmission life cannot exceed 50 km.

⚠ CAUTION

- › If the vehicle is not started, the assist system will not work, and the steering and braking operations will be difficult. The vehicle speed shall be reduced as much as possible during towing.
- › During towing, pay attention to the brake lights of the vehicle in front to avoid looseness of the tow rope.

- › When the vehicle moves on a long downhill road, ropes shall not be used to tow the vehicle.
- › Do not tow the vehicle backwards.

Towing other faulty vehicles

1. When towing, turn on the emergency flasher and follow relevant local laws and regulations.
2. Start slowly until the tow rope tightens, then accelerate carefully.

CAUTION

- › Do not tow a vehicle heavier than the towing vehicle; otherwise, the vehicle can be easily damaged.
- › Avoid sudden start or unstable driving operation; otherwise, the trailer hook or tow rope will be subjected to excessive tension.
- › When the vehicle moves on a long downhill road, ropes shall not be used to tow the vehicle.
- › Do not tow the vehicle backwards.

When the vehicle gets stuck or bottoms out

When driving in snow, mud and sand, the vehicle is easy to get stuck or bottom out. Therefore, you should drive carefully.

If the vehicle gets stuck, you can try the following operations:

1. Shut down the vehicle and apply the parking brake.

2. Remove the mud, snow or sand around the stuck tyres.
3. Place wood blocks, stones or other materials to help improve the tyre adhesion.
4. Restart the vehicle.
5. Release the parking brake. Be careful to accelerate and get the vehicle out of the pit.

NOTICE

While freeing the vehicle, pay attention to the following:

- › Make sure that the surrounding area is clear and free from any other vehicles, objects, or persons.
- › When the vehicle gets out from the pit, it will suddenly rush forwards or backwards. Please be careful.
- › When getting out of mud or snow, pay attention to whether there are larger objects such as stones in the mud or snow. Please clean them up timely to prevent damage to the vehicle body and sensors during getting out.

Towing

When the vehicle gets stuck or bottoms out, please contact professional rescue teams or call the customer service hotline if the vehicle cannot get out of the trap in the methods above. Dragging unprofessionally for rescue is prohibited.

WARNING

Please observe the following precautions during rescue to avoid potential vehicle damage and ensure personal safety.

1. When using a tow hook for towing, securely fasten a recovery blanket in the middle of the tow rope. This precaution prevents the tow hook or rope from breaking and rebounding, thus averting potential vehicle damage and ensuring personal safety.
2. Never drag the vehicle from the side or vertically, with the best angle of tow hook within the range of 5° up and down and 25° left and right.
3. Never drag the vehicle during launch start. The initial towing speed should not exceed 5 km/h (start off slowly until the tow rope is taut).
4. When the vehicle is to be dragged with a trailer hook, the drag traction shall not exceed 30 kN.

6

Maintenance

Necessity of vehicle maintenance	252
Engine compartment	253
Safety labels and signs.....	259
Part replacement.....	261
Vehicle maintenance.....	267

Necessity of vehicle maintenance

Vehicle maintenance, a health diagnosis of the vehicle, can reduce the trouble of repairing the vehicle.

When the vehicle is in use, its components and parts will inevitably wear out. To ensure safe driving conditions, regular inspections, maintenance, and repairs are required to maintain and restore vehicle performance.

Vehicle maintenance making you drive more safely

During the maintenance, you can carry out necessary preventive maintenance according to the use of the components and parts, so that you can safely drive the vehicle before the next maintenance.

Extending the service life of the vehicle and reducing the use cost of the vehicle

Components and parts such as brake linings and tyres, etc. cannot be used permanently, as they will gradually wear out while in use. Use of components and parts that exceed the wear limit is likely to cause vehicle breakdown and even lead to traffic accidents. Therefore, it is necessary to conduct regular maintenance.

Engine compartment

Vehicle equipment

Please note that this manual contains all the standard equipment, country-specific equipment and special equipment for this model series. Thus, some equipment or features described in this manual may not be installed onto your vehicle or are only available in some markets. For the further configuration information, please refer to relevant sales information or consult with your distributor selling the vehicle to you.

Safety tips

WARNING

- › The engine compartment is a hazardous area for operation and must be handled with extreme caution!
- › When performing oils inspection and filling operations, observe the following requirements, otherwise burns or fire may occur:

The vehicle is shut down.

The parking brake is applied.

Allow the engine to cool down completely.

Keep children away from the engine compartment.

Do not splash oils on the engine.

Do not allow water to come into contact with the engine compartment.

- › When performing operations related to fuel system or electrical devices, observe the following precautions, otherwise fire may occur:

Disconnect the negative terminal of the battery.

Do not smoke.

Do not operate near open flames.

CAUTION

When adding oils, note that the oils must never be misused. Otherwise, serious functional defects and damage to the vehicle parts may be caused.

Engine compartment

Fluid level

Vehicle equipped with E20CB engine

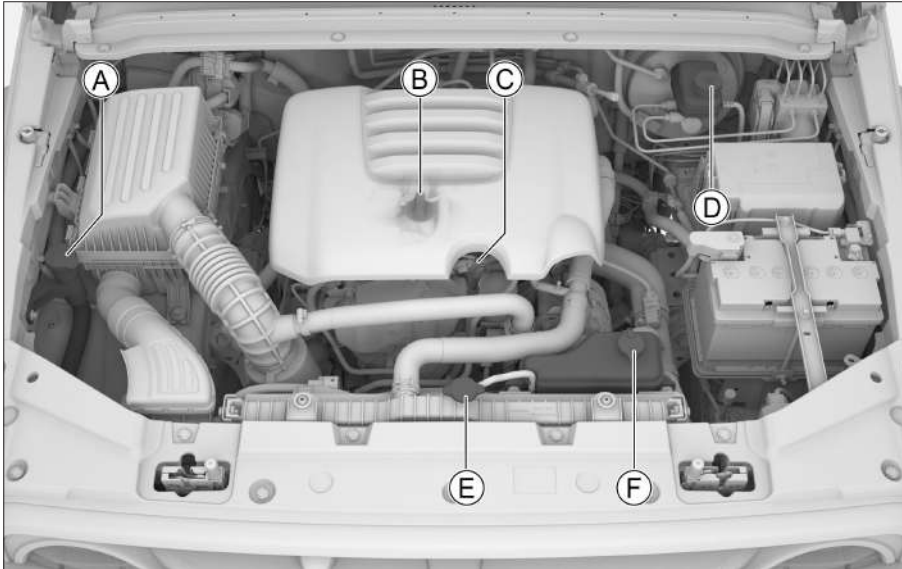

AE9F060E8360

- Ⓐ Windscreen washer fluid reservoir
- Ⓑ Engine oil filler cap
- Ⓒ Engine oil dipstick
- Ⓓ Brake fluid tank
- Ⓔ Radiator cap
- Ⓕ Overflow tank

6

Maintenance

Engine compartment

Engine oil

Check

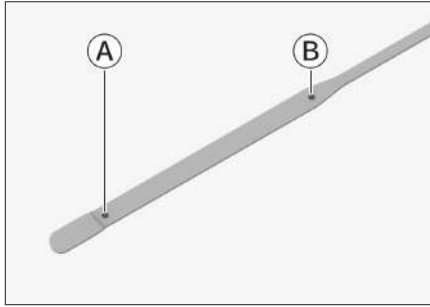

8F3D41CDBC64

- Ⓐ Lower limit
- Ⓑ Upper limit

Stop the vehicle on flat ground. Warm up the engine to normal water temperatures, and then switch the power supply to OFF mode. Wait for 10 minutes before conducting the engine oil level check.

The oil level should be between the maximum and minimum levels marked on the oil dipstick.

If the engine oil level is close to or lower than the minimum level marked, add engine oil until it is at the level between the maximum and minimum levels marked.

i NOTICE

- › The shape of the oil dipstick varies depending on the engine.
- › Check that the engine oil level is not less than 1/3 of the dipstick scale (between the upper limit and the lower limit) before the vehicle climbs an extreme slope; otherwise, add engine oil.

! WARNING

- › When the engine is running, if you contact or get close to the rotating parts such as the belt or the fan, your hands, clothing, tools and so on may be trapped into the rotating parts, resulting in accidents.
- › Take care to prevent burns when checking or adding engine oil.
- › Keep the engine oil in a safe place when it is not in use. Engine oil that leaks into the ground or enters into bodies of water causes environmental pollution.

Filling

Open the engine oil filler cap, and slowly pour the oil so as to avoid oil spill. Any oil overflow must be removed immediately. Otherwise, the spilled oil may cause damage to the compartment components.

Engine oil plays an important role in ensuring engine performance and lifespan. Therefore, it is important to use high-quality and purified oil. Please use only engine oil that meets specifications so as to ensure the vehicle performance.

Oil additives

Your vehicle does not require any oil additives, as additives cannot improve the performance and durability of the engine.

Engine compartment

⚠ CAUTION

- › Therefore, check and replace engine oil on a regular basis. Otherwise, insufficient oil levels or deteriorated engine oil may cause poor lubrication of engine rotation parts, thereby cause sintering and hence damage to the engine.
- › The engine oil works for lubrication and cooling. The engine oil level goes down over time even if you are driving normally, as a certain amount of engine oil for lubricating the piston and the valve will also be mixed in the combustion chamber and burned. Engine oil levels may go down depending on the specific driving conditions.
- › Do not add excessive engine oil.

Fill

Allow the engine to cool down, and then slowly open the lid.

If the coolant spills, clean it up immediately to prevent parts or paint from being damaged.

Please use only coolant that meets the specifications.

i NOTICE

- › The coolant contains ethylene glycol to lower its freezing point. Indiscriminate disposal may lead to water pollution.
- › Please contact authorised service centre, if you need to replace the coolant.

⚠ WARNING

- › Do not open the radiator cap when the engine is hot. There may still be some pressure inside the cooling system. Opening it at this point may cause burns or other injuries when heated coolant spurts out.
- › The coolant contains harmful substances. Do not contact the coolant with any part of the body. Flush with plenty of clean water in time in case of contact.
- › Seek medical advice immediately if the coolant is swallowed accidentally.

Engine coolant

Check

The water level in the overflow tank should be checked regularly.

Check that the fluid level in the overflow tank is between the minimum and maximum marked levels.

If the coolant level is lower than the minimum level marked, top up with new coolant until the coolant level is between the maximum and minimum levels marked. Also make sure that the cooling system shows no signs of leakage.

Engine compartment

Brake fluid

Check

The fluid level in the tank should be checked regularly.

Check whether the fluid level in the tank is between the minimum and maximum marked levels.

If the brake fluid level is lower than the minimum level marked, add new brake fluid until the fluid level is between the maximum and minimum levels marked. Also make sure that the braking system shows no signs of leakage.

Filling

Open the tank cover. Pour in the fluid slowly to prevent overflow. Any fluid overflow must be removed immediately. Otherwise, the spilled fluid may cause damage to the compartment components.

Only use brake fluid that meets specifications.

CAUTION

Before opening the tank cover, be sure to clean the cover and its surrounding area; otherwise, dust, sand and other foreign objects may be mixed into the brake fluid, resulting in decrease of braking performance or damage to brake components.

WARNING

- › Insufficient brake fluid levels can compromise brake performance and increase the risk of an accident.
- › Brake fluid is harmful to the human body and corrosive. In case of accidental contact, rinse it immediately with plenty of water. If you ingest it, go to a hospital immediately.

Windscreen washer fluid

Filling

Open the tank cover. Pour in washer fluid slowly to prevent overflow. Any washer fluid overflow must be removed immediately.

You should use quality washer fluid for better cleaning capabilities and for anti-freeze protection in cold season.

NOTICE

You should use the detergent with enough anti-freeze performance, if the ambient temperature is lower than 0 °C.

The detergent should be placed out of the reach of children to avoid accidental ingestion.

The detergent is flammable and should be stored far from fire.

Engine compartment

CAUTION

Please do not top up liquids such as soapy water into the tank in place of the detergent. Otherwise, the paint on vehicle body may be damaged.

WARNING

Do not top up washing fluid when the engine is at a high temperature, or when the engine is running. This is because the washing fluid contains alcohol. Spilling the fluid on the engine carries a risk of fire.

Radiator and fan

Regularly check the radiator, fan and other heat-radiating components in the engine compartment. If a component is particularly dirty or has foreign objects, please clean it in time. When you cannot determine whether it is working normally, please send your vehicle to a authorised service centre for checking.

Please timely check whether the radiator, fan and other heat-radiating components are covered with dirt when the vehicle is driving in a bad environment (such as driving through water, sand and mud) each time. If they are covered by dirt, please go to a authorised service centre for inspection and cleaning timely.

Battery

The vehicle is equipped with a maintenance-free battery.

When the battery shows low level, it is necessary to charge or replace the battery in time. Please head to authorised service centre for service if you need to replace the battery.

Safety labels and signs

Engine compartment warning label

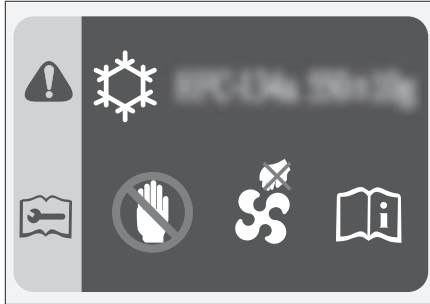

6FC9C3B803CD

This label is located on the engine compartment front cover plate or the front grille trim plate to prompt you:

- › The type and filling amount of air conditioning refrigerant.
- › The cooling fan may be started at any time. Do not put your hand into the fan shield. Otherwise, when the fan is started unexpectedly, serious personal injury may be caused.

Radiator cover warning label

Type I



F4DF3F6E951D

Type II



361F87CC1BAF

The label is on the radiator cap, which serves to remind you to refrain from opening the radiator cap when the engine is overheated. Otherwise, this may cause scald or the risk of coolant spillage.

Battery warning label

Type I



340CF5EC9B21

Safety labels and signs

Type II



A86516835B47

Type III



378F054B09F7

This label is located on the battery to inform you of the following precautions before installing, removing, or inspecting the battery:

- › Children should be kept away from the battery.
- › The battery may produce flammable gases in the use or charging process, so it should be away from high-temperature heat source and open flame. Otherwise a fire or explosion is likely to occur.
- › The battery contains corrosive liquid.
- › Take necessary protective measures such as wearing goggles during operation.

Part replacement

Vehicle equipment

Please note that this manual contains all the standard equipment, country-specific equipment and special equipment for this model series. Thus, some equipment or features described in this manual may not be installed onto your vehicle or are only available in some markets. For further configuration information, please refer to relevant sales information or consult with your distributor selling the vehicle to you.

Fuses

If any electrical components do not work, the fuse may have been blown out. In this case, carry out the inspections based on the following operations and replace the fuses if necessary:

1. Turn off all electrical components.
2. Switch the power supply to the OFF mode, apply the parking brake, and disconnect the negative terminal of the battery.
3. The fuses are located in the following positions:

> Located in the fuse box of the engine

compartment

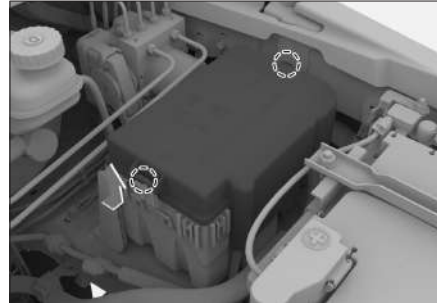

78F038BD6DF4

Press and hold the two pawls on the fuse box cover, and then pull up the fuse box cover to open the fuse box.

> Located in the instrument panel near the steering wheel



7213BDF343C9

Remove the storage case (fuse box cover) shown in the figure and you can see the fuse.

For the removal and installation of the storage case, see "Removal and installation of the instrument panel storage case".(> Page 263)

Part replacement

> Under the luggage area cover plate

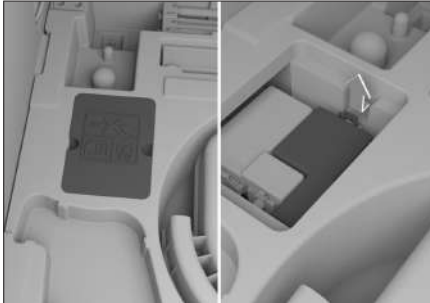

E7288137AD2D

Open the luggage area cover, remove the fuse box service port cover. As shown in the figure, press and hold the pawls at the fuse box cover, and then pull up the fuse box cover at the same time to open the fuse box.

⚠ CAUTION

- > Never let water or other liquids get into the fuse box. Otherwise, the electrical components will be damaged.
- > Install the fuse box cover on the fuse box correctly. Otherwise, penetration of moisture or dirt will affect the use of fuses.

4. Use the fuse clips in the vehicle to pull out the fuses. Find the fuse of the faulty electrical appliance according to the fuse label and check it.



569B84B04E08

⚠ CAUTION

- > The fuse clip and the spare fuse are located in the cover of the engine compartment fuse box.
 - > Fuse labels are attached to the cover of the engine compartment fuse box and cover of the instrument panel fuse box. With these labels, the relationship between fuses and electrical components can be determined.
 - > Since there may be more than one fuse causing the fault, check all the fuses that may cause the fault before the fault disappears. If the failure cannot be eliminated in the end, contact the authorised service centre for handling.
5. Check the wire inside the fuse. If it is blown out, replace it with a spare fuse with the same amperage.

Part replacement

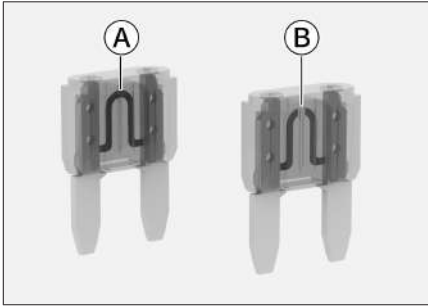

6DC672024A26

- Ⓐ Normal fuse
- Ⓑ Blown fuse

⚠ WARNING

For blowout fuses, do not try to repair or replace them with fuses with inconsistent colours or amperages; otherwise, a fire will occur due to cable overload.

6. Check whether the electrical components return to normal operation.

⚠ CAUTION

If a spare fuse with the same amperage is blown out again in a short time or the electrical components do not return to normal operation, it indicates that the vehicle may have a serious electrical system failure. At this juncture, contact the authorised service centre for assistance in a timely manner.

Disassembly and assembly of instrument panel storage box

To remove the instrument panel storage box when checking the instrument panel fuse, please refer to the following operations:

Removal

1. Open the storage box, and pull the storage box in the direction of the arrow shown in the figure to separate its left claw and stop bolt from the instrument panel.

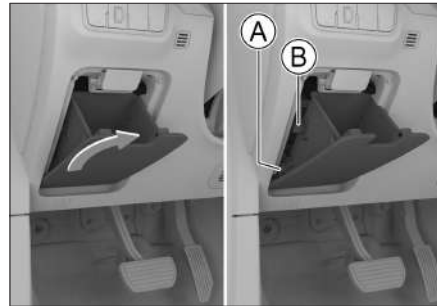

CD9F708FA9C3

- Ⓐ Left claw
- Ⓑ Limit bolt

Part replacement

2. Pull the storage box in the direction of the arrow shown in the figure to disengage the right claw and stop bolt from the instrument panel, and then remove the storage box.



B995C65D606B

Installation

Install and reset the claws on both sides of the storage box first, and then push the storage box to close, so as to install and reset the stop bolt.

Wiper blades

Front wiper blade replacement

You should regularly check the wiper blade. Replace the wiper blade immediately if you discover the following conditions:

- › Cracks or hardened areas are found on wiper blades.
- › When using a wiper, leave streaks or scratch.

⚠ CAUTION

When lifting and putting back the wiper, you shall not pull the wiper blade directly to avoid deformation or even damage.

1. Raise the wiper arm from the wind-screen.

⚠ CAUTION

Do not open the engine hood while the wiper is lifted. Doing so can cause damage to the engine hood and the wiper.

2. Rotate the wiper blade as indicated by the arrow in the figure to maximize the angle between it and the plastic connector.



B26AF2BA18B2

3. Remove the wiper blade from the wiper arm.

Part replacement

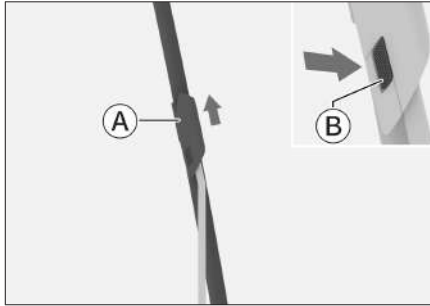

70E1DDF744AB

- Ⓐ Wiper blade
- Ⓑ Flexible cleat

Press down on the flexible cleat and pull the wiper blade in the direction indicated at the same time until it separates from the wiper arm.

⚠ CAUTION

When the wiper blade is not installed, never place the wiper arm directly on the windscreen as it is capable of scratching the windscreen.

4. Install a new wiper blade and put the wiper back to the windscreen.

To facilitate installation, please refer to step 2 to maximize the included angle between the wiper blade and the plastic connector.

After installation, please move the wiper up and down to ensure that it is installed in place.

Replace rear wiper blade

1. Raise the wiper arm from the windscreen.

⚠ CAUTION

The rear wiper arm has a limited lift angle of about 45°. Do not over lift or use excessive force when lifting up, otherwise there is a risk of damage.

2. Pull the wiper blade in the direction shown until the blade is free of the wiper arm.



3AC3CEB9D50F

⚠ CAUTION

When the wiper blade is not installed, never place the wiper arm directly on the windscreen as it is capable of scratching the windscreen.

3. Install a new wiper blade and put the wiper back to the windscreen.

Part replacement

Lamp maintenance

Lamp calibration

The front combination lamps on a new vehicle have been calibrated at the factory. If you often carry heavy items in the vehicle, the front combination lamps may need to be recalibrated. The calibration of the front combination lamps should be done at the authorised service centre.

Replacing bulbs

All exterior lamps are LED lamps and cannot be disassembled separately or replaced individually. In case of bulb damage or malfunction, it is recommended that you go to the authorised service centre for inspection and repair as soon as possible.

WARNING

- › Do not modify external lighting and signalling devices.
- › Do not add external lighting and signalling devices which are not specified in the compulsory standards.

About lamps fogged

Under conditions such as driving or washing vehicle on a rainy day, there may be fog inside the lamp cover. This is caused by the temperature difference between the inner and outer air of the lamps and it is the same phenomenon as the window glass fogging on rainy days. It doesn't mean any problem in function. However, when a significant amount of water or water vapour accumulates inside the lamp cover, please contact the authorised service centre for assistance.

CAUTION

Do not use chemical solvents or strong cleaning agents to scrub the exterior lamp cover to avoid damage to the exterior lamp cover.

Vehicle maintenance

Vehicle equipment

Please note that this manual contains all the standard equipment, country-specific equipment and special equipment for this model series. Thus, some equipment or features described in this manual may not be installed onto your vehicle or are only available in some markets. For further configuration information, please refer to relevant sales information or consult with your distributor selling the vehicle to you.

Tyre maintenance

To ensure safe driving, make sure that the tyres used suit your vehicle in their models and sizes with a good tread pattern and appropriate tyre pressure.

WARNING

- › Do not use tyres that are excessively worn, damaged, under-inflated or over-inflated; otherwise, accidents and personal injury may occur.
- › You must abide by all manual instructions regarding tyre inflation and maintenance.
- › Burning tyres by individuals produces toxic gases. Please handle it properly.

Off-road driving

Before off-road driving, you may lower the tyre pressure to adapt to off-road driving conditions. Therefore, after completing off-road driving, be sure to inflate the tyres to the standard tyre pressure. Insufficient inflation is the main cause of abnormal damage such as tyre cracking and blowouts.

After driving on off-road conditions, please check the wheels and tyres for any damage. Off-road driving may damage the wheels and tyres, leading to tyre failure, vehicle loss of control, or personal injury.

Tyre check

When checking tyre inflation state, you should also check whether there is external damage, foreign objects or excessive wear, etc.

If any of the following circumstances are found, replace the tyre as soon as possible:

- › There is damage and bulges on the tyre tread or sides.
- › There is excessive wear to the tyre tread.

Tyre pressure

Maintaining appropriate tyre pressure levels can maximize vehicle handling ability, tyre tread life and driving comfort.

Vehicle maintenance

Under-inflated tyres wear out unevenly and affect the handling of the vehicle, fuel consumption (for fuel vehicle) and energy consumption (for electric vehicle), causing air leakage due to overheating.

Over-inflated tyres can lead to an uncomfortable ride as well as damage to the tyre due to uneven road surfaces, as well as uneven wear to the tyres.

It is recommended that you check the tyre pressure regularly, including the spare tyre (if fitted).

Tyre pressure should be measured when the tyre is cold. The measurement conducted when the vehicle is parked for more than 3 hours or its driving distance is not more than 1.5 km will get more accurate data. If you check the tyre pressure when the tyre is hot (after driving for a few kilometres), the pressure reading will be 30 to 40 kPa higher than the cold-state reading. This is normal. Do not deflate the tyre to reach the prescribed cold-state pressure as this will lead to insufficient tyre pressure.

i NOTICE

Even if the tyres are in good condition, the tyre pressure may drop by 10 to 20 kPa every month. Please check them regularly.

Tyre wear

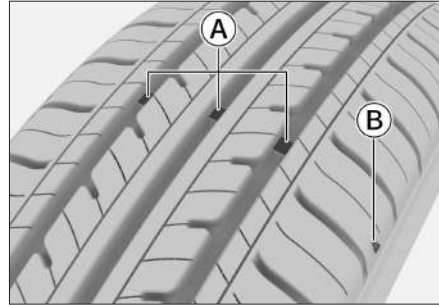

Ⓐ Tyre wear mark

Ⓑ Tyre wear mark position figure

i NOTICE

The tyre wear mark position figure is a schematic diagram, which is used for reference only. Please refer to the actual vehicle.

You must replace tyres as soon as possible once they have been worn to the maximum tolerable limit.

If you continue to use tyres with shallow treads or where the tyre wear mark has exposed, this will lead to situations such as longer braking distances, failure in steering and cracked tyres and possibly accidents.

If you find tyre wear uneven, or feel a certain continuous vibration when driving, go to the authorised service centre for inspection.

When installing new tyres, perform dynamic tyre balance to ensure ride comfort and to prolong tyre use life.

Vehicle maintenance

Tyre rotation

It is recommended that tyre rotation should be conducted for tyres of the rear and front wheels on a regular basis to extend the life of the tyre and make tyre wear even.

The tyre rotation should be done by the professionals and it is recommended to be done by the authorised service centre.

Wheel balance

Unbalanced wheels can affect vehicle control performance and tyre service life. Even under the normal use conditions, the wheels may lose their balance. Therefore, the wheels should be balanced according to the wheel dynamic balance parameters.

Avoid tyre flatness

If the vehicle is parked in a high temperature environment for an extended period of time, a slight deformation of the tyre in the contact position with the ground may occur, which is called "tyre flatness", which is normal. However, when the vehicle is running, the vehicle body and steering wheel may shake. As the mileage increases, the tyre will get hot and return to its original shape, and the shake will gradually disappear.

When the vehicle is stationary for an extended period of time, the tyre flatness can be minimized by any of the following methods:

- › The tyre pressure can be increased (by about 300 kPa), which cannot be used for normal driving. Before driving, the tyre pressure must be restored to the recommended tyre pressure.
- › Vehicles must be moved at least once every 30 days (15 days best) and the movement must make the original force bearing point rotate at least 90°.

Sunroof maintenance

Daily maintenance frequency

The daily maintenance frequency depends on the driving condition and the use frequency of the sunroof.

If you are driving through sandy areas or areas with high rainfall levels, it is recommended that you increase the frequency of routine maintenance.

CAUTION

If the sunroof is not maintained on schedule, it can lead to sunroof leaks or abnormal noise. Adjust maintenance frequency depending on the conditions of use. For instance, in sandy zones or in seasons when there is higher usage, you should increase the frequency of routine maintenance.

Vehicle maintenance

Routine maintenance procedure

Dust and impurities may be concentrated in the sunroof seal strip, mechanical parts or rails, which may result in an abnormal sound or malfunction of the sunroof and also clog the drainage system. Regularly open the sunroof, remove dust and impurities, and use clean cloth and water to wipe the sunroof seal strip surface, as well as regularly apply grease on the mechanical parts for maintenance.

Open up the sunroof and check that the sunroof does not show signs of being obstructed in the course of operation. If there seems to be obstruction, please head to a authorised service centre for services.

CAUTION

- › When the sunroof malfunctions, please head to a authorised service centre as soon as possible for check and maintenance.
- › In cold icing conditions, do not try to forcibly open the sunroof to prevent damage to the sunroof motor and sunroof seals. You must wait for the interior temperature to rise and for seal strips of sunroof and sunroof opening to defrost before you try to open the sunroof.

- › Open the sunroof after washing the vehicle in cold icing conditions. Use a piece of soft, dry cloth to wipe dry seal strips of sunroof before driving.
- › The sunroof must be closed fully before the vehicle enters a car wash facility. Do not allow water jets to be pointed directly at seal strips of sunroof. Keep off the water from vehicle due to the deformation of the seal strip under the pressure of the high pressure water column, as a result, it may damage the seal strip.
- › When driving on bumpy roads or in hilly areas, do not open the sunroof fully for extended periods of time as the vibrations may cause damage to internal sunroof components.
- › In the rainy season, step up checks for any sand or dust on seal strips of sunroof, and remove them in a timely manner to ensure good sealing performance of sunroof.

Exterior maintenance

Car wash

A regular car wash helps to protect its appearance. Please regularly clean your vehicle.

Vehicle maintenance

i NOTICE

The longer such corrosive substances as insects, bird droppings, tree resins, road dust, industrial fallout, tar, soot, and snow melt salt remain on the body surface, the greater the damage to the body paint. High temperatures (for example, sun exposure) will further aggravate the corrosion effect.

To prevent damage to the vehicle paint, immediately remove corrosive substances on the body surface. Do not wait until your vehicle is due for a complete wash.

Wash your vehicle in a shady spot and not under direct sunlight. If the vehicle has been parked under direct sunlight for a long time, you must move the vehicle to a shady spot before cleaning, and wait until the body surface is cooled down.

Cleaning methods

1. Check that there are no fallen leaves, bird droppings, etc., on the vehicle body.
Remove these dirt, and then rinse immediately with clean water so as not to damage the vehicle body surface finish.
2. Wash the vehicle thoroughly with water to remove surface dust.
Clean your vehicle using water and a soft brush, a sponge, or a piece of soft cloth.

3. After washing and cleaning the vehicle, use a special leather or soft towel to dry off the vehicle. Do not allow the vehicle to dry out naturally as this may cause the vehicle body to lose its luster or generate water stains.

! CAUTION

- › Do not use acid, strong alkaline, strong chemical cleaning agents to wash the vehicle. Prolonged soaking by strong detergents will cause serious corrosion of the body paint and bright stripes, affecting the appearance of the vehicle.
- › After washing the vehicle or driving through flooded road, depress the brake pedal lightly to make sure that the brake is functioning normally.
- › When washing the vehicle in cold season, do not flush the gaps in the keyholes or doors, etc. to prevent the lock hole or the seal strip from freezing.
- › When washing the vehicle, do not open the fuel door to rinse its interior.

Waxing

Waxing is conducive to vehicle maintenance, and the vehicle must be thoroughly cleaned before waxing to ensure the effect of waxing.

Vehicle maintenance

At present, there is a wide range of car wax in the market, and the car wax performance is different, so you must be careful when selecting the wax. Otherwise, the wax will result in paint discolouration instead of protecting the vehicle body.

Under normal circumstances, the role and characteristics of car wax, the degree of vehicle age, paint colour and driving environment and other factors should be taken into account. For details, contact the authorised service centre or professionals.

Repairing paint surfaces

Always check whether there are any paint peeled off or scratches on the vehicle body surface. If such a phenomenon occurs, repair the surface immediately to prevent corrosion of the metal in the damaged area.

Repair paint can only be used to repair small areas of peeled-off paint or scratches. Large areas of peeled-off paint should be repaired by professionals.

Liquid leakage check

To ensure driving safety, it is recommended to check for fuel, oil or other liquid leaks under the vehicle before each driving. In case of the apparent leakage, contact the authorised service centre for service.

Interior maintenance

⚠ WARNING

Cleaning agents may contain harmful substances that could cause injuries. For cleaning the interior, it is recommended to open the vehicle doors or raise the windows. Use only cleaning agents that are made for vehicle cleaning and follow the instructions on the package.

ℹ NOTICE

- › Do not allow water or any liquid to run directly into to the instrument panel, the floor or nearby electrical components when cleaning the interior, as water may enter and cause malfunction.
- › Do not clean the vehicle floor with water in order to avoid vehicle body corrosion.

Carpets

Regularly clean carpets with a vacuum cleaner. Allowing dirt to remain on carpets will increase wear on them.

Regularly washing carpets with detergent will keep them in better condition. Use a foaming detergent to clean carpets. To keep carpets as dry as possible, do not add water to the foaming detergent.

Vehicle maintenance

Textile

Regularly use a vacuum cleaner to remove dirt from the textile.

For general cleaning, use a clean, soft cloth moistened with mild warm soapy water. To avoid water marks after drying, wipe with another clean and soft damp cloth, and then dry in the air.

Use a textile cleaner to remove stubborn stains. Follow the instructions for using the cleaner.

Leather

Regularly use a vacuum cleaner to remove dirt, especially from creases and seams.

Clean the leather with a soft cloth dampened with water, and then buff it up with another soft dry cloth. Use a leather cleaner for deeper cleaning.

Wipe off the leather cleaner with a soft dry cloth as soon as possible after cleaning with the leather cleaner. Do not leave a cloth with leather cleaner on any part of the interior trim for a long time. Some leather cleaners may cause the resin or fibres of the interior trim textile to discolour or break.

Do not use liquid containing organic substances like alcohol to clean leather; do not use petrol, acidic solution or alkaline solution to clean leather.

Do not use brushes, hard sponges and other tools with rough surfaces when cleaning.

Rubber parts

Exposure to the environment may cause the surface of rubber parts to become soiled and lose their shine. Rubber parts should be cleaned regularly with rubber conditioners, especially worn rubber parts.

In order to avoid damage and to reduce noise, do not use conditioners that contain silicone for routine maintenance of rubber seals. Use only water or a suitable conditioner to clean.

Plastic parts

i NOTICE

Liquids containing alcohol or solvents (such as nitro thinner, cooling cleaner, fuel, perfume and cosmetics) can damage the surface of plastic parts. Clean with a soft microfibre cloth (slightly moistened with water).

Plastic parts include but are not limited to the following: artificial leather surface, roof lining, vehicle light glass shade, outlet assembly and inside painted parts.

Window

Clean the inside and outside of windows with glass cleaner and dry all glass and plastic surfaces with a soft cloth or paper towel.

Vehicle maintenance

⚠ CAUTION

If a heating wire is attached to the inside of the rear window, excessive wiping may cause it to move or break. Therefore, wipe lightly along the direction of the heating wire.

Seat belts

- › Use mild warm soapy water to clean soiled seat belts. Do not use bleach, dyes or cleaning solvents. Such products may reduce the durability of seat belts.
Allow the seat belt to dry naturally in the air before driving.
- › Too much dust accumulated inside the seat belt guide ring will cause the seat belt to retract more slowly. Scrub the inner side of the guide ring with mild warm soapy water.

Anti-corrosion measures

Factors that affect the corrosion rate

- › The accumulation of dirt, dust, or snow in the lower part of the vehicle body can accelerate corrosion.
- › Damage to the coating or other protective layer, arising from sand attacking or minor accident, may quicken corrosion.
- › If the vehicle runs in areas where relative humidity is high or temperature is above freezing point, it may quicken corrosion.

- › There is much salinity in the air and salt on the road of industrial pollution areas and coastal regions, which may quicken the paint corrosion.
- › Rising temperature may quicken the corrosion of poorly ventilated parts.

Protecting the vehicle from corrosion

- › Park the vehicle in a well-ventilated and dry place.
- › Regularly use clean cold water and neutral vehicle detergent to wash the vehicle so as to keep it clean.
- › Regularly check whether the paint is damaged. If damaged, repair it as soon as possible.
- › Regularly check the lower part of the vehicle body. If there is sand, dirt, snow, ice or other coverings, clean them with water as soon as possible.
- › Check the interior of the vehicle frequently to ensure that the carpet is dry and clean.

When transporting chemicals, cleaning agents, fertilizers, salt, etc., take special care and use appropriate containers for transportation. If splashes or leaks are found, clean them immediately and keep them dry.

- › Keep the door drain hole open so as to avoid water logging.

Vehicle maintenance

- › If bird droppings, resin, insect carcasses, asphalt, cement, industrial dust, coal tar, gasoline, benzene or other similar objects are accumulated on the body surface, clean them as soon as possible.
- › If you always drive on a deicing salt covered road, saline-alkali land, seaside and other roads containing salt, please wash off the attachments at the bottom of the vehicle at least once a month, and take special maintenance measures, such as chassis armour.
- › If you drive regularly on sand road, please consider installing mudguard behind the wheels.
- › Open vehicle windows on one side slightly (if the vehicle is to be parked indoors).
- › Disconnect the negative terminal of the battery.
- › Use a stowed towel or piece of cloth to cushion the wiper blade from the windscreen glass.
- › To reduce the risk of sticking, silicone lubricant should be applied on all door seals.
- › Use a vehicle cover made of porous cotton to cover the vehicle. Because plastic materials such as non-porous materials will accumulate moisture, and is likely to damage the vehicle body paint.
- › When possible, run the engine for short periods from time to time until it reaches operating temperature.

Long-term storage of the vehicle

The parking position of the vehicle should help to prevent deterioration of the vehicle condition and facilitate the restarting of the vehicle. If possible, please park your vehicle indoor.

If you need to store the vehicle for an extended period (one month or longer), please take the following steps beforehand:

- › Top up fuel.
- › Clean and dry vehicle exterior thoroughly.
- › Clean the inside of the vehicle to ensure it is clean and tidy.
- › Release the parking brake, and use the wheel chock to hold against the tyres.





7

Technical data

Vehicle identification.....278

Overall parameters280

Vehicle identification

Vehicle equipment

Please note that this manual contains all the standard equipment, country-specific equipment and special equipment for this model series. Thus, some equipment or features described in this manual may not be installed onto your vehicle or are only available in some markets. For further configuration information, please refer to relevant sales information or consult with your distributor selling the vehicle to you.

Vehicle identification number

The vehicle identification number (VIN) is the identity code of the vehicle and unique to every vehicle. It is marked in the following locations:

- › The upper left side of the instrument panel;

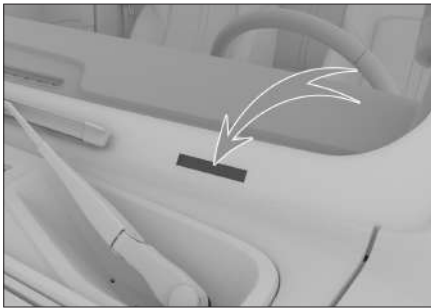

- › The vehicle nameplate;
- Vehicle nameplate located under the

central pillar door hinge

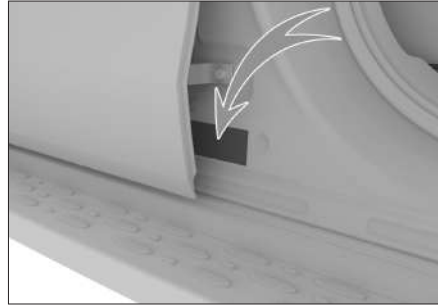

Vehicle nameplate located under the central pillar lock catch



i NOTICE

Due to different countries and regions, some models may only have one nameplate fitted. Refer to the actual vehicle.

Vehicle identification

- › Front section of the right longitudinal beam of the frame.

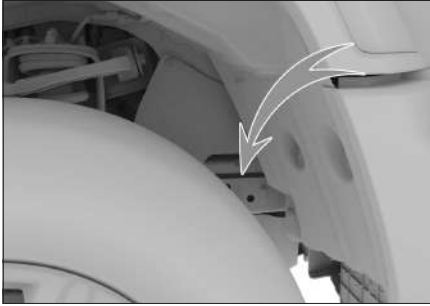

77E19ABC9995

i NOTICE

Due to different countries and regions, some models have the vehicle identification number marked on the front section of the left longitudinal beam of the frame. Refer to the actual vehicle.

i NOTICE

After using the diagnostic tool to connect the on-board diagnosis connector, you can read the vehicle identification number in the electronic control unit (ECU).

Engine number

E20CB

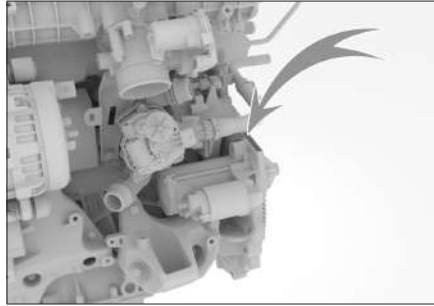

D020F4A00CD1

The engine number is engraved on the cylinder block above the starter as shown in the figure.

i NOTICE

For ease of viewing, a label containing the engine model and number is attached to the cylinder head cover near the exhaust side.

Overall parameters

Basic parameters

For basic parameters such as the overall dimensions, quality, fuel consumption, emission standard, maximum speed, see the official vehicle documents attached to the vehicle.

⚠ CAUTION

Unless specifically stated or separately listed parameters, all the parameters listed in this manual are applicable to the standard vehicles. For specially equipped vehicles and those vehicles produced for other countries, some of the parameters may be different. Parameters in the official vehicle documents attached to the vehicle shall always prevail.

Power parameters

Engine

Model	Type	Maximum net power/speed [KW/rpm]	Maximum net torque/speed [N•m / rpm]	Maximum gradeability [%]
E20CB	Turbocharged gasoline engine	162/5500	380/1800-3600	50

Tyre specifications

Items		Data
Specifications	Standard tyre	265/65R17 112H, 265/65R17 116H, 265/60 R18 110H
	Spare tyre	
Tyre pressure		See the tyre pressure label on the lower part of the left front door pillar.
Tyre chain	Specifications	Tyre chain of model T150 TPU
	Installation location	Rear wheels

Wheel parameters

Items		Data
Dynamic balance parameters	Unilateral [g]	≤8
	Bilateral sum [g]	≤15

Overall parameters

Items			Data
Alignment parameters	Rear wheel	Rear wheel camber	$0^{\circ}\pm 30'$ (left and right difference $\leq 30'$)
		Rear wheel toe-in	$0^{\circ}\pm 30'$ (left and right difference $\leq 30'$)
	Front wheel	Kingpin backwards inclination	$4^{\circ}\pm 30'$ (left and right difference $\leq 30'$)
		Front-wheel camber	$11'\pm 30'$ (left and right difference $\leq 30'$)
		Front wheel toe-in	$5'\pm 5'$ (left and right difference $\leq 2'$)
		Kingpin inwards inclination	$12.3^{\circ}\pm 30'$ (left and right difference $\leq 30'$)

Braking parameters

Items		Data
Brake pedal	Free travel [mm]	10.3 ± 1
Front brake pad (friction material)	Minimum thickness [mm]	2
Rear brake pad (friction material)	Minimum thickness [mm]	2
Front brake disk	Minimum thickness [mm]	29
Rear brake disk	Minimum thickness [mm]	20

Seat parameters

Items		Data
Design position of seat sliding rail		Move 40 mm forward from the last position.
Design angle of seat backrest	Front seat	22°
	Rear seat	25°
Common angle of seat backrest	Front seat	$22^{\circ}\sim 25^{\circ}$
	Rear seat	25° or 29°

Overall parameters

Oil parameters

Engine oil

Specifications of E20CB engine oil

If you choose API (American Petroleum Institute) standard oils, we recommend to use fully synthetic oil:

Items	Data	
Ambient temperature	-30°C or higher	Lower temperature
Quality grade	SN	SN
Viscosity grade	5W-30	0W-30

If you choose an oil product in conformity with the ACEA (European Automobile Manufacturers' Association) standard, our suggestions are as follows:

- › Use the C2 5W-30 fully synthetic oil when the temperature in your region is above -30°C.
- › When your local temperature is less than the above value, please use the C2 0W-30 fully synthetic oil.

Engine oil capacity

Engine model	Capacity [L] (reference value)	
	When changing both the oil and the oil filter	When only changing the oil
E20CB	5.5±0.1	5.0±0.1

Other types of oil

Oil type	Specifications	Capacity [L] (reference value)
Front main decelerator oil	DUAL 9 FE 75W-90	1.05±0.05
Rear main decelerator oil	DUAL 9 FE 75W-90	2.4±0.1
Transfer case oil	Dexron III	1.5±0.05

Overall parameters

Oil type	Specifications	Capacity [L] (reference value)
Coolant (engine system)	Ethylene glycol-based - No. 35 (regions other than alpine region) Ethylene glycol-based - No. 45 (alpine regions)	7.9±0.5
Brake fluid	DOT4 synthetic brake fluid	0.95±0.1
Windscreen washer fluid	--	2.0±0.1

i NOTICE

The above oil capacity is the design value. The actual amount may slightly vary with the products, equipment and climate factors.

8

Index

Alphabetical index..... 286

Alphabetical index

A

A/C system 62

Airbag

 Curtain airbag 218

 Far-end side airbag 220

 Side airbag 218

Airbags

 Front airbags 215

All-terrain control system 115,117

Anti-lock brake system 169

B

Battery 258

Bottle holder 76

Brake fluid 257

Braking force assist system 170

Break-in period 99

C

Catalytic converter 173

Child restraint system

 Fixing points for child seat 222

 Recommended child seat type 223

Child safety lock 29

Crankcase emission control unit 174

D

Differential lock 121

Door lock

 Locking and unlocking with central control buttons 25

 Locking and unlocking with key buttons 25

 Locking during emergencies 26

 Unlocking with the interior handle 25

Door locks

 Locking and unlocking through the

 PEPS 24

 Locking and unlocking with the mechanical key 25

Dynamic stability assist system 172

E

Electronic braking force distribution system 170

Electronic parking brake 105

Electronic Power Steering System 171

Electronic stability control 171

Emergency braking warning 55

Engine compartment 253

Engine coolant 256

Engine oil 255

Engine overheating 244

Event data recorder 229

Exterior maintenance 270

F

Fluid level 254

Fuel shutoff system 228

Fuses 261

G

Gasoline particulate filter 175

H

Headrest 40

HHC (Hill-start hold control) 170

Hill descent control system 168

Hood 37

Horn 47

I

Indicator lights 182

Alphabetical index

Instrument brightness adjustment 56

Instrument panel

Virtual instrument panel 177

Intelligent start/stop system 125

Interior maintenance 272

Interior rearview mirror

Automatic anti-glare interior rearview mirror 45

Manual anti-glare interior rearview mirror 45

J

Jump start method 242

K

Key 20

L

Light control

Center roof lamp 57

Daytime running lights 55

Hazard warning lights 56

Leaving light 55

Light control combination switch 51

Light height adjustment 56

Reading lamp 56

Lights control

Front fog lights auxiliary lighting 55

M

Mobile wireless charging 70

O

Oil parameters 282

On-board diagnostic system 174

Oxygen sensor 173

P

Parking assist system

Anti-collision radar 130

Around view monitor (AVM) 131

Sensor 128

Power management system 191

Power parameters 280

Power steering mode 114

Power supply socket 79

Power supply switch 101

R

Radiator and fan 258

Refuelling 38

Replacing the spare tyre 237

Rollover prevention system 170

Roof rack 49

S

Seat

Adjustment of front seat 41

Rear armrest 44

Seat belt 211

Seat parameters 281

Seats

Front seat ventilation/heating 41

Rear seat adjustment 42

Secondary collision mitigation system 170

Side mirrors 45

Spare tyre 234

Spectacle case 73

Starting and shutting down the engine 103

Steering wheel 47

Sunroof

Opening and closing the sunroof 34

Alphabetical index

Opening and closing the visor 35
Sunroof maintenance 269
Sun visor 72

T

Tyre pressure monitoring system 136
Tailgate
 Emergency unlock 28
 Manual tailgate 27
Towing 246
Traction control system 170
Turbocharger 174
Tyre maintenance 267

V

Vanity mirror 72
Vehicle anti-theft system 226
Vehicle identification number 278

W

Warning lights 182
Windows 31
Windscreen washer fluid 257
Wiper control
 Auto wiper 58

